

RS-SM 650R/2016

Ed. 06-2015



RS 650R



SM 650R



Catalogo ricambi
Spare parts catalog
Catalogue pieces de rechange
Ersatzteilkatalog
Catalogo piezas de repuestos

INFORMAZIONI GENERALI

Il presente catalogo serve per richiedere con esattezza le parti di ricambio
Nelle ordinazioni indicare:

- 1) il numero di codice dei particolari seguito dalla descrizione;
- 2) il colore per i pezzi verniciati o comunque colorati;
- 3) il numero di matricola del motociclo, stampigliato sul canotto di sterzo.

Le indicazioni destra e sinistra si riferiscono ai lati del veicolo rispetto al senso di marcia;

Dati indicativi soggetti a modifiche senza impegno di preavviso.

All data are subject to modification without prior notice.

Données indicatif sujet au modifications sans obligation de préavis.

Anderungen vorbehalten.

Datos indicativos sujetos a modificaciones sin compromiso de preaviso.

GENERAL INFORMATION

The present spare parts list enables one to order exactly the right spare parts.

When ordering specify:

- 1) the part's code number followed by its description;
- 2) indicate colour for painted or coloured parts;
- 3) the motorcycle's serial number, stamped on the steering head.

References to right and left apply to the vehicle in terms of its direction of movement.

NOTE - LIST - NOTES - NOTE - NOTAS:

AUS : Australia, Australia, Australie, Australien, Australia

CDN : Canada, Canada, Canada, Kanada, Canadá

IT : Italia, Italy, Italie, Italien, Italia

JAP : Giappone, Japan, Japon, Japan, Japón

USA : Stati Uniti d'America, United States of America, Etats Units d'Amerique, Vereinigte Staaten von Amerika, Estados Unidos

N° DI MATRICOLA INIZIALE - INITIAL SERIAL NUMBER - MATRICULE INITIAL - BEGINNTESERIENNUMMER - MATRICULA INICIAL	
MODELLO - MODEL MODELE - MODELL MODELO	MATRICOLA - SERIAL NUMBER MATRICULE - SERIENNUMMER MATRICULA
RS 650R	ZN0A400AABV000001
SM 650R	ZN0A400ABBV000001

INFORMATIONS GENERALES

Ca catalogue permet de commander correctement les pièces de rechange.

Les commandes doivent être passées en indiquant:

- 1) le numéro de code des pièces détachées suivi de leur description;
- 2) le couleur des pièces peintes ou colorés;
- 3) le matricule de la moto, estampillé sur la tige du guidon.

Droite et gauche sont les côtés du véhicule par rapport au sens de la marche.

ALLGEMEINE HINWEISE

Dieser Ersatzteilkatalog dient zur genauen Angabe der Teile bei Ersatzteilbestellungen.

Bei Ersatzbestellung ist folgendes anzugeben:

- 1) Die Bestellnummer der Ersatzteile mit der entsprechenden Beschreibung;
- 2) Farbe für lackierte und farbige Teile angeben;
- 3) Die Sseriennummer des Motorrads, die am Lenkrohr eingepägt ist.

Die Angaben rechts und links beziehen sich auf das Fahrzeug in Fahrriichtung.

INFORMACIONES GENERALES

El presente catálogo sirve para pedir con exactitud las partes de recambio.

En los pedidos se debe indicar:

- 1) el número de código de la parte y a continuación la descripción;
- 2) el color para las piezas barnizadas o coloreadas;
- 3) el número de matrícula de la motocicleta, estampado en le tubo de dirección.

Las indicaciones derecha e izquierda se refieren a los lados del vehículo respecto del sentido de marcha.



INDICE – INDEX – INDEX – INHALTSVERZEICHNIS - INDICE

RS-SM 650R/2016

Tavola Drawing Table Bild Tabla	Denominazione	Description	Designation	Bezeichnung	Denominacion	Pagina Page Page Seite Paja
1	ATTREZZI DI ASSISTENZA, MANUALI E CATALOGHI	SERVICE TOOLS, MANUALS AND CATALOGS	OUTILS D'ASSISTANCE, MANUELS ET CATALOGUES	HILFAUSRUSTUNG, HANDBUCH UND KATALOG	HERRAMIENTAS DE ASISTENCIA, MANUALES Y CATALOGOS	13
2	CILINDRO, PISTONE	CYLINDER, PISTON	CYLINDRE, PISTON	ZYLINDER, KOLBEN	CILINDRO, PISTON	15
3	TESTA CILINDRO	CYLINDER HEAD	CULASSE	ZYLINDERKOPF	CULATA	17
4	MANOVELLISMO	CRANKSHAFT	VILEBREQUIN	KURBELWELLE	CIGÜEÑAL	23
5	TRASMISSIONE PRIMARIA, FRIZIONE	PRIMARY DRIVE, CLUTCH	TRANSMISSION PRIMAIRE, EMBRAYAGE	PRIMÄRÜBERSETZUNG, KUPPLUNG	TRANSMISION PRIMARIA, EMBRAGUE	25
6	DISTRIBUZIONE	VALVE TIMING	DISTRIBUTION	VENTILSTEUERUNG	DISTRIBUCION	29
7	SEMICARTER SINISTRO	L.H. HALF CRANKCASE	CARTER G.	GEHAUSEDECKEL L.	BANCADA IZQ.	31
8	SEMICARTER DESTRO	R.H. HALF CRANKCASE	CARTER D.	GEHAUSEDECKEL R.	BANCADA DER.	33
9	COPERCHI BASAMENTO	CRANKCASE COVERS	COUVERCLES CARTER	GEHAUSEDECKEL	TAPAS BANCADA	35
10	COMANDO CAMBIO	GEARSHIFT MECHANISM	COMMANDE DE VITESSE	GANGSCHALTUNG	MANDO CAMBIO	37
11	LUBRIFICAZIONE	OIL PUMP	PUMPE HUILE	MOTORSCHMIERUNG	LUBRICACION	39
12	PARTE ELETTRICA, IMPIANTO ELETTRICO	IGNITION SYSTEM, ELECTRIC SYSTEM	PARTIES ELECTRIQUE, INSTALLATION ELECTRIQUE	ELEKTRISCHE TEILE, ELEKTRISHE ANLAGE	PARTE ELECTRICA, INSTALLACION ELECTRICA	43
13	CORPO FARFALLATO	THROTTLE BODY	CORP PAPILLON	DROSSELKLAPPENKÖRPER	CUERPO OSCILANTE	45
14	FILTRO ARIA	AIR FILTER	FILTRE AIRE	LUFTFILTER	FILTRO DE AIRE	47
15	IMPIANTO DI RAFFREDAMENTO	COOLING SYSTEM	INSTALLATION RAFROIDISSEMENT	SCHMIERUNGSSYSTEM	EQUIPO DE ENFRIAMIENTO	49
16	TELAIO, PEDANE	FRAME, FOOT RESTS	CADRE, REPOSE PIEDS	RAHMEN, FUSSBRETT	BASTIDOR, REPOSAPIES	53
17	SOSPENSIONE ANTERIORE	FRONT FORK ASSEMBLY	SUSPENSION AVANT	VORDETELESKOPGABEL	SUSPENSION DELANTERA	57
18	FORCELLONE POSTERIORE	REAR SWING ARM	FOURCHE ARRIERE	HINTERGABEL	HORQUILLA TRASERA	61
19	LEVRAGGI SOSPENSIONI POSTERIORE	REAR SUSPENSION LINKAGE	LEVIER SUSPENSION ARRIERE	HEBELWERK HINTERHAUFHANGUNG	PALANCA SUSPENSION TRASERA	65
20	AMMORTIZZATORE POSTERIORE	REAR SUSPENSION	SUSPENSION ARRIERE	HINTERHAUFHANGUNG	SUSPENSION TRASERA	67
21	MANUBRIO E COMANDI	HANDLEBAR AND CONTROLS	GUIDON ET COMMANDES	LENKER UND STEUERORGANE	MANILLAR Y MANDOS	69
22	PANNELLI, PARAFANGHI, SELLA	PANEL, FENDERS, SEAT,	PANNEAU, GARDE-BOUES, SIEGE,	STREIFEN, KOTFLUGEL, SATTEL	PANELO, GUARDABARROS, SILLIN	71
23	SERBATOIO CARBURANTE, CONVOGLIATORI	GAS TANK, PANEL	RESERVOIR CARBURANT, FLANC	KRAFTSTOFFBEHALTER, FLANKE	DEPOSITO GASOLINA, LATERAL	75
24	SCARICO	EXHAUST SYSTEM	TUYAU D'ECHAPPEMENT	AUSPUFFROHR	TUBO DE ESCAPE	79
25	FRENO IDRAULICO ANTERIORE (RS)	FRONT HYDRAULIC BRAKE (RS)	FREIN HYDRAULIQUE AVANT (RS)	VORDERBREMSE (RS)	FRENO HIDRAULICO DELANTERO (RS)	81
25A	FRENO IDRAULICO ANTERIORE (SM)	FRONT HYDRAULIC BRAKE (SM)	FREIN HYDRAULIQUE AVANT (SM)	VORDERBREMSE (SM)	FRENO HIDRAULICO DELANTERO (SM)	83
26	FRENO IDRAULICO POSTERIORE	REAR HYDRAULIC BRAKE	FREIN HYDRAULIQUE ARRIERE	HINTERBREMSE	FRENO HIDRAULICO TRASERO	85
27	RUOTA ANTERIORE (SM)	FRONT WHEEL (SM)	ROUE AVANT (SM)	VORTERRAD (SM)	RUEDA DELANTERA (SM)	87
27A	RUOTA ANTERIORE (RS)	FRONT WHEEL (RS)	ROUE AVANT (RS)	VORTERRAD (RS)	RUEDA DELANTERA (RS)	89
28	RUOTA POSTERIORE	REAR WHEEL	ROUE ARRIERE	HINTERRAD	RUEDA TRASERA	91



Tavola - Drawing - Table - Bild - Tabla

1

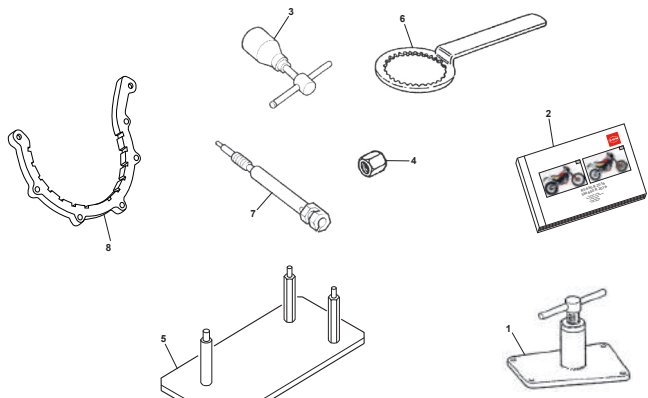

Pagina - Page - Page - Seite - Paja

12

Tavola - Drawing - Table - Bild - Tabla

2

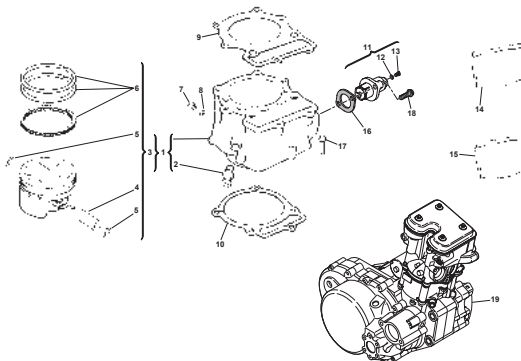

Pagina - Page - Page - Seite - Paja

14

Tavola - Drawing - Table - Bild - Tabla

3

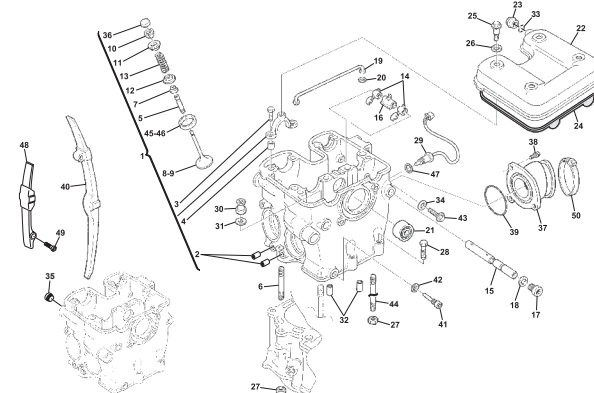

Pagina - Page - Page - Seite - Paja

16

Tavola - Drawing - Table - Bild - Tabla

4

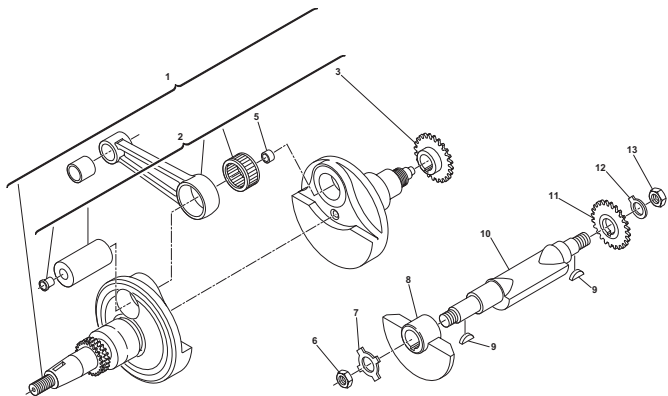

Pagina - Page - Page - Seite - Paja

22

Tavola - Drawing - Table - Bild - Tabla

5

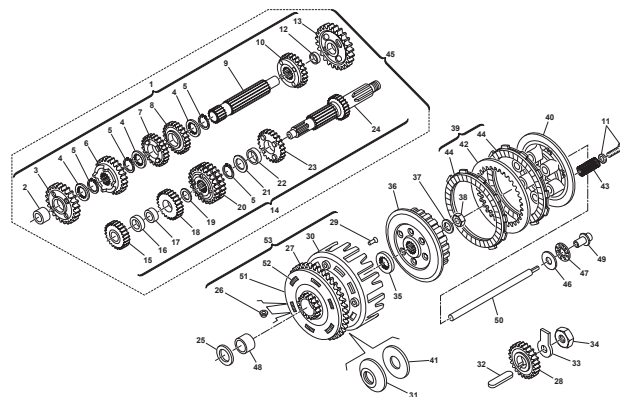

Pagina - Page - Page - Seite - Paja

24

Tavola - Drawing - Table - Bild - Tabla

6

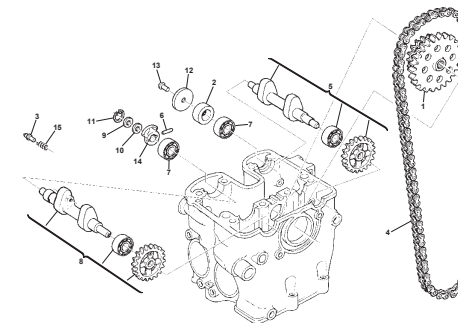

Pagina - Page - Page - Seite - Paja

28

Tavola - Drawing - Table - Bild - Tabla

7

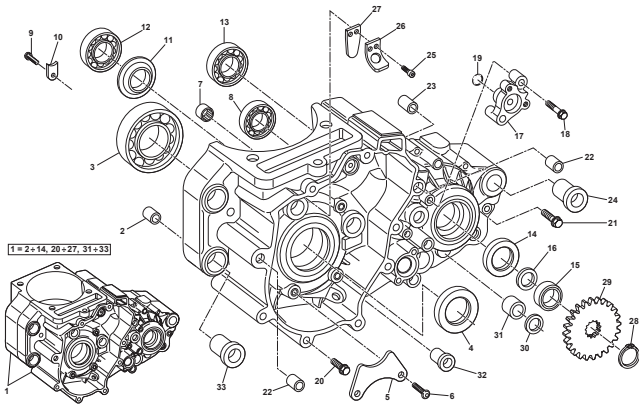

Pagina - Page - Page - Seite - Paja

30

Tavola - Drawing - Table - Bild - Tabla

8

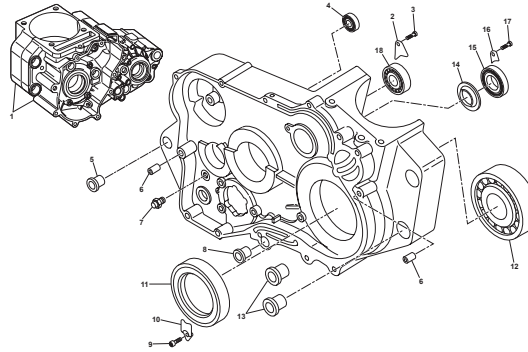

Pagina - Page - Page - Seite - Paja

32

Tavola - Drawing - Table - Bild - Tabla

9

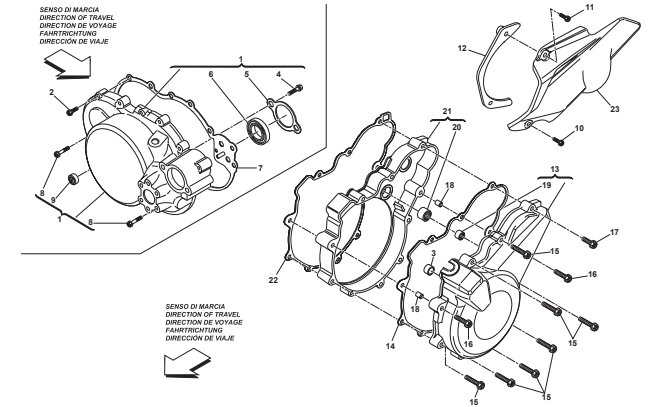

Pagina - Page - Page - Seite - Paja

34

Tavola - Drawing - Table - Bild - Tabla

10

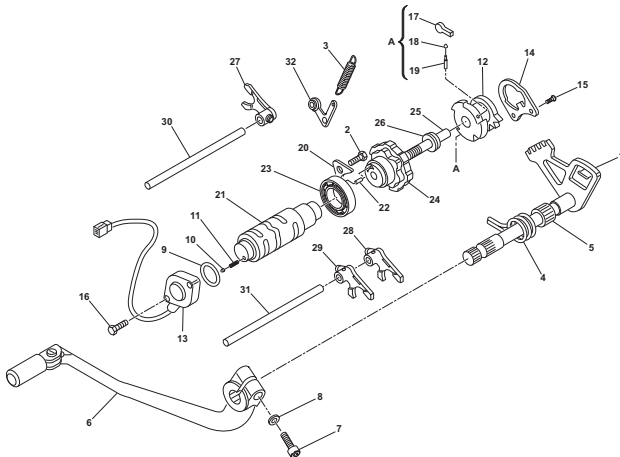

Pagina - Page - Page - Seite - Paja

36

Tavola - Drawing - Table - Bild - Tabla

11

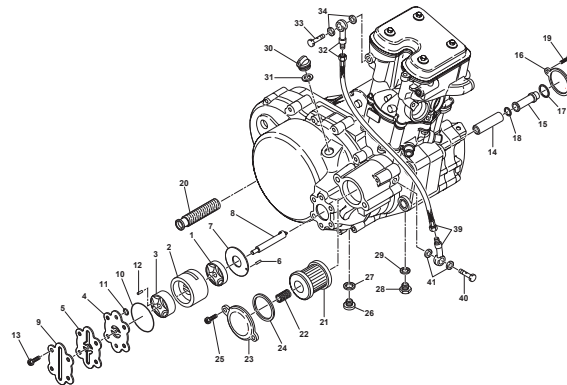

Pagina - Page - Page - Seite - Paja

38

Tavola - Drawing - Table - Bild - Tabla

12

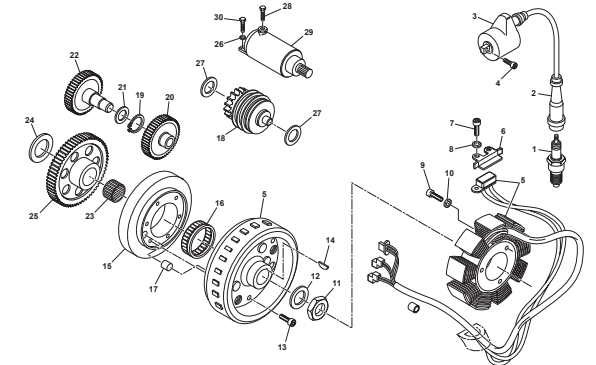

Pagina - Page - Page - Seite - Paja

42



Tavola - Drawing - Table - Bild - Tabla

13

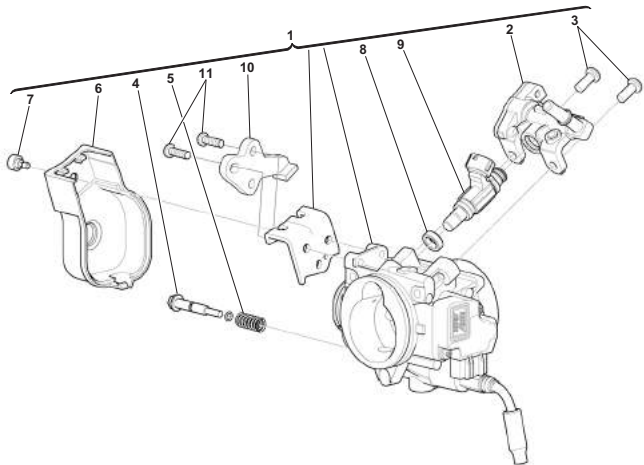

Pagina - Page - Page - Seite - Paja

44

Tavola - Drawing - Table - Bild - Tabla

14

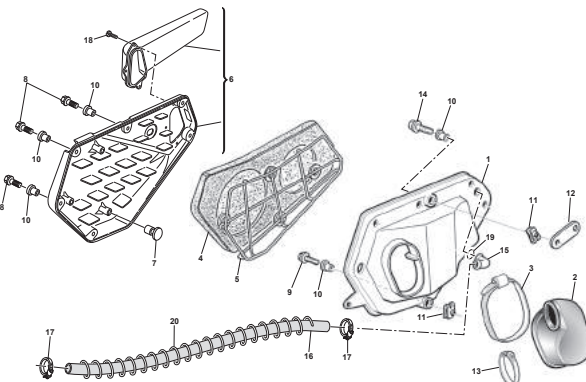

Pagina - Page - Page - Seite - Paja

46

Tavola - Drawing - Table - Bild - Tabla

15

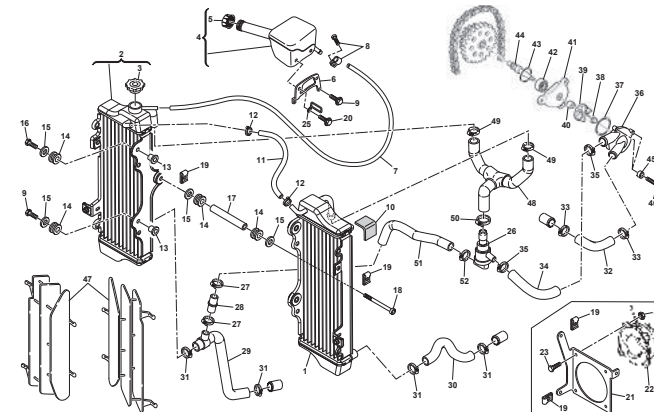

Pagina - Page - Page - Seite - Paja

48

Tavola - Drawing - Table - Bild - Tabla

16

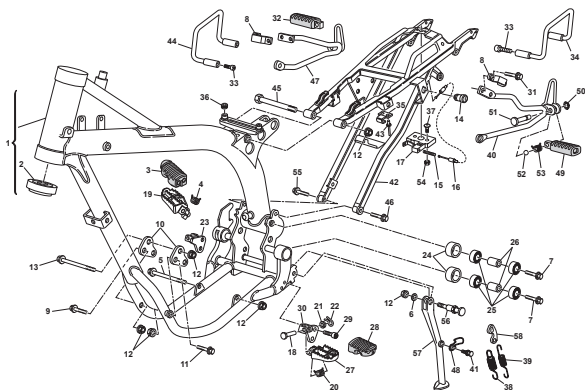

Pagina - Page - Page - Seite - Paja

52

Tavola - Drawing - Table - Bild - Tabla

17

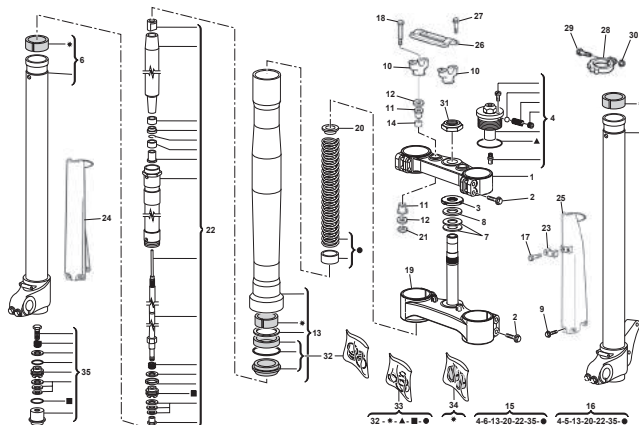

Pagina - Page - Page - Seite - Paja

56

Tavola - Drawing - Table - Bild - Tabla

18

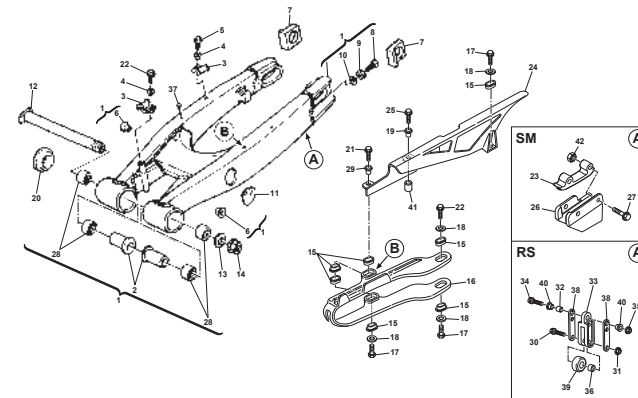

Pagina - Page - Page - Seite - Paja

60

Tavola - Drawing - Table - Bild - Tabla

19

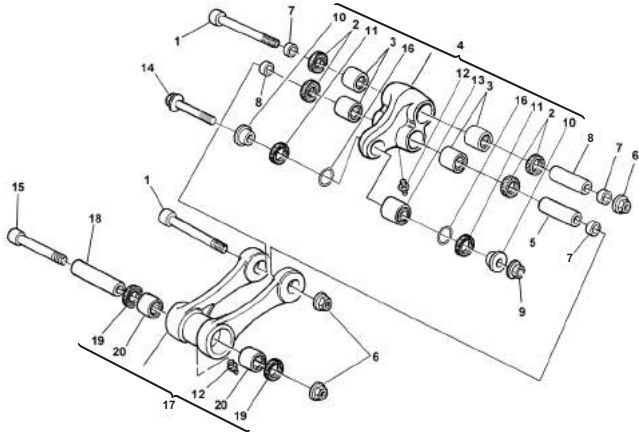

Pagina - Page - Page - Seite - Paja

64

Tavola - Drawing - Table - Bild - Tabla

20

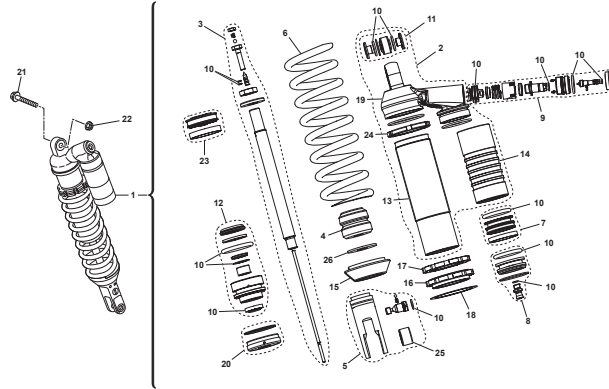

Pagina - Page - Page - Seite - Paja

66

Tavola - Drawing - Table - Bild - Tabla

21

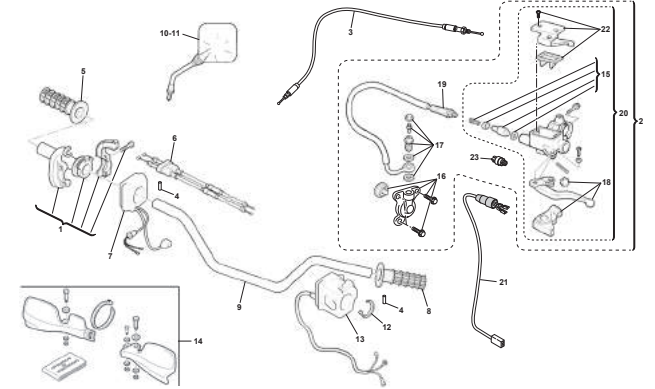

Pagina - Page - Page - Seite - Paja

68

Tavola - Drawing - Table - Bild - Tabla

22

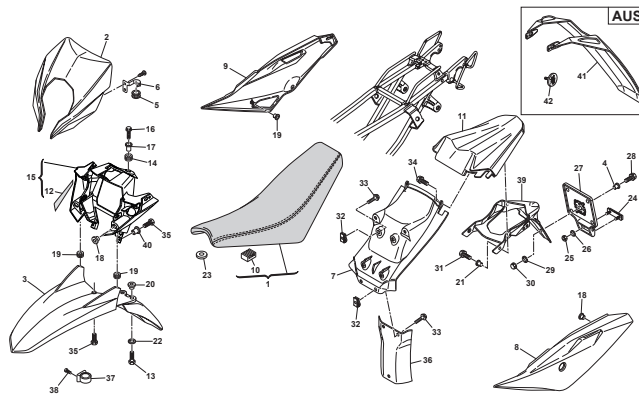

Pagina - Page - Page - Seite - Paja

70

Tavola - Drawing - Table - Bild - Tabla

23

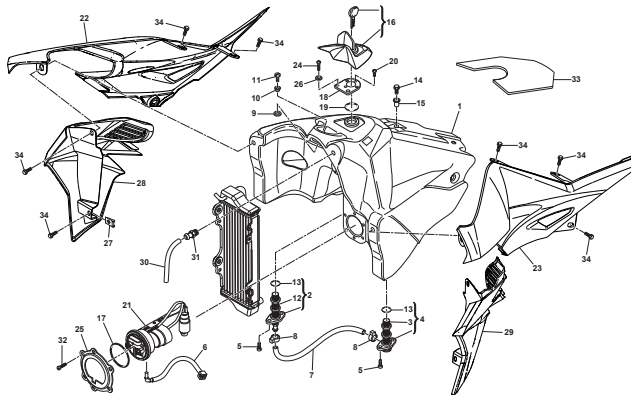

Pagina - Page - Page - Seite - Paja

74

Tavola - Drawing - Table - Bild - Tabla

24

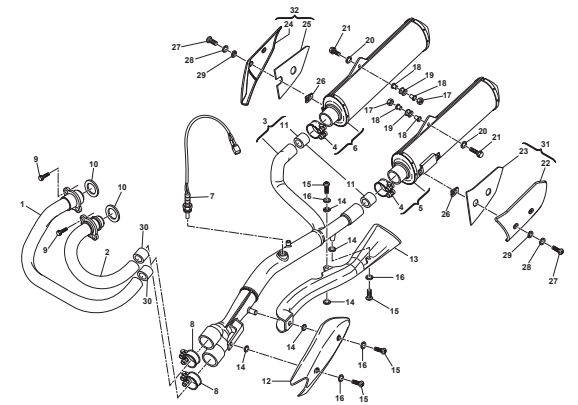

Pagina - Page - Page - Seite - Paja

78



Tavola - Drawing - Table - Bild - Tabla

25

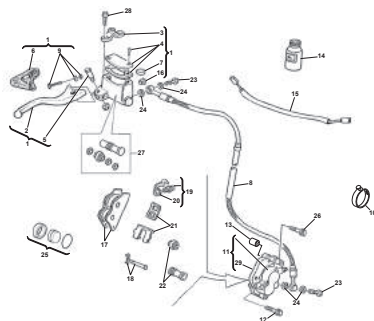

Pagina - Page - Page - Seite - Paja

80

Tavola - Drawing - Table - Bild - Tabla

25A

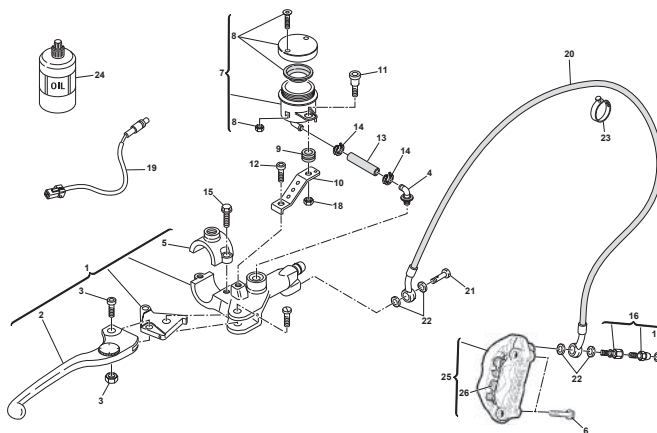

Pagina - Page - Page - Seite - Paja

82

Tavola - Drawing - Table - Bild - Tabla

26

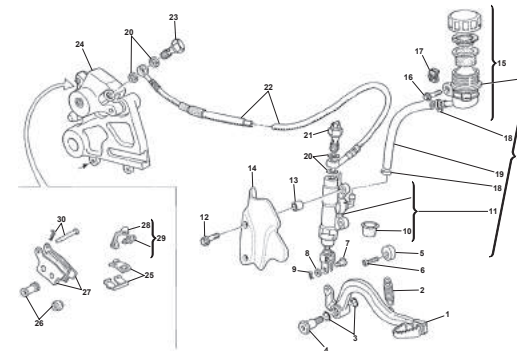

Pagina - Page - Page - Seite - Paja

84

Tavola - Drawing - Table - Bild - Tabla

27

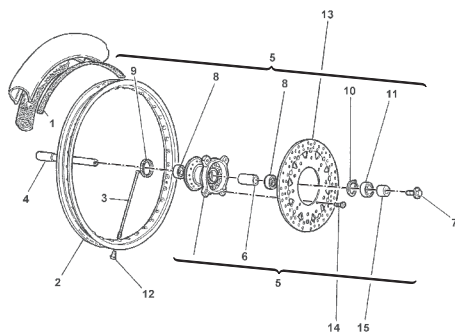

Pagina - Page - Page - Seite - Paja

86

Tavola - Drawing - Table - Bild - Tabla

27A

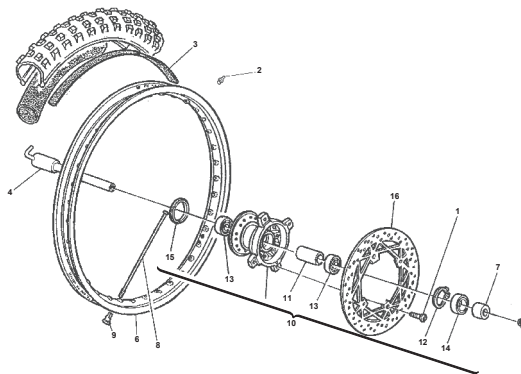

Pagina - Page - Page - Seite - Paja

88

Tavola - Drawing - Table - Bild - Tabla

28

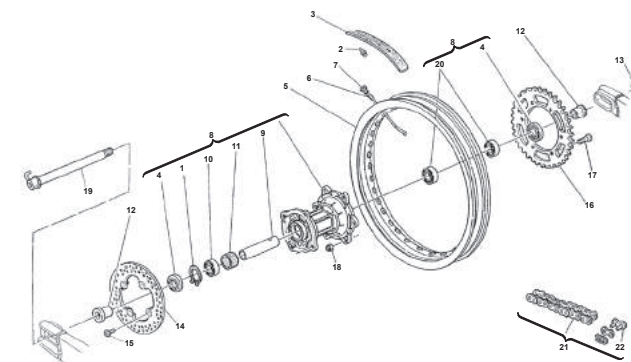

Pagina - Page - Page - Seite - Paja

90

Tavola - Drawing - Table - Bild - Tabla

29

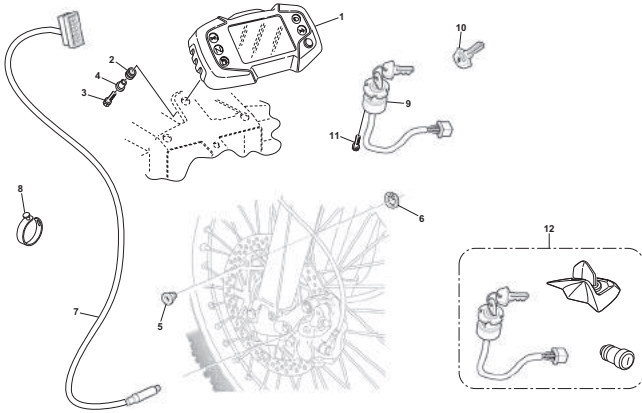

Pagina - Page - Page - Seite - Paja

92

Tavola - Drawing - Table - Bild - Tabla

30

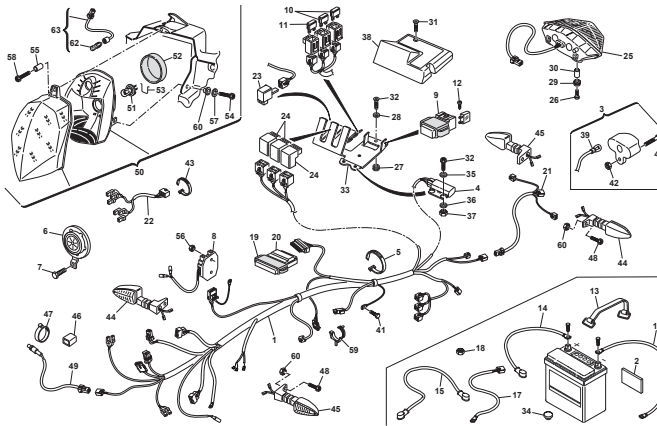

Pagina - Page - Page - Seite - Paja

94

Tavola - Drawing - Table - Bild - Tabla

31

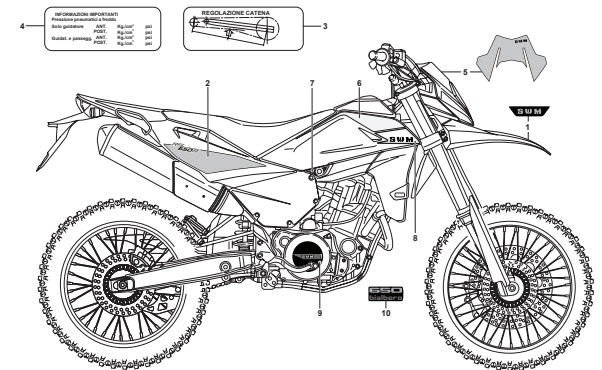

Pagina - Page - Page - Seite - Paja

98

Tavola - Drawing - Table - Bild - Tabla

31A

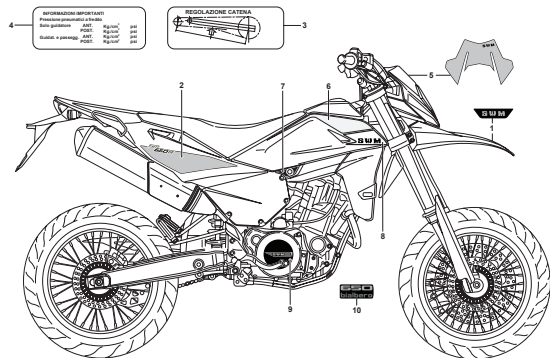

Pagina - Page - Page - Seite - Paja

100

Tavola - Drawing - Table - Bild - Tabla



Pagina - Page - Page - Seite - Paja

Tavola - Drawing - Table - Bild - Tabla



Pagina - Page - Page - Seite - Paja





**PAGINA INTENZIONALMENTE BIANCA
INTENTIONALLY WHITE PAGE**

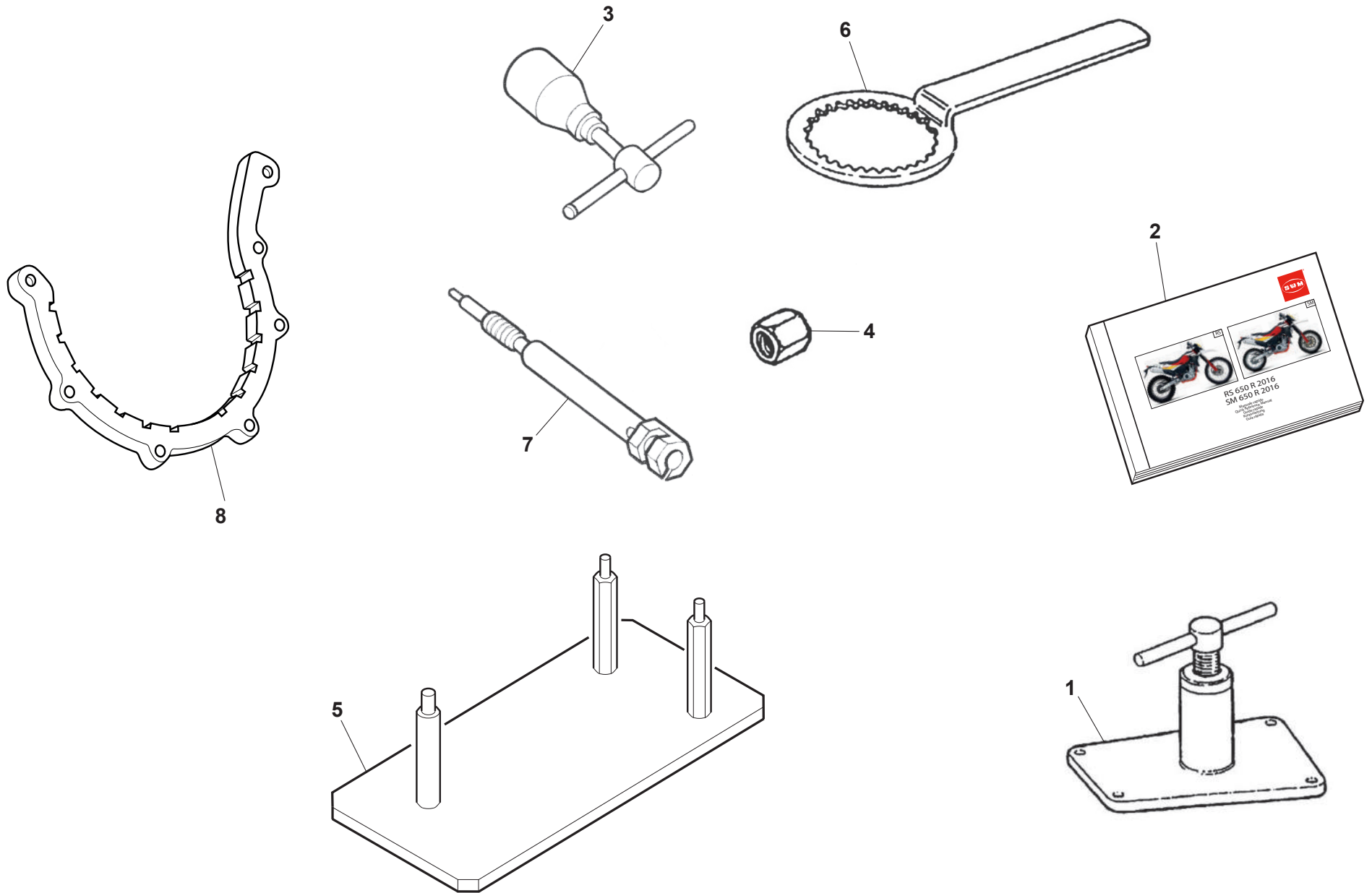

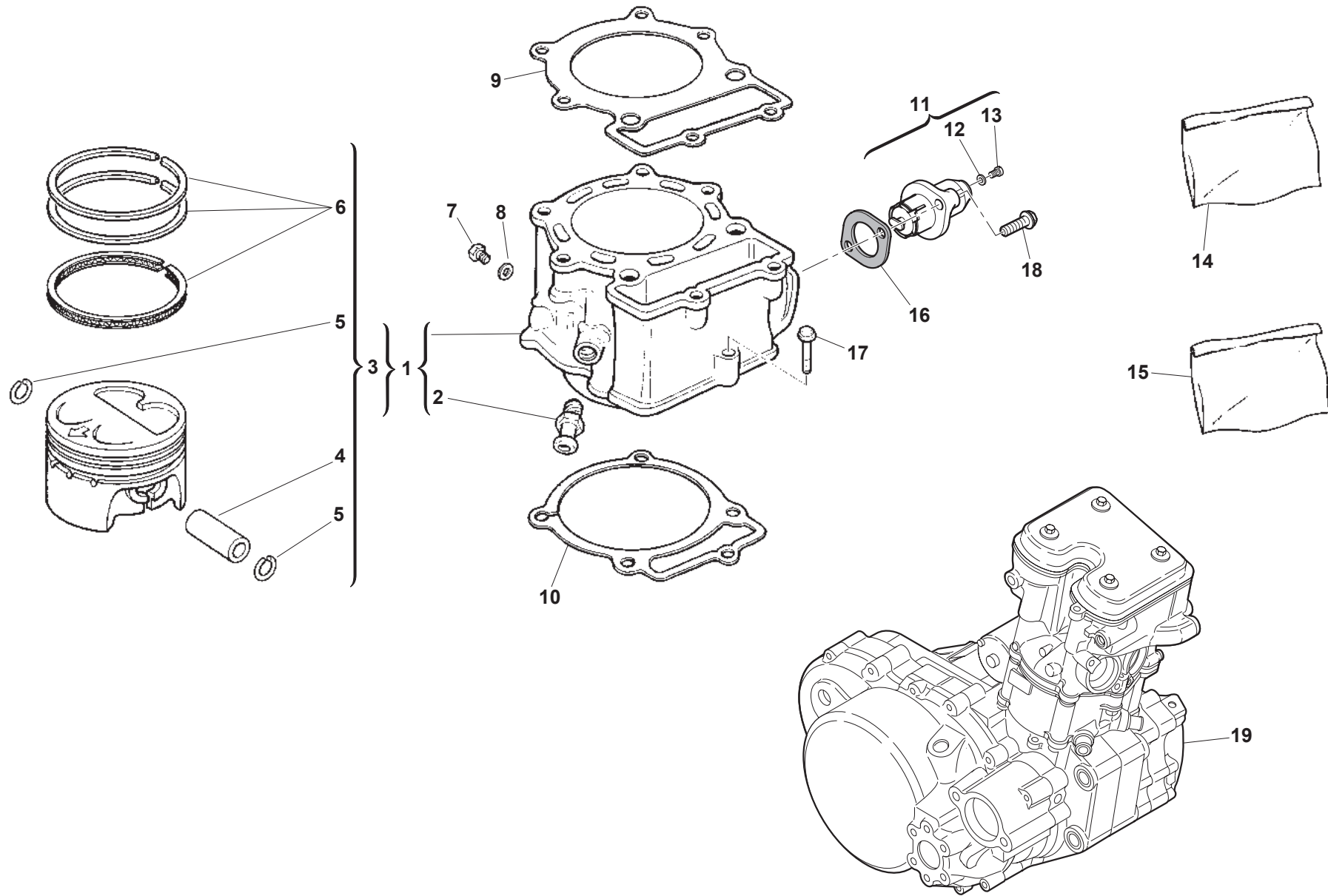

**RS-SM 650R/2016**
**CILINDRO, PISTONE - CYLINDER, PISTON
 CYLINDRE, PISTON- ZYLINDER, KOLBEN
 CILINDRO, PISTON**

 TAVOLA
 DRAWING
 TABLE
 BILD
 TABLA
2

Note Notes Notes Marke Notas	Pos. No. N. Index Pos.	N. Cod. Code No. Nr. Code Code Nr N. Cod.	Q.tà Q.ty Q.te M.ge C.ad	DENOMINAZIONE	NAME	DESIGNATION	BESHREIBUNG	DENOMINACION
	1	M000A00100	1	CILINDRO COMPLETO	CYLINDER ASSY	CYLINDRE COMPLET	ZYLINDER KOMPL	CILINDRO COMPLETO
	2	800063885	2	RACCORDO	JOINT	RACCORD	ANSCHLUSS	EMPALME
	3	8000H6251	1	PISTONE COMPLETO	PISTON ASSY	PISTON COMPLET	KOLBEN KOMPLETT	PISTON COMPLETO
	4	8000A9652	1	SPINOTTO PISTONE	PIN, PISTON	AXE PISTON	KOLBENBOLZEN	BULON PISTON
	5	8000A5475	2	ANELLINO FERMA SPINOTTO	CLIP PISTON PIN	ATTACHE AXE PISTON	SICHERUNG, KOLBENBOLZEN	GRAPA, BULON PISTON
	6	8000H6252	1	SERIE SEGMENTI	PISTON RING SET	JEU SEGMENT PISTON	KOLBENRING SATZ	JUEGO ARO PISTON
	7	ZS0067545	1	VITE TEF M6X1X8 CH8	SCREW TEF M6X1X8 CH8	VIS TEF M6X1X8 CH8	SCHRAUBE TEF M6X1X8 CH8	TORNILLO TEF M6X1X8 CH8
	8	8A0015960	1	GUARNIZIONE 10X6,2X1	GASKET 10X6,2X1	JOINT 10X6,2X1	DICHTUNG 10X6,2X1	JUNTA 10X6,2X1
	9	8A00H0937	1	GUARNIZIONE TESTA CILINDRO 1,1 MM	GASKET CYLINDER HEAD 1.1 MM	JOINT CULASSE 1,1 MM	DICHTUNG ZYLINDERKOPF 1,1 MM	JUNTA CULATA 1,1 MM
	9	8B00H0937	1	GUARNIZIONE TESTA CILINDRO 1,0 MM	GASKET CYLINDER HEAD 1.0 MM	JOINT CULASSE 1,0 MM	DICHTUNG ZYLINDERKOPF 1,0 MM	JUNTA CULATA 1,0 MM
	9	8000H0937	1	GUARNIZIONE TESTA CILINDRO 1,2 MM	GASKET CYLINDER HEAD 1.2 MM	JOINT CULASSE 1,2 MM	DICHTUNG ZYLINDERKOPF 1,2 MM	JUNTA CULATA 1,2 MM
	10	800099841	1	GUARNIZIONE BASE CILINDRO	GASKET, CYLINDER BASE	JOINT BASE CYLINDRE	DICHTUNG, ZYLINDER	JUNTA BASE CILINDRO
	11	8000A6950	1	TENDICATENA DISTRIBUZIONE	TENSIONER, TIMING CHAIN	TENDEUR CHAINE DISTRIBUTION	STEUERKETTENSANNER	TENSIONADOR CADENA DISTRIBUCION
	12	8000A6358	1	RONDELLA	WASHER	RONDELLE	SCHEIBE	ARANDELA
	13	8000A6357	1	VITE TEF M6X8	SCREW TEF M6X8	VIS TEF M6X8	SCHRAUBE TEF M6X8	TORNILLO TEF M6X8
	14	8000H1760	1	SERIE GUARNIZIONI MOTORE	GASKET SET, ENGINE	JEU JOINT MOTEUR	MOTORDICHTUNGSSATZ	JUEGO JUNTAS MOTOR
	15	8000H1761	1	SERIE PARAOLIO MOTORE	OIL SEAL SET, ENGINE	JEU BAGUES ETANCHEITE MOTEUR	MOTORWELLENDICHTRINGENSATZ	JUEGO RETENES ACEITE MOTOR
	16	8000A6954	1	GUARNIZIONE TENDICATENA DISTRIBUZIONE	GASKET, TENSIONER ADJUSTER	JOINT TENDEUR CHAINE DISTRIBUTION	DICHTUNG STEUERKETTENSANNER	JUNTA TENSIONADOR CADENA DISTRIBUCION
	17	Z00062730	2	VITE TE M6X1X30 CH8	SCREW TE M6X1X30 CH8	VIS TE M6X1X30 CH8	SCHRAUBE TE M6X1X30 CH8	TORNILLO TE M6X1X30 CH8
	18	Z00062728	2	VITE TEF M6X1X20 CH8	SCREW TEF M6X1X20 CH8	VIS TEF M6X1X20 CH8	SCHRAUBE TEF M6X1X20 CH8	TORNILLO TEF M6X1X20 CH8
	19	M000A00030	1	MOTORE	ENGINE	MOTEUR	MOTOR	MOTOR

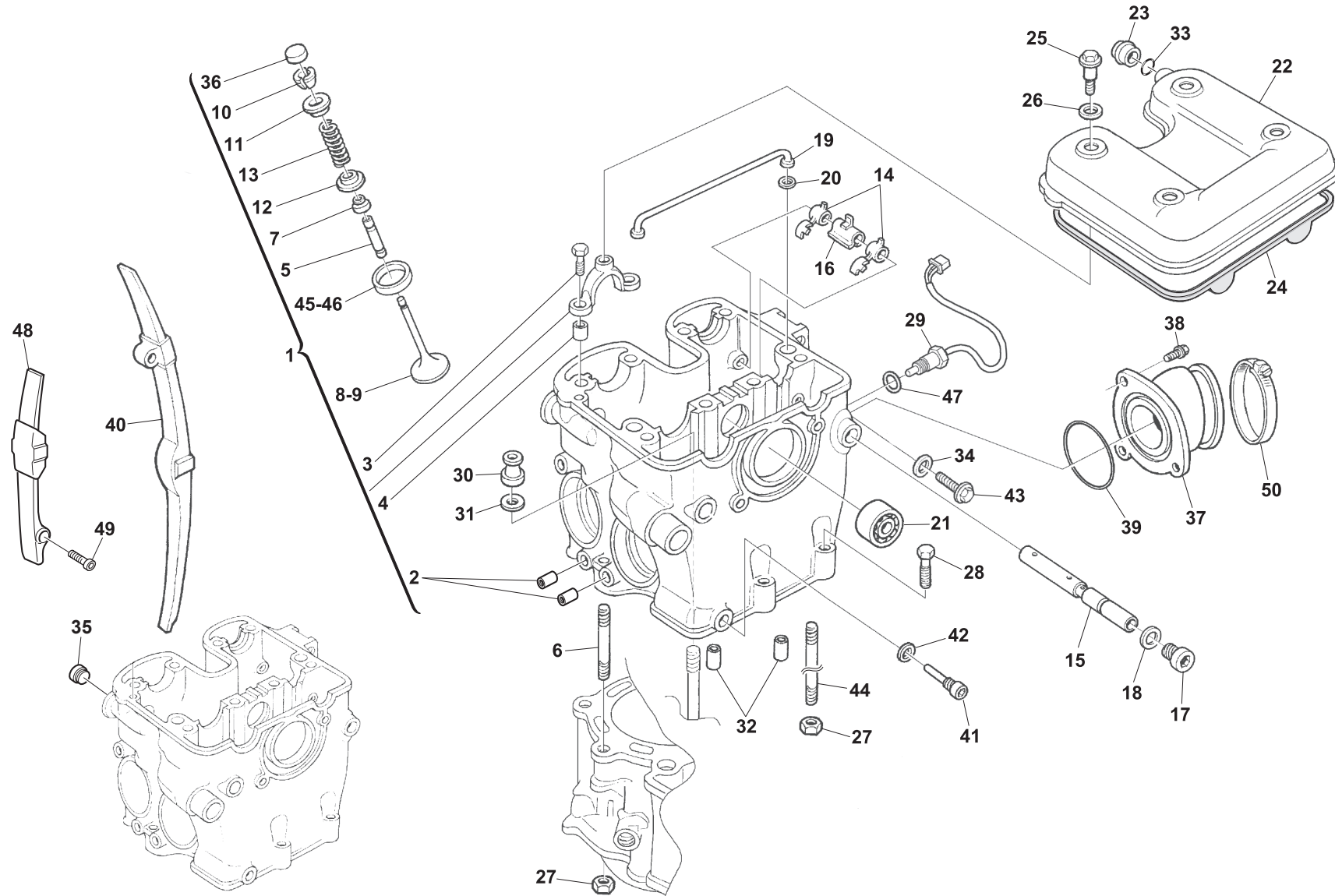

**RS-SM 650R/2016**
**TESTA CILINDRO - CYLINDER HEAD
 CULASSE - ZYLINDERKOPF
 CULATA**

 TAVOLA
 DRAWING
 TABLE
 BILD
 TABLA
3

Note Notes Notas	Pos. No. N. Index Pos.	N. Cod. Code No. Nr. Code Code Nr N. Cod.	Q.tà Q.ty M.ge C.ad	DENOMINAZIONE	NAME	DESIGNATION	BESHREIBUNG	DENOMINACION
	1	M000A00096	1	TESTA CILINDRO	HEAD, CYLINDER	CULASSE	ZYLINDERKOPF	CULATA
	2	800049792	4	INSERTO FILETTATO HELI-COIL	THREADED INSERT HELI-COIL	INSERTION FILETE HELI-COIL	GEWINDINSATZ HELI-COIL	ROSCA ROSCADA HELI-COIL
	3	8A0085071	8	VITE TCEI M6X1X25	SCREW TCEI M6X1X25	VIS TCEI M6X1X25	SCHRAUBE TCEI M6X1X25	TORNILLO TCEI M6X1X25
	4	161795501	8	BOCCOLA 8X6,4X6	BUSH 8X6.4X6	DOUILLE 8X6,4X6	BUCHSE 8X6,4X6	CASQUILLO 8X6,4X6
	5	8000A4158	2	GUIDAVALVOLA SCARICO 5 MM	GUIDE, EXHAUST VALVE 5 MM	GUIDE-SOUPAPE ECHAPPEMENT 5 MM	AUSLASSVENTILFUEHRUNG 5 MM	GUIA-VALVULA ESCAPE 5 MM
	5	8000A4159	2	GUIDAVALVOLA ASPIRAZIONE 5,5 MM	GUIDE INTAKE VALVE 5.5 MM	GUIDE-SOUPAPE D'ASPIRATION 5,5 MM	EINLASSVENTILFUEHRUNG 5,5 MM	GUIA-VALVULA ADMISION 5,5 MM
	6	800074836	2	PRIGIONIERO CILINDRO M8X51MM	STUD BOLT M8X51MM	GOUJON M8X51MM	STIFTSCHRAUBE M8X51MM	ESPARRAGO M8X51MM
	7	8000A4136	2	PARAOLIO VALVOLA 5 MM	SEAL VALVE STEM 5 MM	BAGUE D'ETENCHEITE SOUPAPE 5 MM	WELLENDICHTRING VENTIL 5 MM	RETEN DE ACEITE VALVULA 5 MM
	7	8000A4137	2	PARAOLIO VALVOLA 5,5 MM	SEAL VALVE STEM 5.5 MM	BAGUE D'ETENCHEITE SOUPAPE 5,5 MM	WELLENDICHTRING VENTIL 5,5 MM	RETEN DE ACEITE VALVULA 5,5 MM
	8	8000H4195	2	VALVOLA ASPIRAZIONE	VALVE, INTAKE	SOUPAPE ADMISSION	EINLASSVENTIL	VALVULA ADMISION
	9	8000H4194	2	VALVOLA SCARICO ACCIAIO	VALVE, EXHAUST STEEL	SOUPAPE D'ECHAPPEMENT ACIER	VENTIL, AUSLASS STHAL	VALVULA DE ESCAPE ACERO
	10	8000A4106	4	SEMICONO VALVOLA 5 MM	COTTER, VALVE 5 MM	DEMI-CLAVETTE SOUPAPE 5 MM	VENTILHALBKEGEL 5 MM	SEMICONO VALVULA 5 MM
	10	8000A4107	4	SEMICONO VALVOLA 5,5 MM	COTTER, VALVE 5.5 MM	DEMI-CLAVETTE SOUPAPE 5,5 MM	VENTILHALBKEGEL 5,5 MM	SEMICONO VALVULA 5,5 MM
	11	8000A4151	2	SCODELLINO MOLLA VALVOLA SCARICO 5 MM	RETAINER, EXHAUST VALVE SPRING 5 MM	FIXATION RESSORT SUPAPE ECHAPPEM. 5 MM	TELLER, AUSLASSVENTILFEDER 5 MM	RETEN, RESORTE VALVULA DESCARGA 5 MM
	11	8000A4157	2	SCODELLINO MOLLA VALVOLAASPIRAZ. 5,5 MM	RETAINER, SPRING INTAKE VALVE 5.5 MM	FIXATION RESSORT SUPAPE ASPIRATION 5,5MM	TELLER, EINLASSVENTILFEDER 5,5 MM	RETEN, RESORTE VALVULAADMISION 5,5 MM
	12	800091578	2	SEDE MOLLA VALVOLA SCARICO	SEAT, SPRING EXHAUST	SIEGE RESSORT DU SOUPAPE ECHAPPEMENT	SITZ, AUSLASSVENTILFEDER	ASIENTO MUELLE VALVULA ESCAPE
	12	8000A4135	2	SEDE MOLLA VALVOLA ASPIRAZIONE	SEAT, SPRING INTAKE	SIEGE RESSORT DU SOUPAPE ADMISSION	SITZ, ENLASS VENTILFEDER	ASIENTO MUELLE VALVULA ADMISION
	13	8000A0568	4	MOLLA VALVOLA	SPRING, VALVE	RESSORT SOUPAPE	VENTILFEDER	MUELLE PARA VALVULA
	14	800091568	4	BILANCIERE	ARM ROCKER	CULBUTEUR	KIPPEBEL	BALANCIN
	15	8000A5437	2	ASSE BILANCIERE	AXLE, VALVE ROCKER ARM	AXE CULBUTEURS	KIPPEBELACHSE	EJE BALANCIN
	16	8B00A5435	1	DISTANZIALE A MOLLA 25,8MM	SPACER, SPRING 25.8MM	ENTRETOISE 25,8MM	ABSTANDHALTER 25,8MM	DISTANCIADOR 25,8MM
	16	8C00A5435	1	DISTANZIALE A MOLLA 30,8MM	SPACER, SPRING 30.8MM	ENTRETOISE 30,8MM	ABSTANDHALTER 30,8MM	DISTANCIADOR 30,8MM
	17	800099711	2	TAPPO DIN 908 M14X1,5	PLUG DIN 908 M14X1.5	BOUCHON DIN 908 M14X1,5	VERSCHLUSS DIN 908 M14X1,5	TAPON DIN 908 M14X1,5
	18	800047763	2	RONDELLA 17,9X14,2X1,5 MM	WASHER 17.9X14.2X1.5 MM	RONDELLE 17,9X14,2X1,5 MM	SCHEIBE 17,9X14,2X1,5 MM	ARANDELA 17,9X14,2X1,5 MM
	19	800099834	1	TUBO OLIO	HOSE, OIL	TUYAU HUILE	OELSCHLAUCH	MANGUERA ACEITE
	20	800091584	2	ANELLO O-RING 2018 1,78 D4,48	O-RING 2018 1.78 D4.48	JOINT TORIQUE 2018 1,78 D4,48	O-RING 2018 1,78 D4,48	JUNTA TORICA 2018 1,78 D4,48
	21	800034317	1	CUSCINETTO A SFERE 12X28X8	BEARING, BALL 12X28X8	ROULEMENT A BILLES 12X28X8	KUGELLAGER 12X28X8	COJINETE DE BOLAS 12X28X8
	22	M000P00098	1	COPERCHIO VALVOLE	COVER, CYLINDER HEAD	COUVERCLE CULASSE	DECKEL, ZYLINDERKOPF	CUBIERTA CULATA
	23	8000A7039	1	RACCORDO SFIATO	JOINT, BREATHER	RACCORD, RENIFLARD	ANSCHLUSS, BELUFTUNG	RACOR RESPIRADERO
	24	800099837	1	GUARNIZIONE COPERCHIO VALVOLE	GASKET CYLINDER HEAD COVER	JOINT, COUVERCLE CULASSE	DICHTUNG, ZYLINDERKOPFDECKEL	JUNTA CUBIERTA CULATA
	25	Z00091587	4	VITE	SCREW	VIS	SCHRAUBE	TORNILLO
	26	800091588	4	RONDELLA	WASHER	RONDELLE	SCHEIBE	ARANDELA
	27	Z00054700	2	DADO	NUT	ECROU	MUTTER	TUERCA

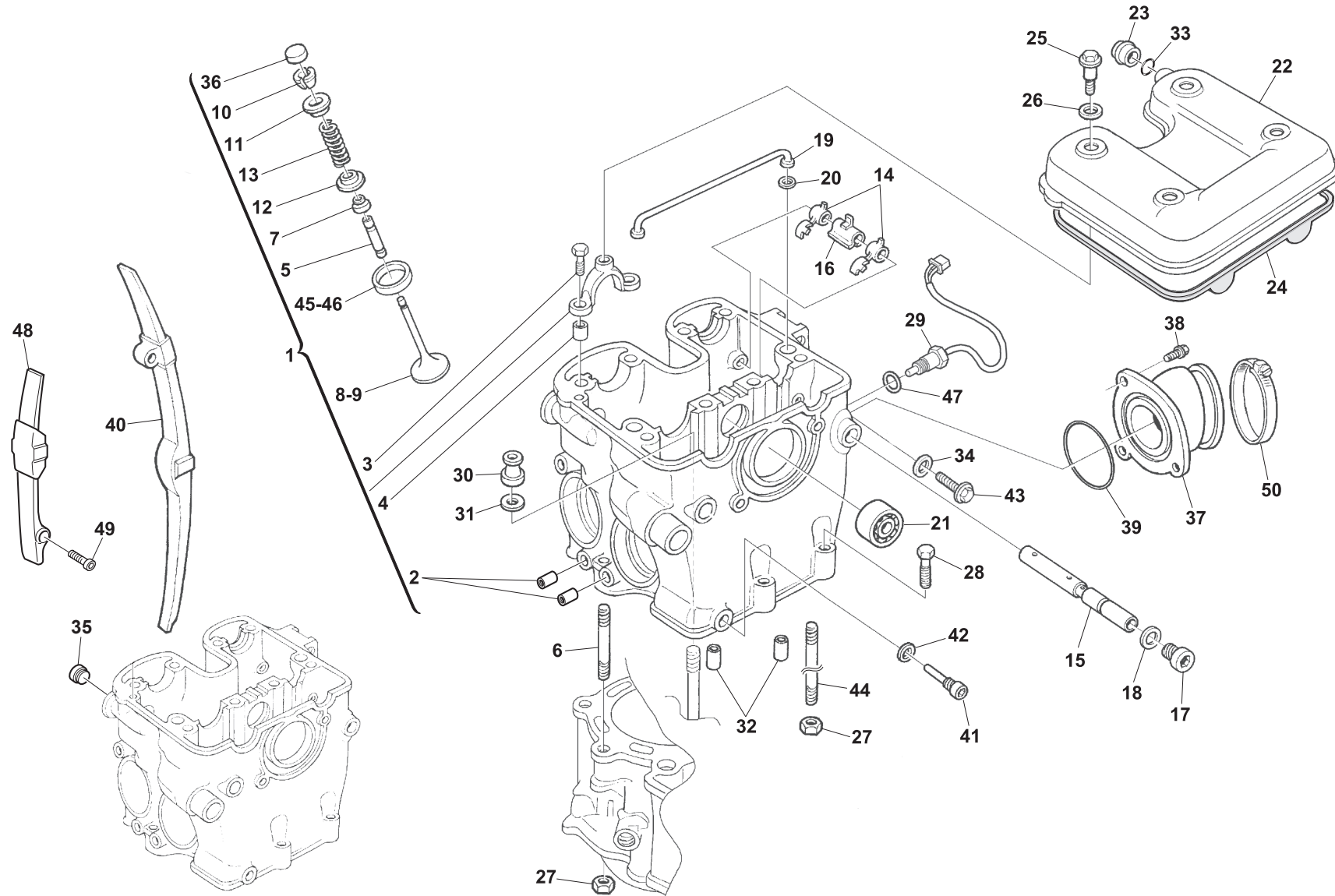

**RS-SM 650R/2016**
**TESTA CILINDRO - CYLINDER HEAD
 CULASSE - ZYLINDERKOPF
 CULATA**

 TAVOLA
 DRAWING
 TABLE
 BILD
 TABLA
3

Note Notes Notes Marke Notas	Pos. No. N. Index Pos.	N. Cod. Code No. Nr. Code Code Nr N. Cod.	Q.tà Q.ty Q.te M.ge C.ad	DENOMINAZIONE	NAME	DESIGNATION	BESHREIBUNG	DENOMINACION
	28	Z00062730	2	VITE TE M6X1X30 CH8	SCREW TE M6X1X30 CH8	VIS TE M6X1X30 CH8	SCHRAUBE TE M6X1X30 CH8	TORNILLO TE M6X1X30 CH8
	28	ZE0067545	1	VITE TEF M6X1X40 CH8	SCREW TEF M6X1X40 CH8	VIS TEF M6X1X40 CH8	SCHRAUBE TEF M6X1X40 CH8	TORNILLO TEF M6X1X40 CH8
	29	8000H3649	1	SENSORE TEMPERATURA ACQUA	SENSOR WATER TEMPERATURE	CAPTEUR TEMPERATURE EAU	WASSERTEMPERATURFUEHLER	SENSOR TEMPERATURA AGUA
	30	800091589	4	DADO	NUT	ECROU	MUTTER	TUERCA
	31	Z00023374	4	RONDELLA	WASHER	RONDELLE	SCHEIBE	ARANDELA
	32	8000H0278	4	BOCCOLA	BUSH	DOUILLE	BUCHSE	BUJE
	33	800001199	1	ANELLO O-RING	O-RING	JOINT TORIQUE	O-RING	JUNTA TORICA
	34	62N015672	1	RONDELLA ALLUMINIO 10X5,1X1 MM	ALUMINIUM WASHER 10X5,1X1 MM	RONDELLE EN ALUMINIUM 10X5,1X1 MM	ALUMINIUM SCHEIBE 10X5,1X1 MM	ARANDELA DE ALUMINIO 10X5,1X1 MM
	35	800057196	1	TAPPO 12X6X10	PLUG 12X6X10	BOUCHON 12X6X10	VERSCHLUSS 12X6X10	TAPON 12X6X10
	36	8P00A4162	4	PASTIGLIA VALVOLA 2,30 MM	PAD, VALVE ADJUSTING 2.30 MM	PASTILLE REGLAGE CULBETEUR 2,30 MM	VENTILKAEPFCHEN 2,30 MM	REGISTRO BALANCIN 2,30 MM
	36	8W00A4162	4	PASTIGLIA VALVOLA 2,60 MM	PAD, VALVE ADJUSTING 2.60 MM	PASTILLE REGLAGE CULBETEUR 2,60 MM	VENTILKAEPFCHEN 2,60 MM	REGISTRO BALANCIN 2,60 MM
	36	8V00A4162	4	PASTIGLIA VALVOLA 2,55 MM	PAD, VALVE ADJUSTING 2.55 MM	PASTILLE REGLAGE CULBETEUR 2,55 MM	VENTILKAEPFCHEN 2,55 MM	REGISTRO BALANCIN 2,55 MM
	36	8U00A4162	4	PASTIGLIA VALVOLA 2,50 MM	PAD, VALVE ADJUSTING 2.50 MM	PASTILLE REGLAGE CULBETEUR 2,50 MM	VENTILKAEPFCHEN 2,50 MM	REGISTRO BALANCIN 2,50 MM
	36	8T00A4162	4	PASTIGLIA VALVOLA 2,45 MM	PAD, VALVE ADJUSTING 2.45 MM	PASTILLE REGLAGE CULBETEUR 2,45 MM	VENTILKAEPFCHEN 2,45 MM	REGISTRO BALANCIN 2,45 MM
	36	8R00A4162	4	PASTIGLIA VALVOLA 2,35 MM	PAD, VALVE ADJUSTING 2.35 MM	PASTILLE REGLAGE CULBETEUR 2,35 MM	VENTILKAEPFCHEN 2,35 MM	REGISTRO BALANCIN 2,35 MM
	36	8N00A4162	4	PASTIGLIA VALVOLA 2,25 MM	PAD, VALVE ADJUSTING 2.25 MM	PASTILLE REGLAGE CULBETEUR 2,25 MM	VENTILKAEPFCHEN 2,25 MM	REGISTRO BALANCIN 2,25 MM
	36	8M00A4162	4	PASTIGLIA VALVOLA 2,20 MM	PAD, VALVE ADJUSTING 2.20 MM	PASTILLE REGLAGE CULBETEUR 2,20 MM	VENTILKAEPFCHEN 2,20 MM	REGISTRO BALANCIN 2,20 MM
	36	8L00A4162	4	PASTIGLIA VALVOLA 2,15 MM	PAD, VALVE ADJUSTING 2.15 MM	PASTILLE REGLAGE CULBETEUR 2,15 MM	VENTILKAEPFCHEN 2,15 MM	REGISTRO BALANCIN 2,15 MM
	36	8K00A4162	4	PASTIGLIA VALVOLA 2,10 MM	PAD, VALVE ADJUSTING 2.10 MM	PASTILLE REGLAGE CULBETEUR 2,10 MM	VENTILKAEPFCHEN 2,10 MM	REGISTRO BALANCIN 2,10 MM
	36	8H00A4162	4	PASTIGLIA VALVOLA 2,00 MM	PAD, VALVE ADJUSTING 2.00 MM	PASTILLE REGLAGE CULBETEUR 2,00 MM	VENTILKAEPFCHEN 2,00 MM	REGISTRO BALANCIN 2,00 MM
	36	8G00A4162	4	PASTIGLIA VALVOLA 1,95 MM	PAD, VALVE ADJUSTING 1.95 MM	PASTILLE REGLAGE CULBETEUR 1,95 MM	VENTILKAEPFCHEN 1,95 MM	REGISTRO BALANCIN 1,95 MM
	36	8F00A4162	4	PASTIGLIA VALVOLA 1,90 MM	PAD, VALVE ADJUSTING 1.90 MM	PASTILLE REGLAGE CULBETEUR 1,90 MM	VENTILKAEPFCHEN 1,90 MM	REGISTRO BALANCIN 1,90 MM
	36	8E00A4162	4	PASTIGLIA VALVOLA 1,85 MM	PAD, VALVE ADJUSTING 1.85 MM	PASTILLE REGLAGE CULBETEUR 1,85 MM	VENTILKAEPFCHEN 1,85 MM	REGISTRO BALANCIN 1,85 MM
	36	8D00A4162	4	PASTIGLIA VALVOLA 1,80 MM	PAD, VALVE ADJUSTING 1.80 MM	PASTILLE REGLAGE CULBETEUR 1,80 MM	VENTILKAEPFCHEN 1,80 MM	REGISTRO BALANCIN 1,80 MM
	36	8C00A4162	4	PASTIGLIA VALVOLA 1,75 MM	PAD, VALVE ADJUSTING 1.75 MM	PASTILLE REGLAGE CULBETEUR 1,75 MM	VENTILKAEPFCHEN 1,75 MM	REGISTRO BALANCIN 1,75 MM
	36	8B00A4162	4	PASTIGLIA VALVOLA 1,70 MM	PAD, VALVE ADJUSTING 1.70 MM	PASTILLE REGLAGE CULBETEUR 1,70 MM	VENTILKAEPFCHEN 1,70 MM	REGISTRO BALANCIN 1,70 MM
	36	8A00A4162	4	PASTIGLIA VALVOLA 1,65 MM	PAD, VALVE ADJUSTING 1.65 MM	PASTILLE REGLAGE CULBETEUR 1,65 MM	VENTILKAEPFCHEN 1,65 MM	REGISTRO BALANCIN 1,65 MM
	36	8000A4162	4	PASTIGLIA VALVOLA 1,60 MM	PAD, VALVE ADJUSTING 1.60 MM	PASTILLE REGLAGE CULBETEUR 1,60 MM	VENTILKAEPFCHEN 1,60 MM	REGISTRO BALANCIN 1,60 MM
	36	8S00A4162	4	PASTIGLIA VALVOLA 2,40 MM	PAD, VALVE ADJUSTING 2.40 MM	PASTILLE REGLAGE CULBETEUR 2,40 MM	VENTILKAEPFCHEN 2,40 MM	REGISTRO BALANCIN 2,40 MM
	36	8J00A4162	4	PASTIGLIA VALVOLA 2,05 MM	PAD, VALVE ADJUSTING 2.05 MM	PASTILLE REGLAGE CULBETEUR 2,05 MM	VENTILKAEPFCHEN 2,05 MM	REGISTRO BALANCIN 2,05 MM
	37	8000H0879	1	COLLETTORE ASPIRAZIONE	MANIFOLD, INTAKE	COLLECTEUR ADMISSION	EINSATZ KRUEMMER	COLECTOR ADMISION
	38	60ND02509	3	VITE TCEI M6X1X20 CH5	SCREW TCEI M6X1X20 CH5	VIS TCEI M6X1X20 CH5	SCHRAUBE TCEI M6X1X20 CH5	TORNILLO TCEI M6X1X20 CH5
	39	8A0028553	1	ANELLO O-RING 3200 2,62X50,47	O-RING 3200	JOINT TORIQUE 3200	O-RING 3200	JUNTA TORICA 3200

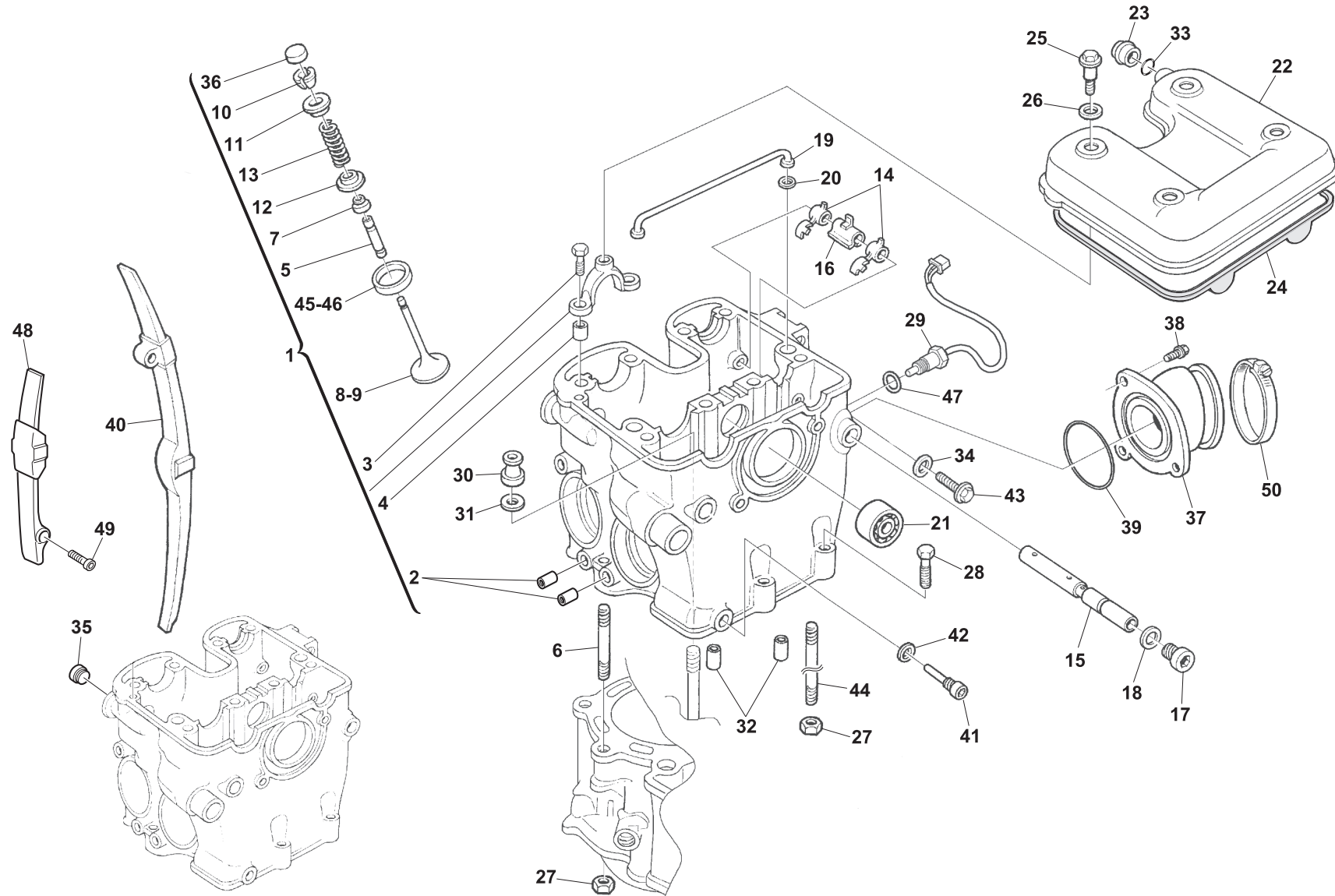

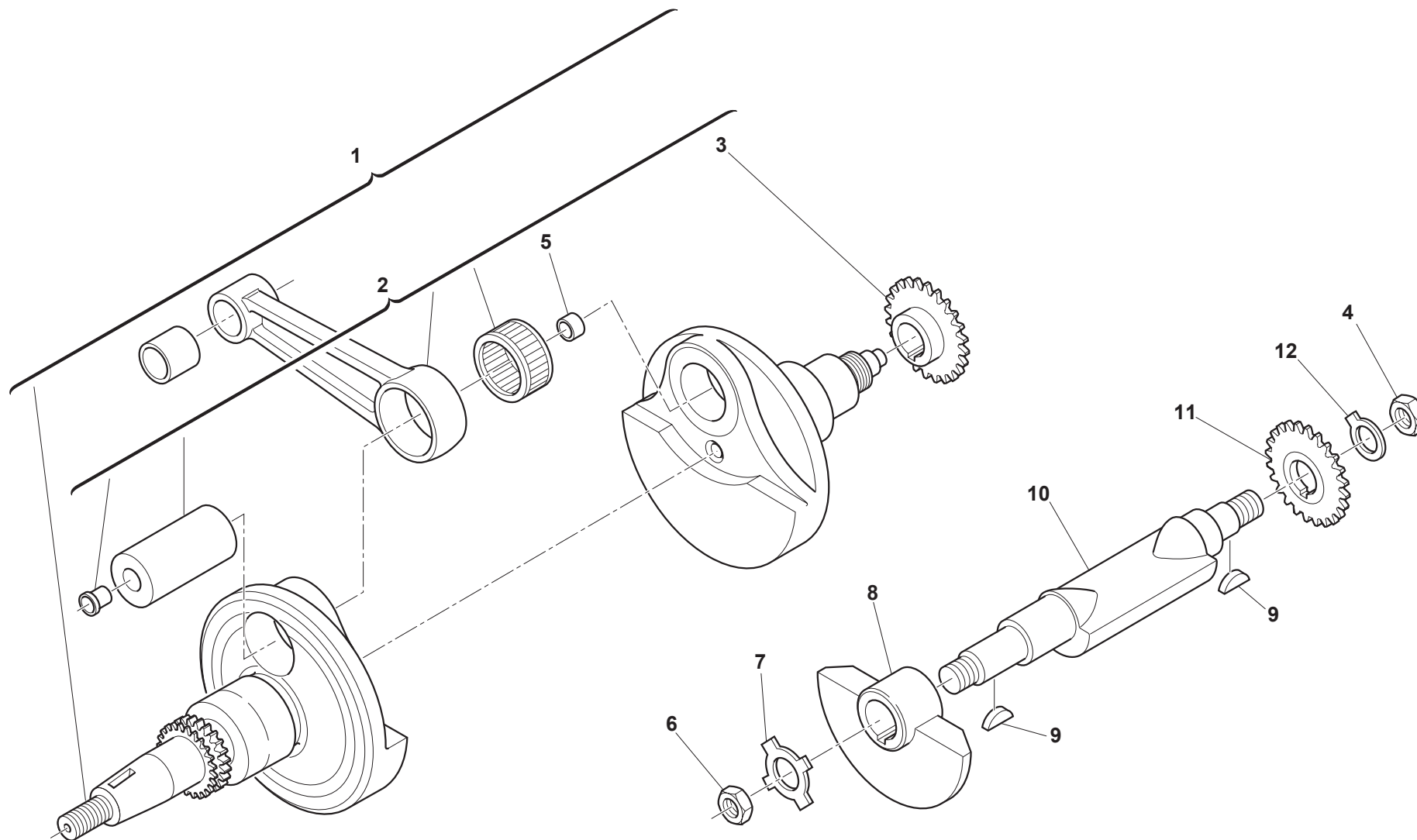

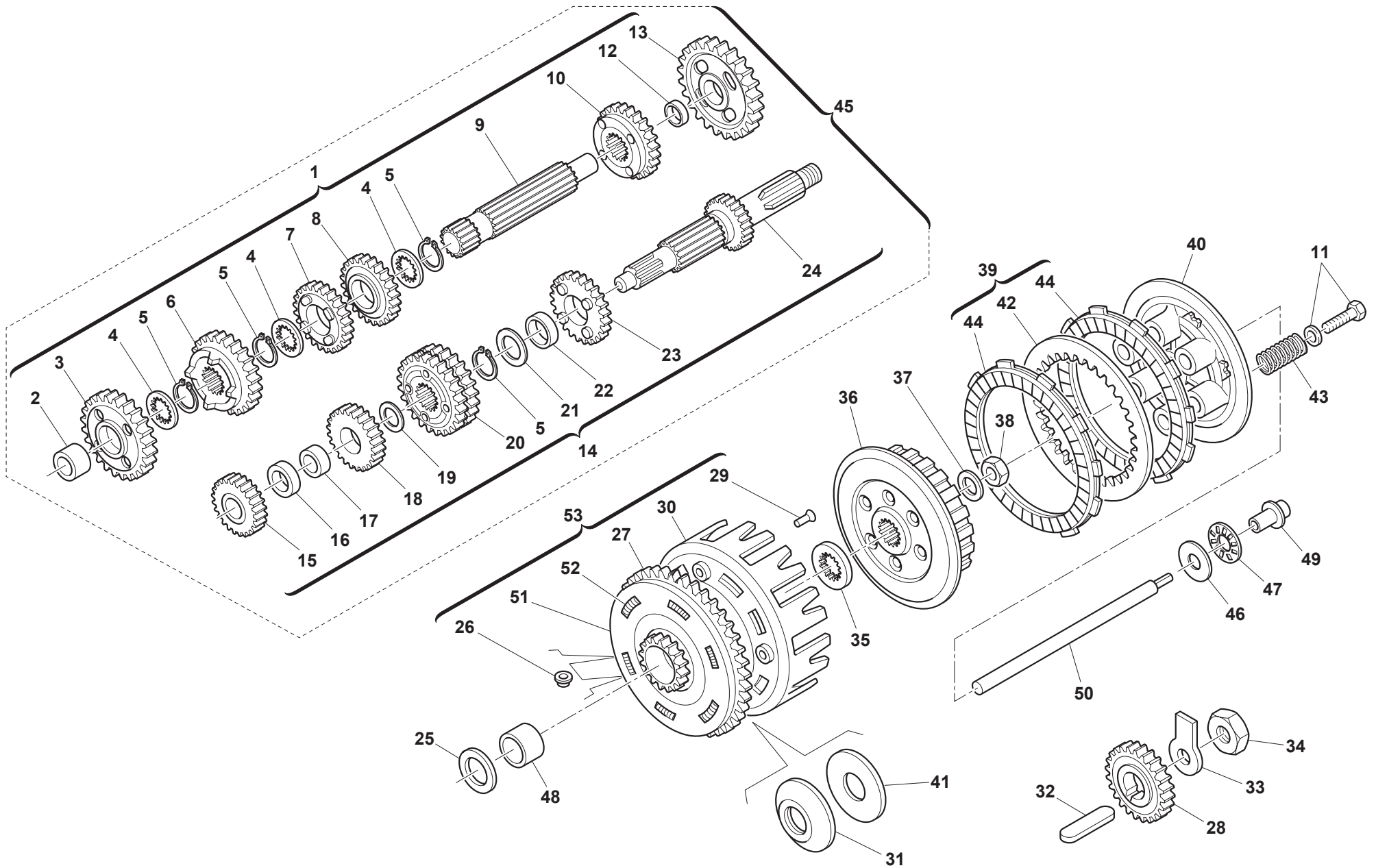

**RS-SM 650R/2016**

TRASMISSIONE PRIMARIA, FRIZIONE - PRIMARY DRIVE, CLUTCH
TRANSMISSION PRIMAIRE, EMBRAYAGE
PRIMÄRÜBERSETZUNG, KUPPLUNG - TRANSMISION PRIMARIA, EMBRAGUE

TAVOLA
DRAWING
TABLE
BILD
TABLA**5**

Note Notes Notes Marke Notas	Pos. No. N. Index Pos.	N. Cod. Code No. Nr. Code Code Nr N. Cod.	Q.tà Q.ty M.ge C.ad	DENOMINAZIONE	NAME	DESIGNATION	BESHREIBUNG	DENOMINACION
	1	M000A00706	1	ALBERO SECONDARIO COMPLETO	COUNTER SHAFT ASSY	ARBRE SECONDAIRE COMPLET	NEBENGETRIEBEWELLE KOMPL.	ARBOL SECUNDARIO CAMBIO COMPLETO
	2	800063822	1	BOCCOLA 28X25X7	BUSH 28X25X7	DOUILLE 28X25X7	BUCHSE 28X25X7	BUJE 28X25X7
	3	800074864	1	INGRANAGGIO CONDOTTO 2A Z29	DRIVEN GEAR 2ND SPEED T29	ENGRENAGE ENTRAINE 2EME VITESSE D29	ANGETRIEBENES ZAHNRAD 2. GESCHWIND.Z29	ENGRANAJE ACCIONADO 2NDA VELOCIDAD D29
	4	161171701	3	RONDELLA	WASHER	RONDELLE	SCHEIBE	ARANDELA
	5	66N021211	4	ANELLO SEEGER 25MM DIN471	CIRCLIP 25MM DIN471	CIRCLIP 25MM DIN471	SPRENGRING 25MM DIN471	ANILLO SEEGER 25MM DIN471
	6	M000P00708	1	INGRANAGGIO CONDOTTO 3A Z27	DRIVEN GEAR 3RD SPEED T27	ENGRENAGE ENTRAINE 3EME VITESSE D27	ANGETRIEBENES ZAHNRAD 3. GESCHWIND. Z27	ENGRANAJE ACCIONADO 3ERA VELOCIDAD D27
	7	M000P00709	1	INGRANAGGIO CONDOTTO 6A	DRIVEN GEAR 6TH SPEED	ENGRENAGE ENTRAINE 6EME VITESSE	ANGETRIEBENES ZAHNRAD 6, GESCHWIND.	ENGRANAJE ACCIONADO 6A VELOCIDAD
	8	M000P00710	1	INGRANAGGIO CONDOTTO 5A Z22	DRIVEN GEAR 5TH SPEED T22	ENGRENAGE ENTRAINE 5EME VITESSE D22	ANGETRIEBENES ZAHNRAD 5. GESCHWIND. Z27	ENGRANAJE ACCIONADO 5A VELOCIDAD D22
	9	M000P00707	1	ALBERO SECONDARIO	COUNTER SHAFT	ARBRE SECONDAIRE	ANTRIEBSWELLE	ARBOL SECUNDARIO
	10	M000P00711	1	INGRANAGGIO CONDOTTO 4A Z24	DRIVEN GEAR 4TH SPEED T:24	ENGRENAGE ENTRAINE 4EME VITESSE D24	ANGETRIEBENES ZAHNRAD 4. GESCHWIND. Z24	ENGRANAJE ACCIONADO 4A VELOCIDAD D24
	11	M000P00464	6	VITE CON RONDELLA	SCREW WITH WASHER	VIS AVEC RONDELLE	SCHRAUBE MIT SCHEIBE	TORNILLO CON ARANDELA
	12	161241501	1	BRONZINA INGRANAGGIO	BUSH, GEAR	COUSSINET ENGRANAGE	GLEITLAGER, ZHANRAD	COJINETE PLANO ENGRANAJE
	13	800074862	1	INGRANAGGIO CONDOTTO 1A Z34	DRIVEN GEAR 1ST SPEED T34	ENGRENAGE ENTRAINE 1ERE VITESSE D34	ANGETRIEBENES ZAHNRAD 1. GESCHWIND. Z34	ENGRANAJE ACCIONADO 1ERA VELOCIDAD D34
	14	M000A00703	1	ALBERO PRIMARIO COMPLETO	MAIN SHAFT ASSY	ARBRE PRIMAIRE COMPLET	KOMPLETTE HAUPTWELLE	ARBOL PRIMARIO COMPLETO
	15	800074863	1	INGRANAGGIO CONDUTTORE 2A Z16	GEAR INPUT 2ND 16T	ENGRENAGE MENANT 2EME VITESSE D16	TREIBENDES ZAHNRAD 2. GESCHWIND. Z16	ENGRANAJE CONDUCTOR 2NDA VELOCIDAD D16
	16	161248101	1	DISTANZIALE	SPACER	ENTRETOISE	ABSTANDHALTER	DISTANCIADOR
	17	161248001	1	BRONZINA INGRANAGGIO	BUSH, GEAR	COUSSINET ENGRANAGE	GLEITLAGER, ZHANRAD	COJINETE PLANO ENGRANAJE
	18	800079688	1	INGRANAGGIO CONDUTTORE 3A Z20	GEAR DRIVE 3RD SPEED T20	ENGRENAGE MENANT 3EME VITESSE D20	TREIBENDES ZAHNRAD 3. GESCHWIND. Z20	ENGRANAJE CONDUCTOR 3ERA VELOCIDAD D20
	19	161284201	1	RONDELLA	WASHER	RONDELLE	SCHEIBE	ARANDELA
	20	M000P00705	1	INGRANAGGIO CONDUTTORE 5A-6A	GEAR DRIVE 5-6TH SPEED	ENGRENAGE MENANT 5-6EME VITESSE	TREIBENDES ZAHNRAD 5-6, GESCHWIND.	ENGRANAJE CONDUCTOR 5-6A VEL.
	21	8H0036022	1	RONDELLA RASAMENTO 32X25,1X1,0 MM	THRUST WASHER 32X25,1X1,0 MM	RONDELLE DE BUTEE 32X25,1X1,0 MM	DISTANZSCHEIBE 32X25,1X1,0 MM	ARANDELA DE SEPARACION 32X25,1X1,0 MM
	22	800063821	1	BOCCOLA 28X25X9,9	BUSH 28X25X9,9	DOUILLE 28X25X9,9	BUCHSE 28X25X9,9	BUJE 28X25X9,9
	23	800079686	1	INGRANAGGIO CONDUTTORE 4A Z22	GEAR, 4TH DRIVE NT22	ENGRENAGE MENANT 4EME VITESSE D22	TREIBENDES ZAHNRAD 4. GESCHWIND. Z22	ENGRANAJE CONDUCTOR 4A VELOCIDAD D22
	24	M000P00704	1	ALBERO PRIMARIO Z13	MAIN SHAFT T13	ARBRE PRIMAIRE D13	HAUPTWELLE Z13	ARBOL PRIMARIO CAMBIO D13
	25	8E0030053	1	RONDELLA RASAMENTO 38X25,2	THRUST WASHER 38X25,2	RONDELLE DE BUTEE 38X25,2	DISTANZSCHEIBE 38X25,2	ARANDELA DE SEPARACION 38X25,2
	26	800054463	12	SCODELLINO	CUP	COUPELLE	EINSTELLE	COPELA
	27	8000H2945	1	INGRANAGGIO CONDOTTO Z16/75	GEAR, DRIVEN T16/75	ENGRENAGE ENTRAINE D16/75	ANGETRIEBENES ZAHNRAD Z16/75	ENGRANAJE ACCIONADO D16/75
	28	800097935	1	INGRANAGGIO CONDUTTORE Z 32	GEAR DRIVE T32	ENGRENAGE MENANT D32	TREIBENDES ZAHNRAD Z32	ENGRANAJE CONDUCTOR D32
	29	800036848	3	RIBATTINO A TESTA SVASATA UNI 752	RIVET UNI 752	RIVET UNI 752	NIET UNI 752	REMACHE UNI 752
	30	800084424	1	CAMPANA FRIZIONE NUDA	CLUTCH HOUSING	CLOCHE EMBRAYAGE	KUPPLUNGSKASTEN	CAMPANA EMBRAGUE
	31	800048564	1	MOLLAA TAZZA	WASHER BELLEVILLE	RONDELLE BELLEVILLE	SCHEIBE, BELLEVILLE	ARANDELA BELLEVILLE
	32	800022426	1	CHIAVETTA INGRANAGGIO CONDUTTORE	KEY	CLAVETTE	KEIL	CHAVETA
	33	800086007	1	RONDELLA DI SICUREZZA	WASHER, LOCK	RONDELLE VERROULAGE	SICHERUNGSSCHEIBE	ARANDELA CIERRE

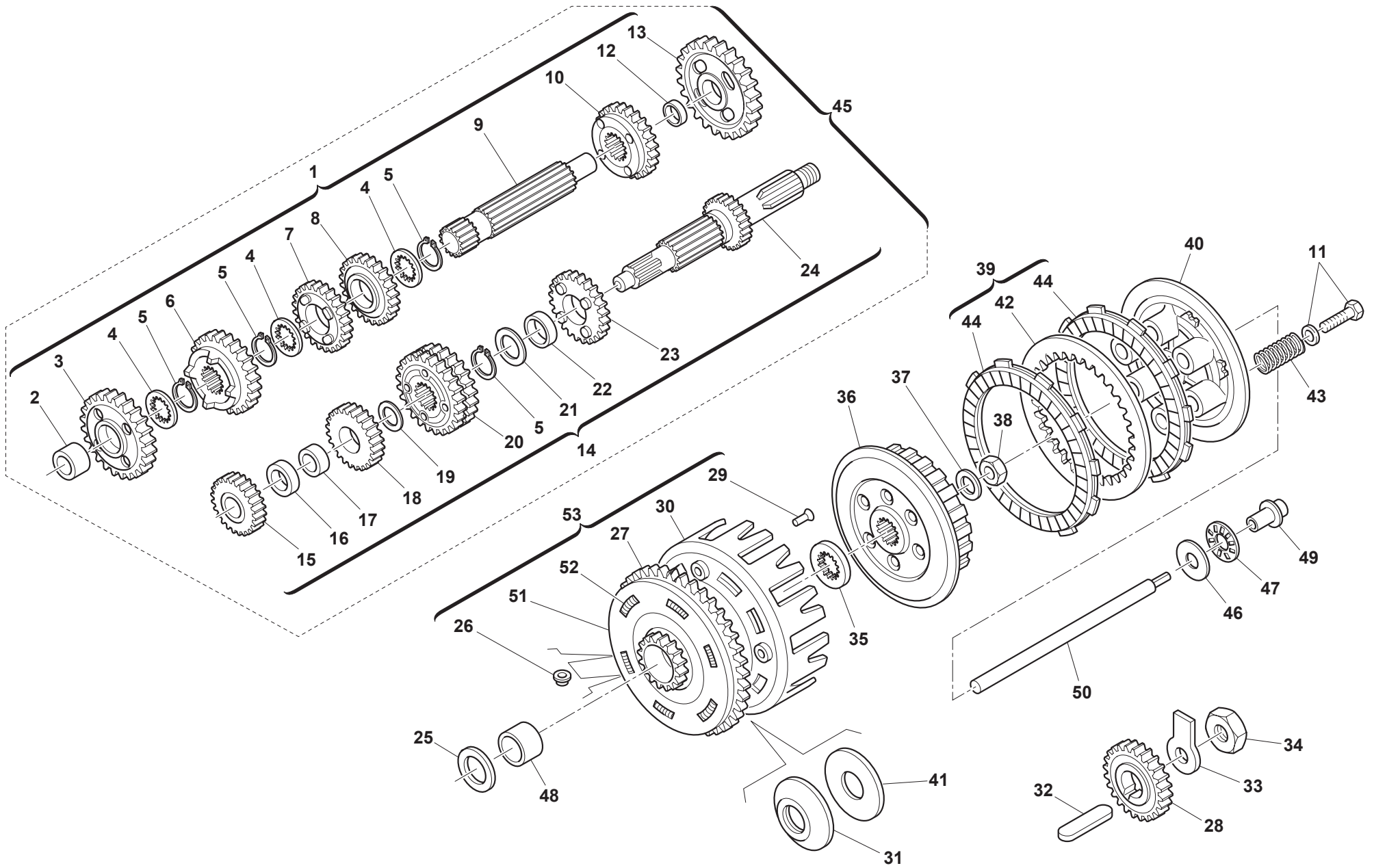

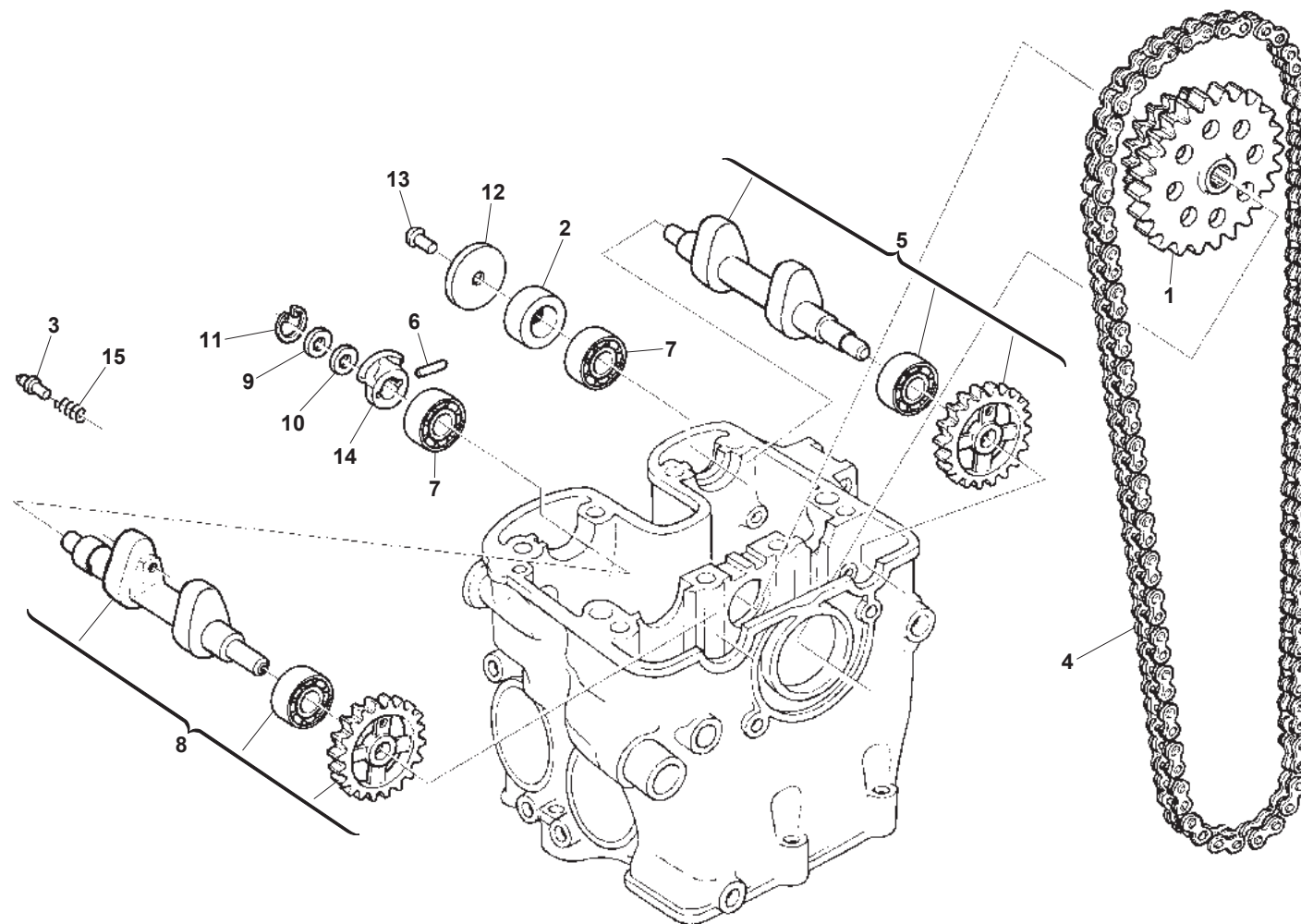

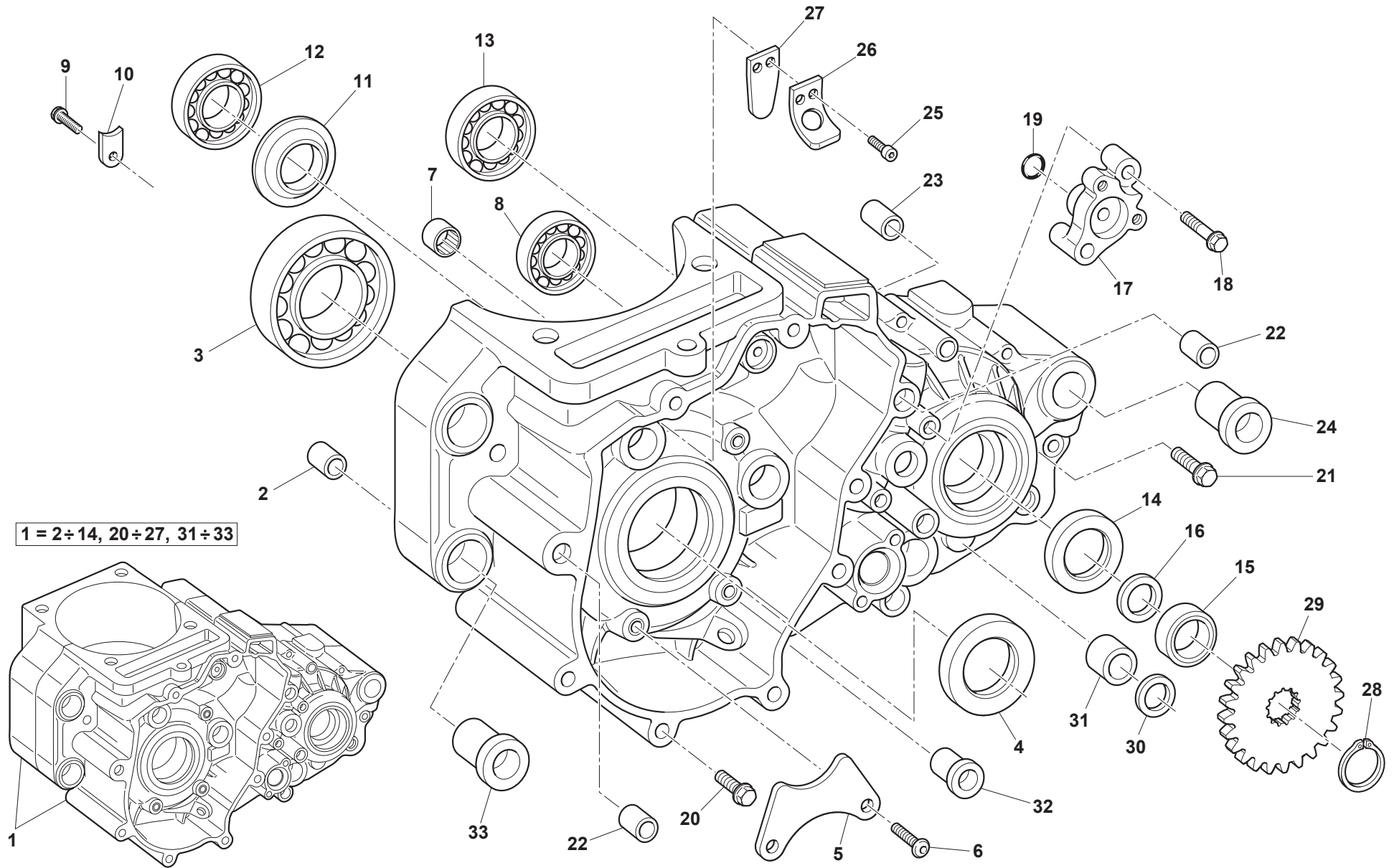



RS-SM 650R/2016

SEMICARTER SINISTRO - L.H. HALF CRANKCASE CARTER G. - GEHAUSEDECKEL L. BANCADA IZQ.

TAVOLA
DRAWING
TABLE
BILD
TABLA

7

Note Notes Notes Marke Notas	Pos. No. N. Index Pos.	N. Cod. Code No. Nr. Code Code Nr N. Cod.	Q.tà Q.ty M.ge C.ad	DENOMINAZIONE	NAME	DESIGNATION	BESHREIBUNG	DENOMINACION
	1	M000A00102	1	CARTER MOTORE	CRANKCASE SET	CARTER MOTEUR	KURBELWELLENGEHAUSE	CARTER MOTOR
	2	161077601	1	BOCCOLA 13X8,5X15	BUSH 13X8.5X15	DOUILLE 13X8,5X15	BUCHSE 13X8,5X15	BUJE 13X8,5X15
	3	800085380	1	CUSCINETTO A SFERE 85X45X19	BEARING, BALL 85X45X19	ROULEMENT A BILLES 85X45X19	KUGELLAGER 85X45X19	COJINETE DE BOLAS 85X45X19
	4	800085381	1	PARAOLIO 60X45X7	OIL SEAL 60X45X7	BAGUE D'ETANCHEITE 60X45X7	WELLENDICHRING 60X45X7	RETEN DE ACEITE 60X45X7
	5	800085383	1	PIASTRINA RITEGNO PARAOLIO	PLATE HOLDING OIL SEAL	PLAQUETTE FIXATION BAGUE ETANCHEITE	HALTEPLATTE WELLENDICHRING	PLACA SUJECION RETEN ACEITE
	6	ZA0067997	2	VITE TEF M5X0,8X16 CH8	SCREW TEF M5X0.8X16 CH8	VIS TEF M5X0,8X16 CH8	SCHRAUBE TEF M5X0,8X16 CH8	TORNILLO TEF M5X0,8X16 CH8
	7	800062200	1	ASTUCCIO A RULLI 24X30X7,5	BEARING, NEEDLE 24X30X7.5	ROULEMENT A AIGUILLES 24X30X7,5	NADELLAGER 24X30X7,5	COJINETE DE AGUJAS 24X30X7,5
	8	800019768	1	CUSCINETTO A SFERE 42X15X13	BEARING, BALL 42X15X13	ROULEMENT A BILLES 42X15X13	KUGELLAGER 42X15X13	COJINETE DE BOLAS 42X15X13
	9	ZA0066525	1	VITE TEF M5X0,8X16 CH8	SCREW TEF M5X0.8X16 CH8	VIS TEF M5X0,8X16 CH8	SCHRAUBE TEF M5X0,8X16 CH8	TORNILLO TEF M5X0,8X16 CH8
	10	800081663	1	PIASTRINA RITEGNO	RETAINING PLATE	PLAQUE RETENUE	HALTEBLECH	CHAPA RETENCION
	11	800072966	1	SCHERMO TENUTA 204 JV	SEAL, MECHANICAL NUP 204 JV	TENUE MECANIQUE NUP 204 JV	MECHANISCHE DICHTUNG NUP 204 JV	SELLO MECANICO NUP 204 JV
	12	800072964	1	CUSCINETTO A RULLI 20X47X14	ROLLERS BEARING 20X47X14	ROULEMENT A ROULEAUX 20X47X14	ROLLENLAGER 20X47X14	COJINETE DE RODILLOS 20X47X14
	13	800043789	1	CUSCINETTO A RULLI NU205	BEARING, ROLLER NU205	ROULEMENT A ROULEAUX NU205	ROLLENLAGER NU205	COJINETE RODILLOS NU205
	14	800059977	1	PARAOLIO 32X40X5	SEAL, OIL 32X40X5	BAGUE D'ETANCHEITE 32X40X5	WELLENDICHRING 32X40X5	RETEN DE ACEITE 32X40X5
	15	800060464	1	DISTANZIALE 32X28,2X25X10,3	SPACER 32X28.2X25X10.3	ENTRETOISE 32X28,2X25X10,3	ABSTANDHALTER 32X28,2X25X10,3	DISTANCIADOR 32X28,2X25X10,3
	16	800023110	1	ANELLO O-RING 2100 28,68X1,72	O-RING 2100 28.68X1.72	JOINT TORIQUE 2100 28,68X1,72	O-RING 2100 28,68X1,72	JUNTA TORICA 2100 28,68X1,72
	17	80A0H0994	1	FLANGIA SPINGIFRIZIONE IDRAULICO	FLANGE, CYLINDER CLUTCH PRESSURE	BRIDE CYLINDRE POUSSEE EMBRAYAGE	FLANSCH, KUPPLUNG SZYLINDERDRUCH	BRIDA CILINDRO EMPUJADOR EMBRAGUE
	18	Z00062730	2	VITE TEF M6X1X30	SCREW TEF M6X1X30	VIS TEF M6X1X30	SCHRAUBE TEF M6X1X30	TORNILLO TEF M6X1X30
	19	8B0023109	1	ANELLO O-RING	O-RING	JOINT TORIQUE	O-RING	JUNTA TORICA
	20	ZB0067545	9	VITE TEF M6X1X55 CH8	SCREW TEF M6X1X55 CH8	VIS TEF M6X1X55 CH8	SCHRAUBE TEF M6X1X55 CH8	TORNILLO TEF M6X1X55 CH8
	21	ZC0067545	2	VITE TEF M6X1X65 CH8	SCREW TEF M6X1X65 CH8	VIS TEF M6X1X65 CH8	SCHRAUBE TEF M6X1X65 CH8	TORNILLO TEF M6X1X65 CH8
	22	800007719	2	GRANO RIFERIMENTO 10X7,2X16	PIN, DOWEL 10X7.2X16	GOUJON DE REFERENCE 10X7,2X16	BEZUGSSTIFT 10X7,2X16	ESPIGA DE REFERENCIA 10X7,2X16
	23	161459002	1	BOCCOLA 22X17,5X15	BUSH 22X17.5X15	DOUILLE 22X17,5X15	BUCHSE 22X17,5X15	BUJE 22X17,5X15
	24	800071154	1	BOCCOLA FLANGIATA 32X22X17,2	BUSH WITH COLLAR 32X22X17.2	DOUILLE BRIDEE 32X22X17,2	GEFLANSCHBUCHSE 32X22X17,2	CASQUILLO REBORDEADO 32X22X17,2
	25	60ND02866	2	VITE TCI M4X0,7X6	SCREW TCI M4X0.7X6	VIS TCI M4X0,7X6	SCHRAUBE TCI M4X0,7X6	TORNILLO TCI M4X0,7X6
	26	161510501	1	FERMO PETALO LAMELLA	STOPPER, REED VALVE	PLAQUE ARRET CLAPET	STOPPLATTE LAMELLENVENTIL	PLACA RETENCION VALVULA LAMINAS
	27	161534801	1	VALVOLA LAMELLARE	READ VALVE COMP	SOUPAPE CLAPET	LAMELLENVENTIL	VALVULA LAMINAS
	28	66N021211	1	ANELLO SEEGER 25MM DIN471	CIRCLIP 25MM DIN471	CIRCLIP 25MM DIN471	SPRENGRING 25MM DIN471	ANILLO SEEGER 25MM DIN471
	29	M000P00712	1	PIGNONE Z15	SPROCKET, CHAIN T15	PIGNON CHAINE Z15	KETTENRITZEL Z15	PINON CADENA Z15
	30	800034451	1	PARAOLIO 12X19X5	OIL SEAL 12X19X5	BAGUE D'ETANCHEITE 12X19X5	WELLENDICHRING 12X19X5	RETEN DE ACEITE 12X19X5
	31	8A0065847	1	BOCCOLA	BUSH	DOUILLE	BUCHSE	BUJE
	32	161077701	1	BOCCOLA FLANGIATA	BUSH WITH COLLAR	DOUILLE BRIDEE	GEFLANSCHBUCHSE	CASQUILLO REBORDEADO
	33	161077702	2	BOCCOLA FLANGIATA 20X12,8X8	BUSH WITH COLLAR 20X12.8X8	DOUILLE BRIDEE 20X12,8X8	GEFLANSCHBUCHSE 20X12,8X8	CASQUILLO REBORDEADO 20X12,8X8

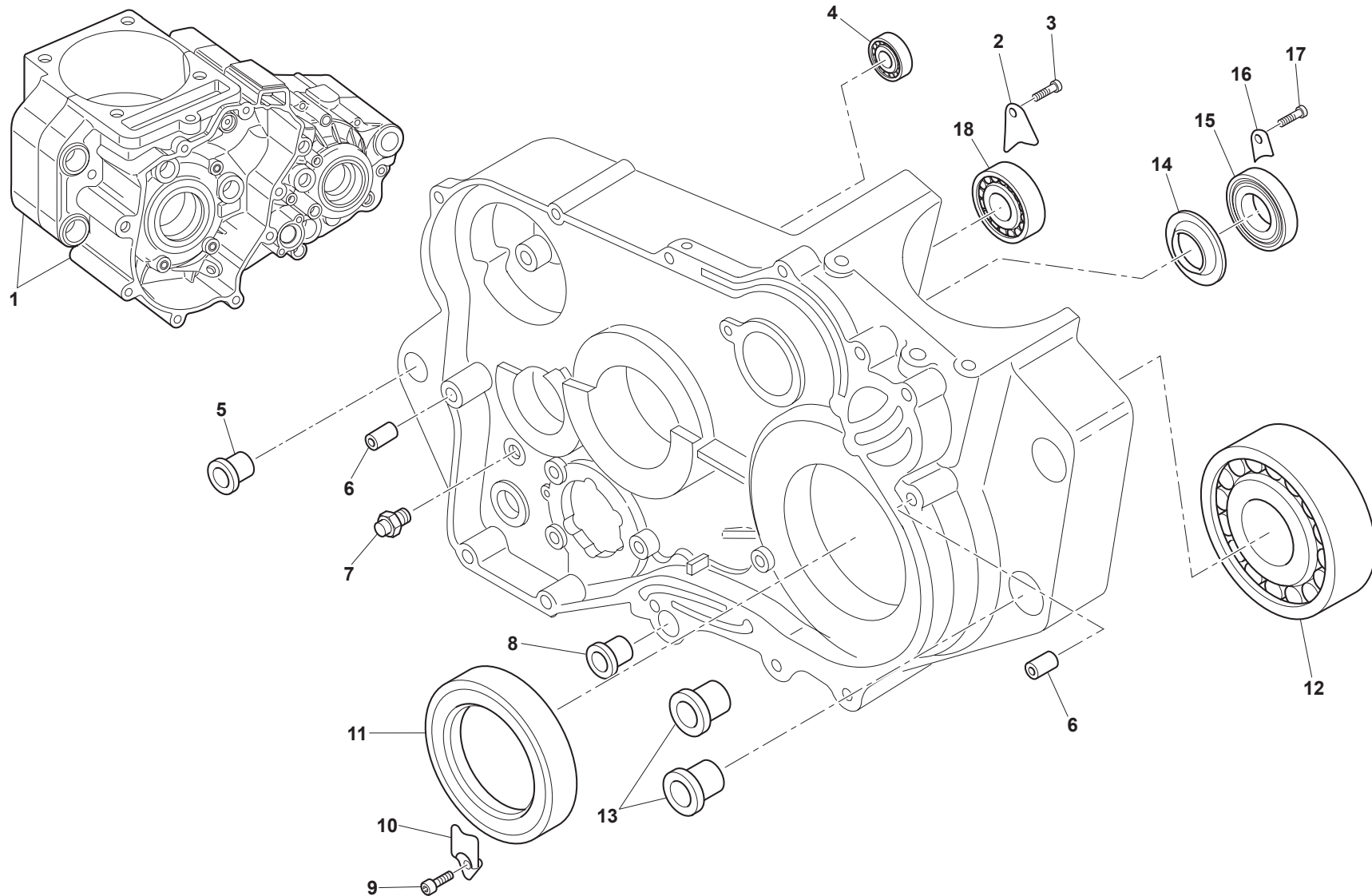

**RS-SM 650R/2016**
**SEMICARTER DESTRO - R.H. HALF CRANKCASE
 CARTER D. - GEHAUSEDECKEL R.
 BANCADA DER.**
TAVOLA
DRAWING
TABLE
BILD
TABLA**8**

Note Notes Marke Notas	Pos. No. N. Index Pos.	N. Cod. Code No. Nr. Code Code Nr N. Cod.	Q.tà Q.ty Q.te M.ge C.ad	DENOMINAZIONE	NAME	DESIGNATION	BESHREIBUNG	DENOMINACION
	1	M000A00102	1	CARTER MOTORE	CRANKCASE SET	CARTER MOTEUR	KURBELWELLENGEHAUSE	CARTER MOTOR
	2	800051746	1	PIASTRINA RITEGNO CUSCINETTO	RETAINER, BEARING	PLAQUE ARRET ROULEMENT	STOPPLATTE, LAGER	PLACA RETENCION COJINETE
	3	Z00042643	1	VITE SVASATA M6X1,00X8,5	SCREW M6X1.00X8.5	VIS M6X1,00X8,5	SCHRAUBE M6X1,00X8,5	TORNILLO M6X1,00X8,5
	4	800072962	1	CUSCINETTO A SFERE 47X17X14	BEARING, BALL 47X17X14	ROULEMENT A BILLES 47X17X14	KUGELLAGER 47X17X14	COJINETE DE BOLAS 47X17X14
OPT	4	800010290	1	CUSCINETTO A SFERE 47X17X14	BEARING, BALL 47X17X14	ROULEMENT A BILLES 47X17X14	KUGELLAGER 47X17X14	COJINETE DE BOLAS 47X17X14
	5	800071154	1	BOCCOLA FLANGIATA 32X22X17,2	BUSH WITH COLLAR 32X22X17.2	DOUILLE BRIDEE 32X22X17,2	GEFLANSCHBUCHSE 32X22X17,2	CASQUILLO REBORDEADO 32X22X17,2
	6	800007719	2	GRANO RIFERIMENTO 10X7,2X16	PIN, DOWEL 10X7.2X16	GOUJON DE REFERENCE 10X7,2X16	BEZUGSSTIFT 10X7,2X16	ESPIGA DE REFERENCIA 10X7,2X16
	7	8A0066953	1	PERNO	PIN	PIVOT	BOLZEN	PERNO
	8	161077701	1	BOCCOLA FLANGIATA	BUSH WITH COLLAR	DOUILLE BRIDEE	GEFLANSCHBUCHSE	CASQUILLO REBORDEADO
	9	Z00062725	1	VITE TEF M6X1X10 CH8	SCREW TEF M6X1.00X10 CH8	VIS TEF M6X1,00X10 CH8	SCHRAUBE TEF M6X1,00X10 CH8	TORNILLO TEF M6X1,00X10 CH8
	10	800085382	1	PIASTRINA RITEGNO PARAOLIO	PLATE HOLDING OIL SEAL	PLAQUETTE FIXATION BAGUE ETANCHEITE	HALTEPLATTE WELLENDICHRING	PLACA SUJECION RETEN ACEITE
	11	800085381	1	PARAOLIO 60X45X7	OIL SEAL 60X45X7	BAGUE D'ETANCHEITE 60X45X7	WELLENDICHRING 60X45X7	RETEN DE ACEITE 60X45X7
	12	800085380	1	CUSCINETTO A SFERE 85X45X19	BEARING, BALL 85X45X19	ROULEMENT A BILLES 85X45X19	KUGELLAGER 85X45X19	COJINETE DE BOLAS 85X45X19
	13	161077702	2	BOCCOLA FLANGIATA 20X12,8X8	BUSH WITH COLLAR 20X12.8X8	DOUILLE BRIDEE 20X12,8X8	GEFLANSCHBUCHSE 20X12,8X8	CASQUILLO REBORDEADO 20X12,8X8
	14	8B0072966	1	SCHERMO TENUTA 6204 Z JV	SEAL, MECHANICAL 6204 Z JV	TENUE MECANIQUE 6204 Z JV	MECHANISCHE DICHTUNG 6204 Z JV	SELLO MECANICO 6204 Z JV
	15	800076680	1	CUSCINETTO A SFERE 20X47X14	BEARING, BALL 20X47X14	ROULEMENT A BILLES 20X47X14	KUGELLAGER 20X47X14	COJINETE DE BOLAS 20X47X14
	16	800081663	1	PIASTRINA RITEGNO	RETAINING PLATE	PLAQUE RETENUE	HALTEBLECH	CHAPA RETENCION
	17	ZA0066525	1	VITE TEF M5X0,8X16 CH8	SCREW TEF M5X0.8X16 CH8	VIS TEF M5X0,8X16 CH8	SCHRAUBE TEF M5X0,8X16 CH8	TORNILLO TEF M5X0,8X16 CH8
	18	8A0059975	1	CUSCINETTO A SFERE 52X25X15	BEARING, BALL 52X25X15	ROULEMENT A BILLES 52X25X15	KUGELLAGER 52X25X15	COJINETE DE BOLAS 52X25X15

SENSO DI MARCIA
DIRECTION OF TRAVEL
DIRECTION DE VOYAGE
FAHRTRICHTUNG
DIRECCIÓN DE VIAJE

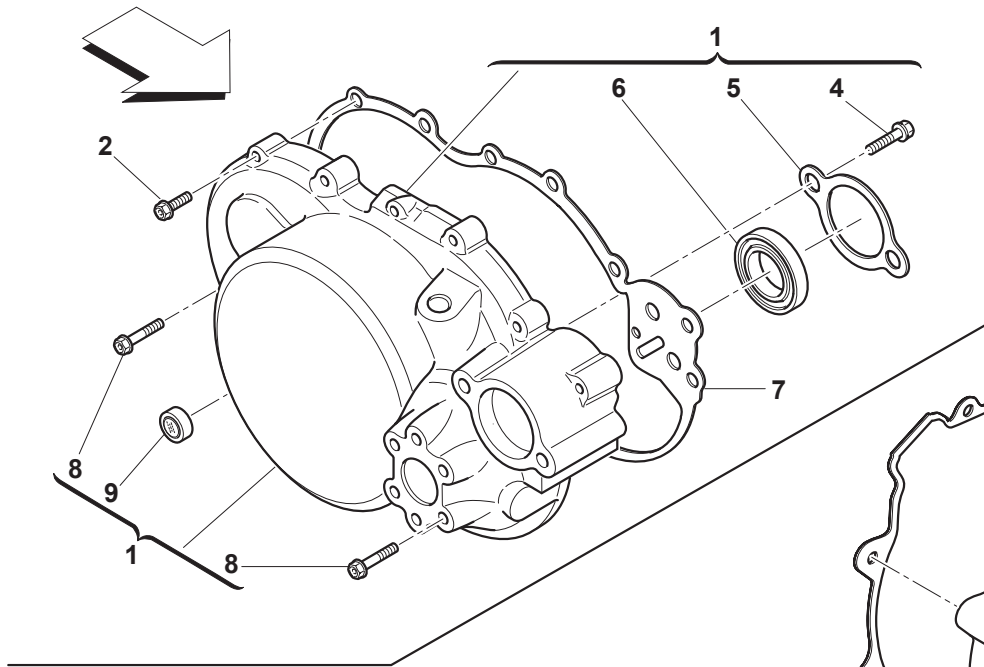

SENSO DI MARCIA
DIRECTION OF TRAVEL
DIRECTION DE VOYAGE
FAHRTRICHTUNG
DIRECCIÓN DE VIAJE

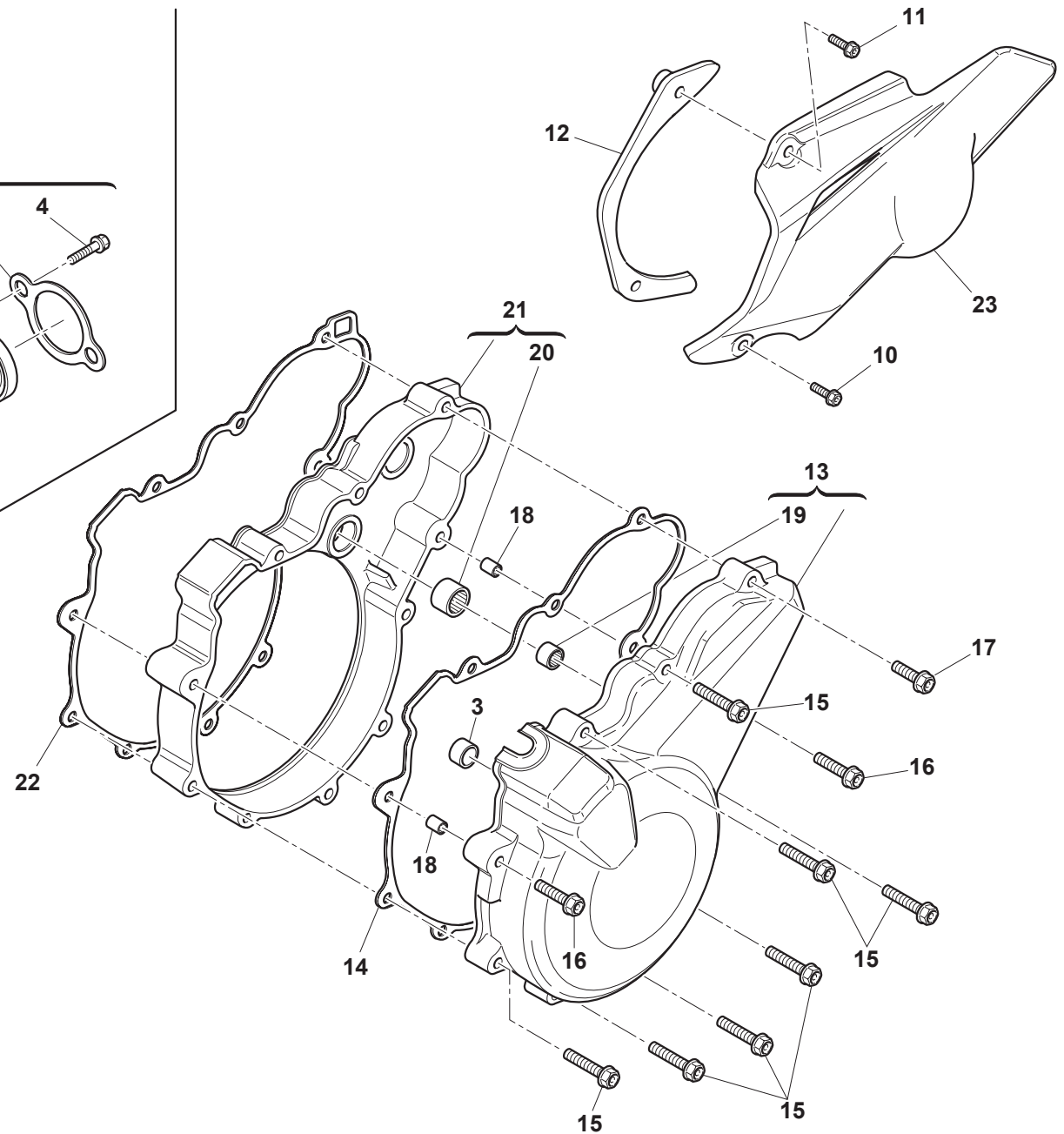

**RS-SM 650R/2016**
COPERCHI BASAMENTO - CRANKCASE COVERS
COUVERCLES CARTER - GEHAUSEDECKEL
TAPAS BANCADA
TAVOLA
DRAWING
TABLE
BILD
TABLA**9**

Note Notes Marke Notas	Pos. No. N. Index Pos.	N. Cod. Code No. Nr. Code Code Nr N. Cod.	Q.tà Q.ty Q.te M.ge C.ad	DENOMINAZIONE	NAME	DESIGNATION	BESHREIBUNG	DENOMINACION
	1	M000A00106	1	COPERCHIO FRIZIONE	COVER, CLUTCH	COUVERCLE EMBRAYAGE	KUPPLUNGSDECKEL	CUBIERTA EMBRAGUE
	2	Z00062730	11	VITE TEF M6X1X40	SCREW TEF M6X1X40	VIS TEF M6X1X40	SCHRAUBE TEF M6X1X40	TORNILLO TEF M6X1X40
	3	800002124	1	CUSCINETTO A SFERE 6201C3 32X12X10	BALL BEARING 6201C3 32X12X10	ROULEMENT A BILLES 6201C3 32X12X10	KUGELLAGER 6201C3 32X12X10	COJINETE DE BOLAS 6201C3 32X12X10
	4	Z00049608	2	VITE TSEI M5X0,8X10	SCREW TSEI M5X0,8X10	VIS TSEI M5X0,8X10	SCHRAUBE TSEI M5X0,8X10	TORNILLO TSEI M5X0,8X10
	5	800084817	1	FLANGIA PARAOLIO	COVER, OIL SEAL	PLAQUE ARRET	STOPPLATTE	PLACA RETENCION
	6	800062209	1	PARAOLIO 17X28X7	OIL SEAL 17X28X7	BAGUE D'ETANCHEITE 17X28X7	WELLENDICHRING 17X28X7	RETEN DE ACEITE 17X28X7
	7	M000P00108	1	GUARNIZIONE COPERCHIO FRIZIONE	GASKET, CLUTCH COVER	JOINT COUVERCLE EMBRAYAGE	DICHTUNG KUPPLUNGSDECKEL	JUNTA CUBIERTA EMBRAGUE
	8	ZC0067545	2	VITE TEF M6X1X65 CH8	SCREW TEF M6X1X65 CH8	VIS TEF M6X1X65 CH8	SCHRAUBE TEF M6X1X65 CH8	TORNILLO TEF M6X1X65 CH8
	9	800073529	1	VETRINO SPIA LIVELLO OLIO	WINDOW, OIL LEVEL CHECK	HUBLOT NIVEAU HUILE	SCHAUGLAS, OELKONTROLL	MIRILLA NIVEL ACEITE
	10	Z00067545	1	VITE TEF M6X1X25 CH8	SCREW TEF M6X1X25 CH8	VIS TEF M6X1X25 CH8	SCHRAUBE TEF M6X1X25 CH8	TORNILLO TEF M6X1X25 CH8
	11	ZA0067545	1	VITE TEF M6X1X45	SCREW TEF M6X1X45	VIS TEF M6X1X45	SCHRAUBE TEF M6X1X45	TORNILLO TEF M6X1X45
	12	8000H2207	1	PIASTRINA	PLATE	PLAQUETTE	PLAETTCHEN	PLETINA
	13	M000A00105	1	COPERCHIO GENERATORE	COVER, GENERATOR	COUVERCLE GENERATEUR	DECKEL, STROMGENERATORS	CUBIERTA GENERADOR
	14	8000A1368	1	GUARNIZIONE COPERCHIO GENERATORE	GASKET, GENERATOR COVER	JOINT COUVERCLE GENERATEUR	DICHTUNG, STROMGENERATOR DECKEL	JUNTA CUBIERTA GENERADOR
	15	ZB0067545	7	VITE TEF M6X1X55 CH8	SCREW TEF M6X1X55 CH8	VIS TEF M6X1X55 CH8	SCHRAUBE TEF M6X1X55 CH8	TORNILLO TEF M6X1X55 CH8
	16	ZC0067545	2	VITE TEF M6X1X65 CH8	SCREW TEF M6X1X65 CH8	VIS TEF M6X1X65 CH8	SCHRAUBE TEF M6X1X65 CH8	TORNILLO TEF M6X1X65 CH8
	17	Z00062730	1	VITE TE M6X1X30 CH8	SCREW TE M6X1X30 CH8	VIS TE M6X1X30 CH8	SCHRAUBE TE M6X1X30 CH8	TORNILLO TE M6X1X30 CH8
	18	M000P00423	2	GRANO RIFERIMENTO 10X7,2	PIN, DOWEL 10X7,2	GOIJON DE REFERENCE 10X7,2	BEZUGSSTIFT 10X7,2	ESPIGA DE REFERENCIA 10X7,2
	19	800086243	1	ASTUCCIO A RULLI HK1015	BEARING, NEEDLE HK1015	ROULEMENT A AIGUILLES HK1015	NADELLAGER HK1015	COJINETE DE AGUJAS HK1015
	20	800033422	1	ASTUCCIO A RULLI HK1412	BEARING, NEEDLE HK1412	ROULEMENT A AIGUILLES HK1412	NADELLAGER HK1412	COJINETE DE AGUJAS HK1412
	21	8C0086246	1	SUPPORTO MOTORINO AVVIAMENTO	BRACKET STARTING MOTOR	SUPPORT, DEMARREUR ELECTRIQUE	HALTER, ANLASSERMOTOR	SOPORTE MOTOR ARRANQUE
	22	8000A1367	1	GUARNIZIONE FLANGIA MOTORINO AVVIAMENTO	GASKET	JOINT	DICHTUNG	JUNTA
	23	F000P00067	1	COPERCHIO PIGNONE	COVER, SPROCKET	COUVERCLE PIGNON CHAINE	DECKEL, RITZEL	CUBIERTA PINON CADENA

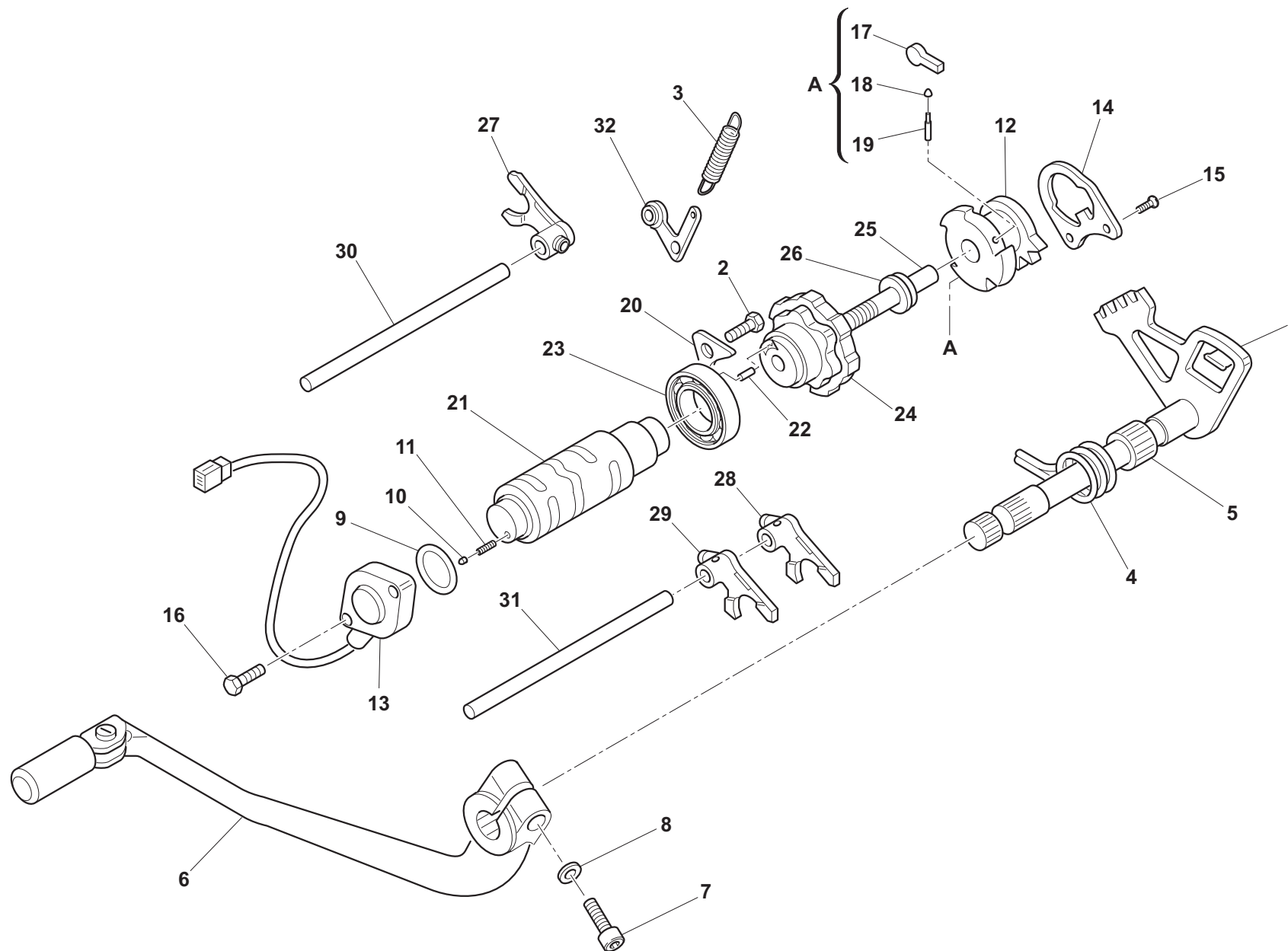



RS-SM 650R/2016

COMANDO CAMBIO - GEARSHIFT MECHANISM COMMANDE DE VITESSE - GANGSCHALTUNG MANDO CAMBIO

TAVOLA
DRAWING
TABLE
BILD
TABLA

10

Note Notes Marke Notas	Pos. No. N. Index Pos.	N. Cod. Code No. Nr. Code Code Nr N. Cod.	Q.tà Q.ty Q.te M.ge C.ad	DENOMINAZIONE	NAME	DESIGNATION	BESHREIBUNG	DENOMINACION
	1	800075302	1	ALBERO SELETTORE CAMBIO	GEAR SELECTOR SHAFT	ARBRE SELECTEUR DE VITESSES	SCHALTWELLE	ARBOL SELECTOR CAMBIO
	2	8B0054139	1	VITE TE M6X1X15	SCREW TE M6X1X15	VIS TE M6X1X15	SCHRAUBE TE M6X1X15	TORNILLO TE M6X1X15
	3	M000P00578	1	MOLLA SALTARELLO FISSA MARCIA	SPRING, PAWL	RESSORT CLIQUET	FEDER, STRUMHAKEN	MUELLE SALTARELO
	4	800046225	1	MOLLA CAMBIO	SPRING, SHIFT RETURN	RESSORT RAPPEL LEVIER COMMANDE	RUECKHOLFEDER SCHALTHEBEL	MUELLE RETRACTOR PALANCA CAMBIO
	5	8A0031503	1	BOCCOLA	BUSH	DOUILLE	BUCHSE	BUJE
	6	800081681	1	PEDALE CAMBIO	PEDAL, GEAR CHANGE	PEDALE CHANGEMENT VITESSE	SCHALTPEDAL	PEDAL, CAMBIO VELOCIDADES
	7	60ND07336	1	VITE TE M6X1X22	SCREW TE M6X1X22	VIS TE M6X1X22	SCHRAUBE TE M6X1X22	TORNILLO TE M6X1X22
	8	62NA15767	1	RONDELLA ELASTICA	WASHER, SPRING	RONDELLE ELASTIQUE	FEDERSCHEIBE	ARANDELA ELASTICA
	9	8A0042700	1	ANELLO O-RING 2093 23,52X1,78 MM	O-RING 2093 23.52X1.78 MM	JOINT TORIQUE 2093 23,52X1,78 MM	O-RING 2093 23,52X1,78 MM	JUNTA TORICA 2093 23,52X1,78 MM
	10	800042676	1	PUNTALE FOLLE	POINT, NEUTRAL	CONTACTEUR POINT-MORT	BOLZEN LEERLAUF	PUNTO NEUTRO
	11	800042677	1	MOLLA PUNTALE	SPRING	RESSORT	FEDER	MUELLE
	12	800075291	1	ROCCHETTO DESMODROMICO	CAM-CHANGE DRUM	PIGNION DESMODROMIQUE	VERSCHIEBENOCKENRITZEL	PINION TAMBOR CAMBIO
	13	8000A6751	1	SEGNALETORE MARCE	SENSOR ASSY, GEAR POSITION	CAPTEUR POINT MORT	SENSOR LEERLAUF	SENSOR PUNTO MUERTO
	14	800071012	1	PIASTRINA	PLATE	PLAQUETTE	PLAETTCHEN	PLETINA
	15	Y00028327	2	VITE TSEI M6X1X14 CH4	SCREW TSEI M6X1X14 CH4	VIS TSEI M6X1X14 CH4	SCHRAUBE TSEI M6X1X14 CH4	TORNILLO TSEI M6X1X14 CH4
	16	Z00067997	2	VITE TEF M5X0,8X12 CH8	SCREW TEF M5X0.8X12 CH8	VIS TEF M5X0,8X12 CH8	SCHRAUBE TEF M5X0,8X12 CH8	TORNILLO TEF M5X0,8X12 CH8
	17	800071007	2	SALTARELLO ROCCHETTO	PAWL	CLIQUET	STRUMHAKEN	SALTARELO
	18	800071008	2	PUNTALE SALTARELLO	PUSH ROD	BARRE PRESSION	DRUCKSTANGE	VARILLA PRESION
	19	800071009	2	MOLLA PUNTALE	SPRING	RESSORT	FEDER	MUELLE
	20	800083126	1	PIASTRINA RITEGNO CUSCINETTO	RETAINER, BEARING	PLAQUE ARRET ROULEMENT	STOPPLATTE, LAGER	PLACA RETENCION COJINETE
	21	800082347	1	TAMBURO DESMODROMICO	CAM, GEAR SHIFT	TAMBOUR DESMODROMIQUE	VERSCHIEBENOCKEN	TAMBOR CAMBIO
	22	800038520	1	RULLO 4X8	ROLLER 4X8	ROULEAU 4X8	ROLLE 4X8	RODILLO 4X8
	23	800085395	1	CUSCINETTO A SFERE 25X42X9	BEARING, BALL 25X42X9	ROULEMENT A BILLES 25X42X9	KUGELLAGER 25X42X9	COJINETE DE BOLAS 25X42X9
	24	8A0097739	1	ROCCHETTO DESMODROMICO	CAM-CHANGE DRUM	PIGNION DESMODROMIQUE	VERSCHIEBENOCKENRITZEL	PINION TAMBOR CAMBIO
	25	800071011	1	VITE	SCREW	VIS	SCHRAUBE	TORNILLO
	26	Z00056377	1	RONDELLA 16X8,3X1	WASHER 16X8.3X1	RONDELLE 16X8,3X1	SCHIEBE 16X8,3X1	ARANDELA 16X8,3X1
	27	800071158	1	FORCHETTA SELETTORE CAMBIO 3A-4A	FORK, GEAR SHIFTING 3TH-4TH	FOURCHETTE SELECTEUR 3EME-4EME	SCHALTGABEL 3.-4. GANG	HORQUILLA SELECTOR 3ERA-4A
	28	800071159	1	FORCHETTA SELETTORE CAMBIO 1A-5A	FORK, GEAR SHIFTING 1ST-5TH	FOURCHETTE SELECTEUR 1ERE-5EME	SCHALTGABEL 1.-5. GANG	HORQUILLA SELECTOR 1ERA-5A
	29	800071160	1	FORCHETTA SELETTORE CAMBIO 2A-6A	FORK, GEAR SHIFTING 2ND-6TH	FOURCHE ENGRENEMENT 2EME-6EME	SCHALTGABEL 2.-6.	HORQUILLA SELECTOR 2NDA-6A
	30	800035876	1	ASSE FORCHETTA SELETTORE CAMBIO 85MM	AXLE, GEAR SHIFT FORK 85MM	AXE FOURCHETTE CHANGEMENT 85MM	ACHSE, SCHALTGABEL 85MM	EJE, HORQUILLA CAMBIO 85MM
	31	8B0035876	1	ASSE FORCHETTA SELETTORE CAMBIO 93,5MM	AXLE, GEAR SHIFT FORK 93.5MM	AXE FOURCHETTE CHANGEMENT 93,5MM	ACHSE, SCHALTGABEL 93,5MM	EJE, HORQUILLA CAMBIO 93,5MM
	32	800054136	1	SALTARELLO FISSA MARCE	STOPPER LEVER	CLIQUET COMPLETE	SPERRKLINKE	TRINQUETE FIJO MARCHAS

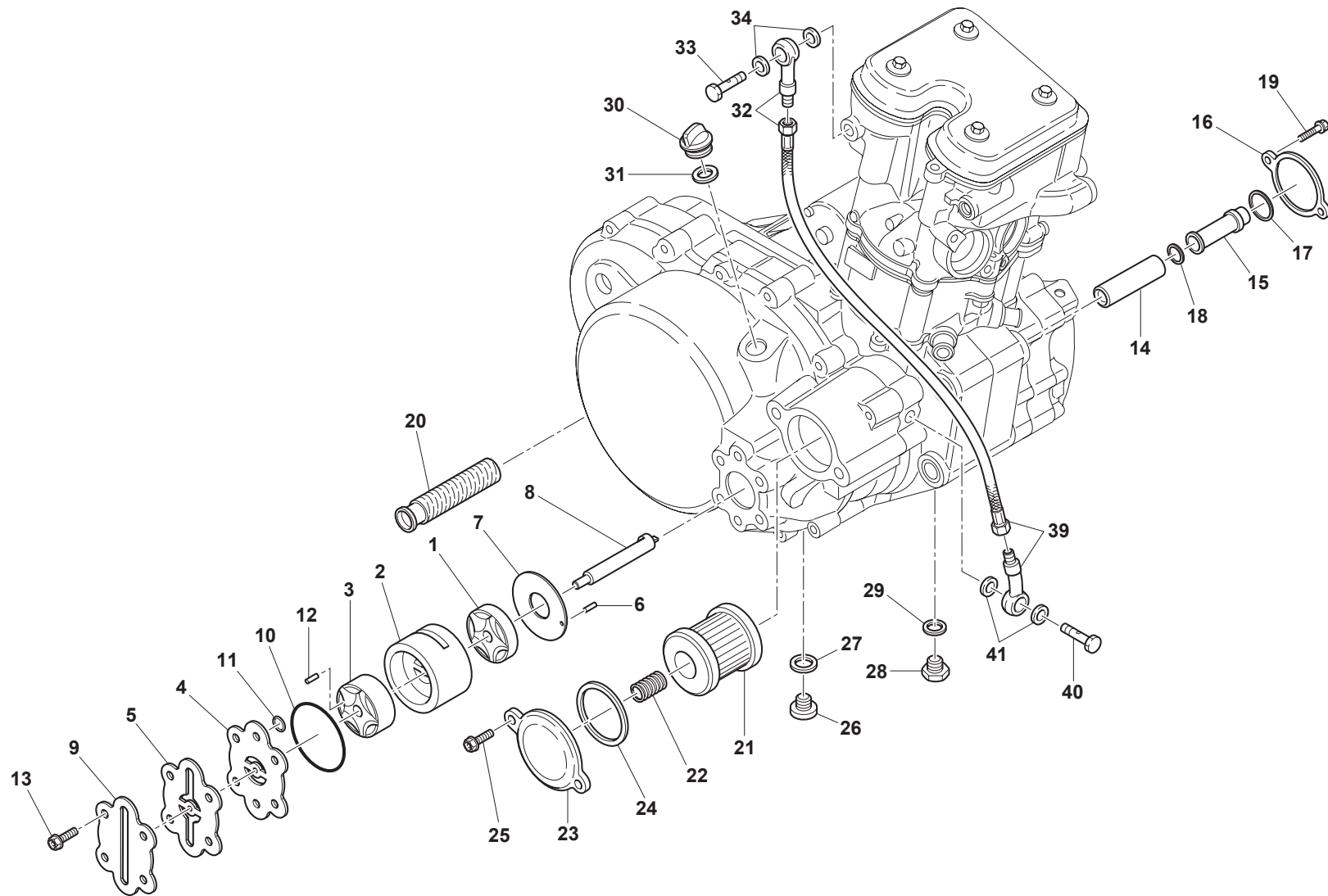



RS-SM 650R/2016

LUBRIFICAZIONE - LUBRIFICATION GRAISSAGE - SCHMIERUNG LUBRICACION

TAVOLA
DRAWING
TABLE
BILD
TABLA

11

Note Notes Notes Marke Notas	Pos. No. N. Index Pos.	N. Cod. Code No. Nr. Code Code Nr N. Cod.	Q.tà Q.ty Q.te M.ge C.ad	DENOMINAZIONE	NAME	DESIGNATION	BESHREIBUNG	DENOMINACION
	1	8000H4001	1	ROTORE RITORNO POMPA OLIO	ROTOR, OIL PUMP SCAVENGE	ROTOR RETOUR POMPE A HUILE	ROTOR, OELPUMPE RUECKLAUF	ROTOR RETORNO BOMBA ACEITE
	2	8000H4002	1	CORPO POMPA OLIO	HOUSING, OIL PUMP	CORPS POMPE A HUILE	OELPUMPEGEHAEUSE	CUERPO BOMBA ACEITE
	3	800082948	1	TROCOIDE ASPIRAZIONE OLIO	OIL SUCTION ROTOR	ROTOR ASPIRATEUR HUILE	OELSAUGROTOR	ROTOR ADMISION ACEITE
	4	800084821	1	COPERCHIO INTERMEDIO POMPA	COVER	COUVERCLE	DECKEL	TAPA
	5	8000A1374	1	FLANGIA CUSCINETTO	HOUSING, BEARING	BOITE PORTE ROULEMENT	GEHAUSE, LAGERHALTERUNG	CAJA SOPORTE COJNETE
	6	8B0047773	1	RULLINO DI RIFERIMENTO	ROLLER	ROULEAU	ROLLE	RODILLO
	7	800084819	1	DISTANZIALE INTERNO POMPA	INNER SPACER	ENTRETOISE INTERIEUR	INNEREABSTANDHALTER	DISTANCIADOR INTERIOR
	8	800084818	1	ALBERO POMPA OLIO	SHAFT, OIL PUMP	ARBRE POMPE A HUILE	WELLE, OELPUMPE	ARBOL, BOMBA ACEITE
	9	80C075630	1	COPERCHIO POMPA OLIO	COVER OIL PUMP	COUVERCLE POMPE HUILE	OELPUMPENDECKEL	CUBIERTA BOMBA ACEITE
	10	800027073	1	ANELLO O-RING 3156 39,34X2,6	O-RING 3156 39,34X2,6	JOINT TORIQUE 3156 39,34X2,6	O-RING 3156 39,34X2,6	JUNTA TORICA 3156 39,34X2,6
	11	8A0023108	2	ANELLO O-RING 2037 1,78X9,25	O RING 2037 1.78X9.25	JOINT TORIQUE 2037 1,78X9,25	O-RING 2037 1,78X9,25	JUNTA TORICA 2037 1,78X9,25
	12	8A0047773	2	RULLINO	ROLLER	ROULEAU	ROLLE	RODILLO
	13	Z00062728	4	VITE TEF M6X1X20 CH8	SCREW TEF M6X1X20 CH8	VIS TEF M6X1X20 CH8	SCHRAUBE TEF M6X1X20 CH8	TORNILLO TEF M6X1X20 CH8
	14	800072426	1	FILTRO OLIO ESTERNO	OIL FILTER, OUTER	FILTRE A HUILE EXTERIEUR	OELFILTER, AUSSER	FILTRO ACEITE EXTERIOR
	15	800072427	1	FILTRO OLIO INTERNO	OIL FILTER, INNER	FILTRE A HUILE INTERIEUR	OELFILTER, INNEN	FILTRO ACEITE INTERIOR
	16	800072425	1	COPERCHIO FILTRO OLIO	COVER, OIL ELEMENT	COUVERCLE FILTRE A HUILE	DECKEL, OELFILTER	CUBIERTA FILTRO ACEITE
	17	800034609	1	ANELLO O-RING 3087 22X2,62	O-RING 3087 22X2.62	JOINT TORIQUE 3087 22X2,62	O-RING 3087 22X2,62	JUNTA TORICA 3087 22X2,62
	18	800026884	1	ANELLO O-RING 3062 15,54X2,62	O-RING 3062 15.54X2.62	JOINT TORIQUE 3062 15,54X2,62	O-RING 3062 15,54X2,62	JUNTA TORICA 3062 15,54X2,62
	19	Z00067997	2	VITE TEF M5X0,8X12 CH8	SCREW TEF M5X0,8X12 CH8	VIS TEF M5X0,8X12 CH8	SCHRAUBE TEF M5X0,8X12 CH8	TORNILLO TEF M5X0,8X12 CH8
	20	800074716	1	FILTRO OLIO ASPIRAZIONE	STRAINER, OIL	CREPINE HUILE	OELNETZ	REDECILLA ACEITE
	21	8000B0593	1	FILTRO OLIO	FILTER, OIL	FILTRE A HUILE	OELFILTER	FILTRO ACEITE
	22	800085385	1	MOLLA FILTRO OLIO	SPRING, OIL FILTER	RESSORT FILTRE A HUILE	FEDER, OELFILTER	RESORTE, FILTRO ACEITE
	23	80C078988	1	COPERCHIO FILTRO OLIO	COVER, OIL ELEMENT	COUVERCLE FILTRE A HUILE	DECKEL, OELFILTER	CUBIERTA FILTRO ACEITE
	24	8A0028553	1	ANELLO O-RING 3200 2,62X50,47	O-RING 3200	JOINT TORIQUE 3200	O-RING 3200	JUNTA TORICA 3200
	25	Z00062728	2	VITE TEF M6X1X20 CH8	SCREW TEF M6X1X20 CH8	VIS TEF M6X1X20 CH8	SCHRAUBE TEF M6X1X20 CH8	TORNILLO TEF M6X1X20 CH8
	26	800096747	1	TAPPO DRENAGGIO OLIO M22X1,5	OIL DRAIN PLUG M22X1.5	BOUCHON VIDANGE HUILE M22X1,5	OELABLASSVERSCHLUSS M22X1,5	TAPON PURGA ACEITE M22X1,5
	27	62N015682	1	RONDELLA GUARNIZIONE 22,3X28X1	WASHER 22.3X28X1	RONDELLE 22,3X28X1	SCHEIBE 22,3X28X1	ARANDELA 22,3X28X1
	28	800075415	1	TAPPO DRENAGGIO OLIO M14X1,25	OIL DRAIN PLUG M14X1,25	BOUCHON VIDANGE HUILE M14X1,25	OELABLASSVERSCHLUSS M14X1,25	TAPON PURGA ACEITE M14X1,25
	29	62N015678	1	RONDELLA IN ALLUMINIO 21X14,3X1,2	WASHER, ALUMINIUM 21X14.3X1.2	RONDELLE EN ALUMINIUM 21X14,3X1,2	ALUMINIUM SCHEIBE 21X14,3X1,2	ARANDELA ALUMINIO 21X14,3X1,2
	30	800049032	1	TAPPO ALIMENTAZIONE OLIO	CAP, OIL FILLER	BOUCHON REMPLISSEMENT HUILE	STOEPSSEL OELEINFUELL	TAPON INTRUDUCCION ACEITE
	31	800019789	1	ANELLO O-RING 2081 20,35X1,78	O-RING 2081 20.35X1.78	JOINT TORIQUE 2081 20,35X1,78	O-RING 2081 20,35X1,78	JUNTA TORICA 2081 20,35X1,78
	32	8000H1763	1	TUBO MANDATA OLIO	HOSE, OIL DELIVERY	TUYAU REFOULEMENT HUILE	OELZUFUHRLEITUNG	TUBO ALIMENTACION ACEITE
	33	8A00A0574	2	VITE FORATA	BANJO BOLT	VIS CREUSE	HOHLSCHRAUBE	TORNILLO TALADRADO

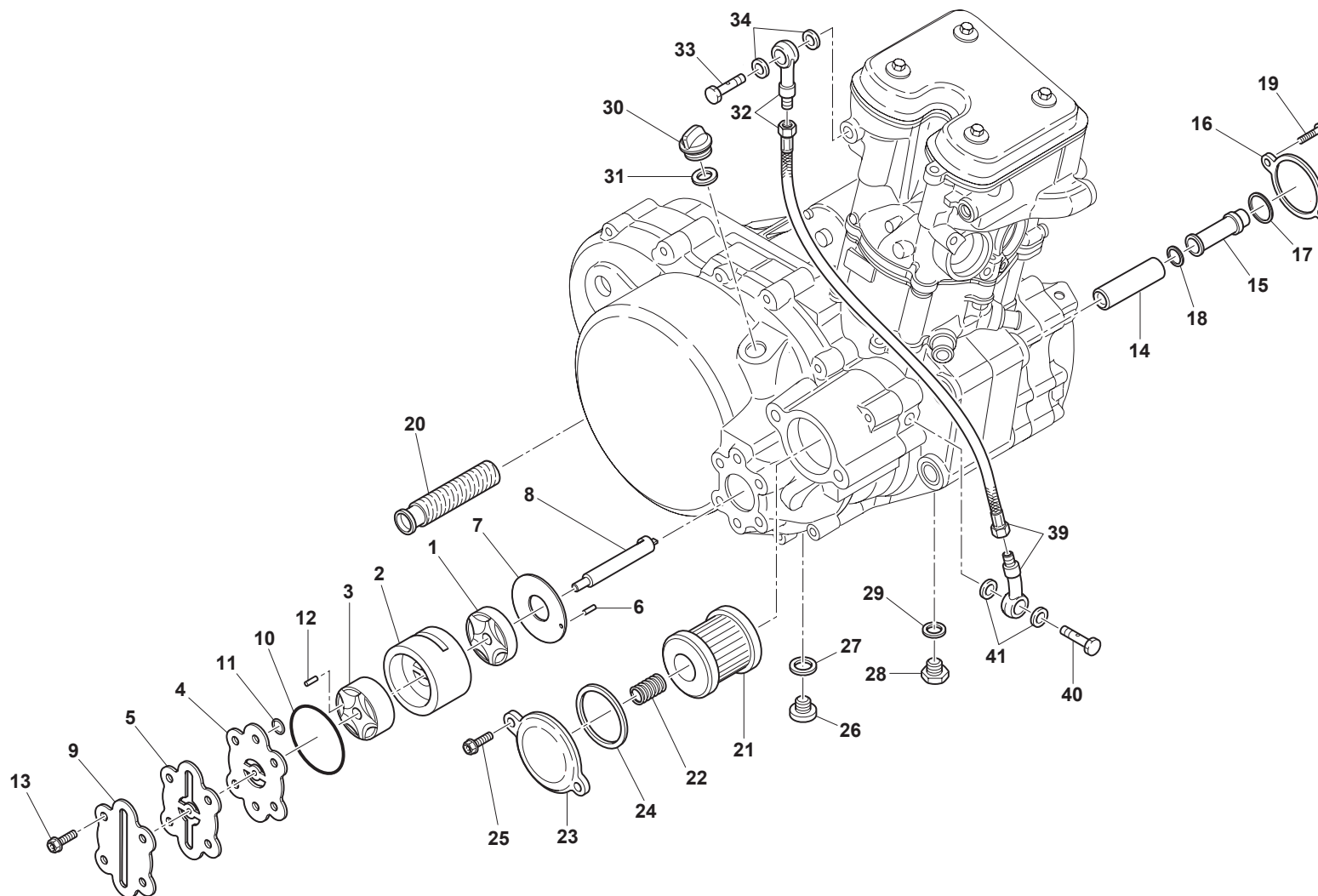

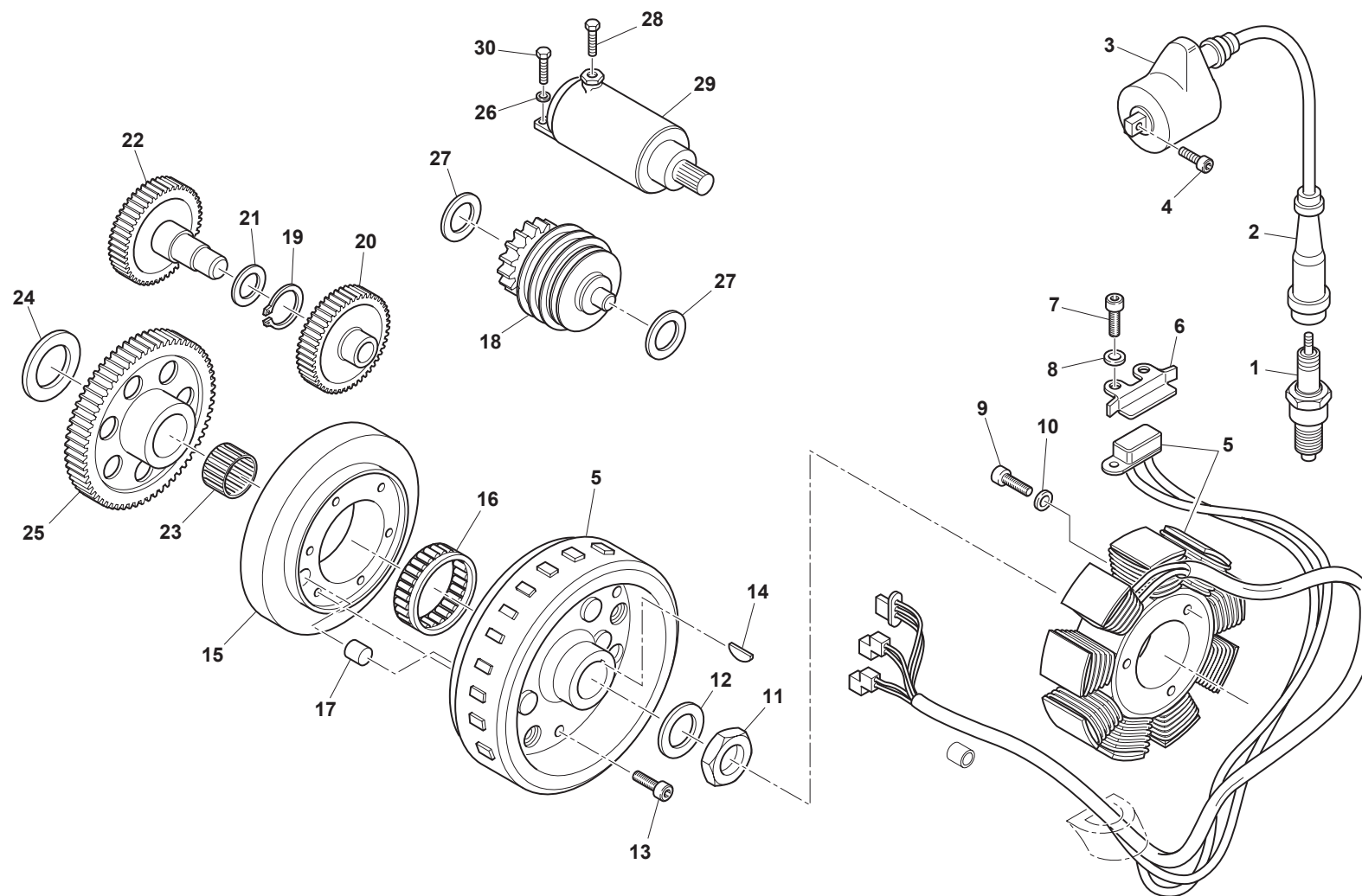

**RS-SM 650R/2016**

PARTE ELETTRICA, IMPIANTO ELETTRICO - IGNITION SYSTEM, ELECTRIC SYSTEM
PARTIES ELECTRIQUE, INSTALLATION ELECTRIQUE- ELEKTRISCHE TEILE, ELEKTRISCHE ANLAGE
PARTE ELECTRICA, INSTALACION ELECTRICA

TAVOLA
DRAWING
TABLE
BILD
TABLA

12

Note Notes Notas	Pos. No. Index Pos.	N. Cod. Code No. Nr. Code Code Nr N. Cod.	Q.tà Q.ty M.ge C.ad	DENOMINAZIONE	NAME	DESIGNATION	BESHREIBUNG	DENOMINACION
	1	8000A0573	1	CANDELA	PLUG, SPARK	BOUGIE	ZUENDKERZE	BUJIA
	2	8000A6740	1	PIPETTA CANDELA	CAP, SPARK PLUG	ANTIPARASITE	ZUENDKERZENSTECKER	CAPUCHON PORTA BUJIA
	3	8000H0277	1	BOBINA ACCENSIONE	COIL, IGNITION	BOBINE ALLUMAGE	ZUENDSPULE	BOBINA ENCENDIDO
	4	Z00062728	2	VITE TEF M6X1X20 CH8	SCREW TEF M6X1X20 CH8	VIS TEF M6X1X20 CH8	SCHRAUBE TEF M6X1X20 CH8	TORNILLO TEF M6X1X20 CH8
	5	8000A6767	1	GENERATORE	GENERATOR	GENERATEUR	STROMGENERATOR	GENERADOR
	6	8000H3841	1	FERMACAVO	CLAMP, WIRE	COLLIER, CORDON	KABELKLEMME	GRAMPA CORDON
	7	60ND02461	2	VITE TCEI M4X0,7X10	SCREW TCEI M4X0,7X10	VIS TCEI M4X0,7X10	SCHRAUBE TCEI M4X0,7X10	TORNILLO TCEI M4X0,7X10
	8	62ND15534	2	RONDELLA ELASTICA 7,3X4,3X0,9	SPRING WASHER 7.3X4.3X0.9	RONDELLE ELASTIQUE 7,3X4,3X0,9	FEDERSCHEIBE 7,3X4,3X0,9	ARANDELA ELASTICA 7,3X4,3X0,9
	9	60ND02511	3	VITE TCEI M6X1X30	SCREW TCEI M6X1X30	VIS TCEI M6X1X30	SCHRAUBE TCEI M6X1X30	TORNILLO TCEI M6X1X30
	10	62NA15767	3	RONDELLA 11X6,4X0,5	WASHER 11X6.4X0.5	RONDELLE 11X6,4X0,5	SCHEIBE 11X6,4X0,5	ARANDELA 11X6,4X0,5
	11	8000H3679	1	DADO	NUT	ECROU	MUTTER	TUERCA
	12	8000H3680	1	RONDELLA	WASHER	RONDELLE	SCHEIBE	ARANDELA
	13	8A0078647	6	VITE	SCREW	VIS	SCHRAUBE	TORNILLO
	14	65N121007	1	CHIAVETTA	KEY, WOODRUFF	CLAVETTE WOODRUFF	KEIL WOODRUFF	CHAVETA WOODRUFF
	15	8A0084828	1	MASSA SUPPLEMENTARE	ADDITIONAL WEIGHT	MASSE SUPPLEMENTAIRE	MASSE ZUSAETLICH	MASA ADICIONAL
	16	800083136	1	RUOTA LIBERA	CLUTCH, ONE WAY	ROUE LIBRE	EINWEGKUPPLUNG	EMBRAGUE, UNA VIA
	17	800086051	1	SPINA RIFERIMENTO 8X10	PIN DOWEL 8X10	GOUJON, ASSEMBLAGE 8X10	BEZUGSSTIFT 8X10	PASADOR ESPIGA REFERENCIA 8X10
	18	8000A5015	1	LIMITATORE DI COPPIA Z17/52	TORQUE LIMITER Z17/52	LIMITEUR DE COUPLE Z17/52	DREHMOMENTBEGRENZER Z17/52	LIMITADOR DE PAR Z17/52
	19	66ND21196	1	ANELLO SEEGER 13MM	CIRCLIP 13MM	CIRCLIP 13MM	SPRENGRING 13MM	ANILLO SEEGER 13MM
	20	800084831	1	INGRANAGGIO RINVIO Z27	IDLE GEAR T27	PIGNON INTERMEDIAIRE D27	FREILAUFRAD Z27	ENGRANAJE INTERMEDIO D27
	21	8F0009408	1	RONDELLA 22X14,5X1	WASHER 22X14.5X1	RONDELLE 22X14,5X1	SCHEIBE 22X14,5X1	ARANDELA 22X14,5X1
	22	800089012	1	INGRANAGGIO RINVIO Z20	IDLE GEAR T22	PIGNON INTERMEDIAIRE D22	FREILAUFRAD Z22	ENGRANAJE INTERMEDIO D22
	23	800084597	1	GABBIA A RULLI 28X34X20	BEARING, NEEDLE 28X34X20	ROULEMENT A AIGUILLES 28X34X20	NADELLAGER 28X34X20	COJINETE DE AGUJAS 28X34X20
	24	8A0084473	1	RONDELLA RASAMENTO	WASHER, THRUST	RONDELLE BUTEE	DISTANZSCHEIBE	ARANDELA SEPARACION
	25	800089011	1	INGRANAGGIO RUOTA LIBERA Z62	GEAR, FREE-WHEEL T62	PIGNON DE ROUE LIBRE D62	ZAHNRAD FREILAUFRAD Z62	ENGRANAJE RUEDA LIBRE D62
	26	800048591	2	RONDELLA ELASTICA 10X6,4X0,5	SPRING WASHER 10X6.4X0.5	RONDELLE ELASTIQUE 10X6,4X0,5	FEDERSCHEIBE 10X6,4X0,5	ARANDELA ELASTICA 10X6,4X0,5
	27	8000A1017	2	BOCCOLA	BUSH	DOUILLE	BUCHSE	BUJE
	28	Z00062729	1	VITE TEF M6X1X25 CH8	SCREW TEF M6X1X25 CH8	VIS TEF M6X1X25 CH8	SCHRAUBE TEF M6X1X25 CH8	TORNILLO TEF M6X1X25 CH8
	29	8000H1772	1	MOTORINO AVVIAMENTO	STARTING MOTOR	DEMARREUR ELECTRIQUE	ANLASSERMOTOR	MOTOR ARRANQUE
	30	Z00062728	1	VITE TEF M6X1X20 CH8	SCREW TEF M6X1X20 CH8	VIS TEF M6X1X20 CH8	SCHRAUBE TEF M6X1X20 CH8	TORNILLO TEF M6X1X20 CH8

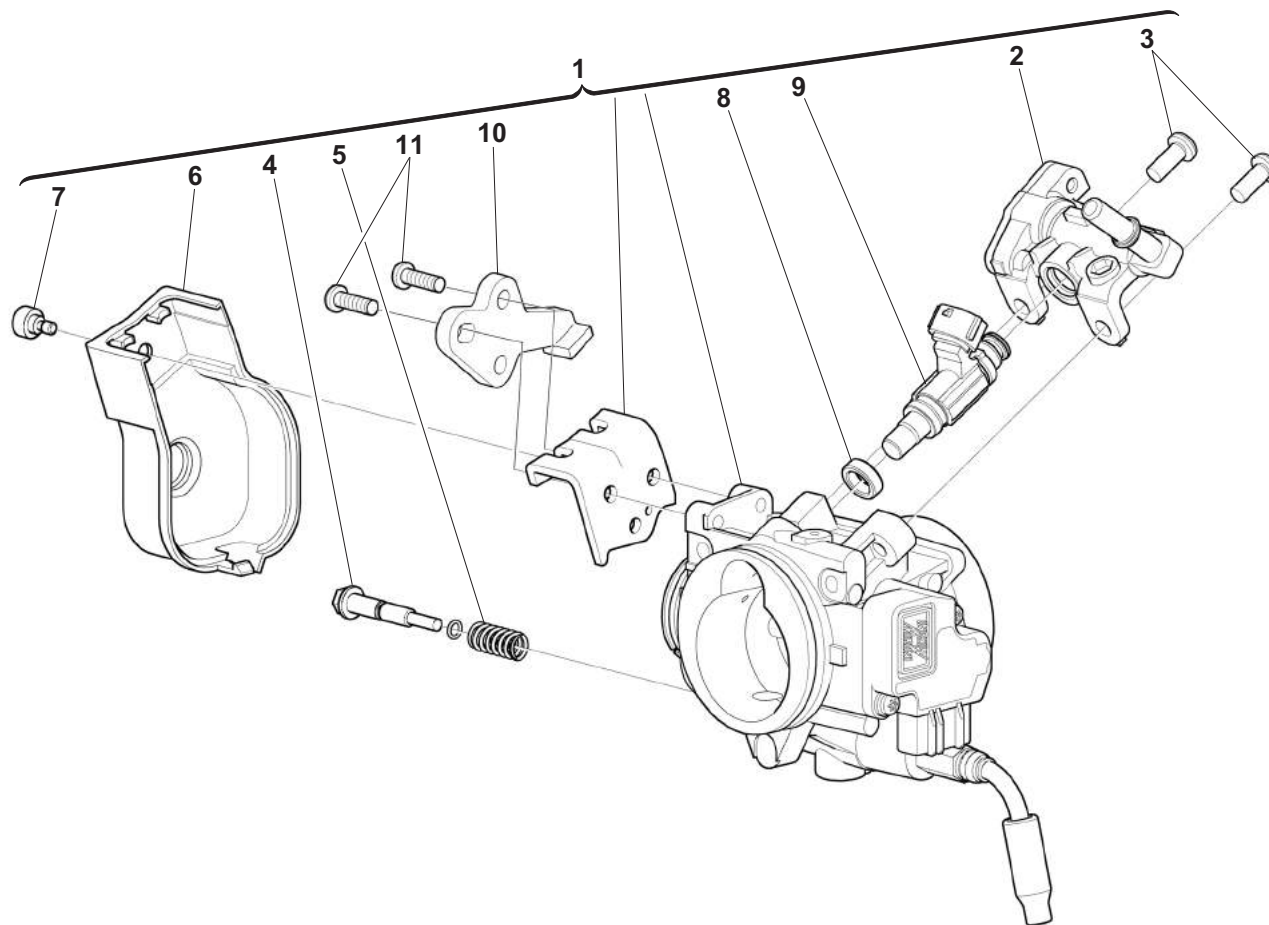

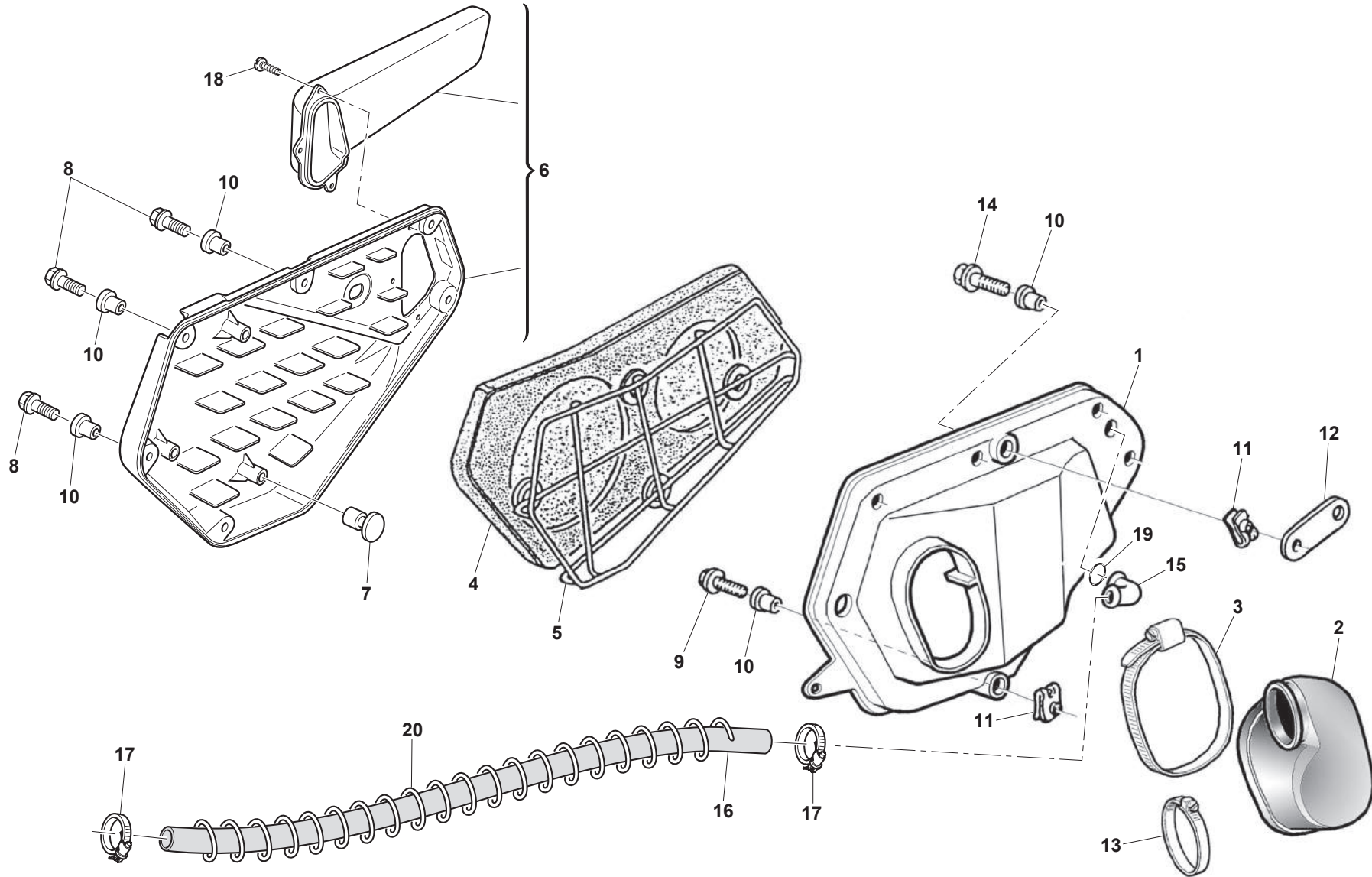

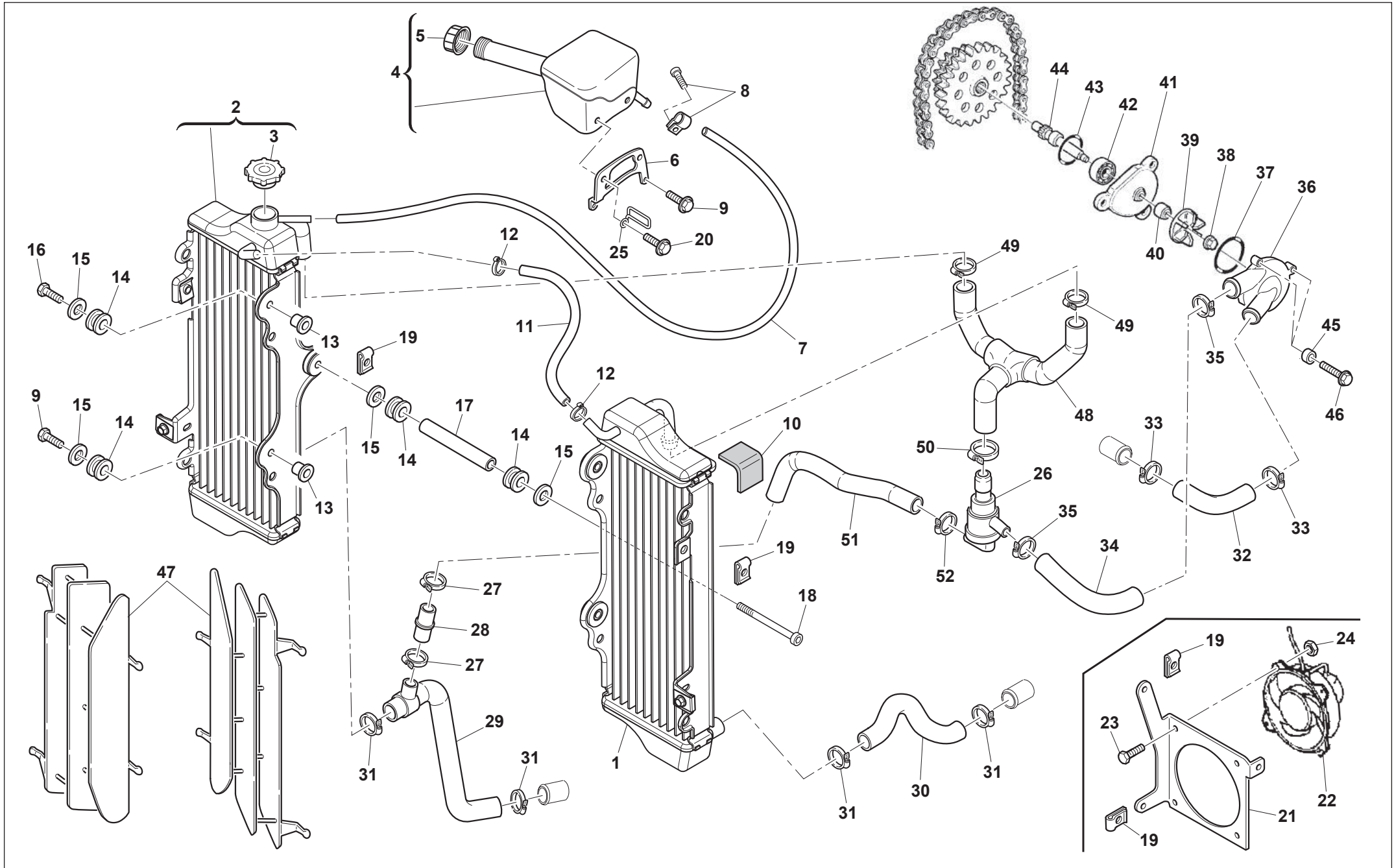

**RS-SM 650R/2016**

**IMPIANTO DI RAFFREDDAMENTO - COOLING SYSTEM
 INSTALLATION DE REFRIGERATION - SCHMIERUNGSSYSTEM
 EQUIPO DE ENFRIAMIENTO**

TAVOLA
 DRAWING
 TABLE
 BILD
 TABLA

15

Note Notes Notes Marke Notas	Pos. No. N. Index Pos.	N. Cod. Code No. Nr. Code Code Nr N. Cod.	Q.tà Q.ty Q.te M.ge C.ad	DENOMINAZIONE	NAME	DESIGNATION	BESHREIBUNG	DENOMINACION
	1	F000P00022	1	RADIATORE ACQUA SINISTRO	RADIATOR, WATER, LH	RADIATEUR EAU GAUCHE	WASSERKUEHLER LINKS	RADIADOR AGUA IZQUERDO
	2	F000P00023	1	RADIATORE ACQUA DESTRO	RADIATOR, WATER, RH	RADIATEUR EAU DROIT	WASSERKUEHLER RECHTS	RADIADOR AGUA DERECHO
	3	F000P00717	1	TAPPO RADIATORE ACQUA	CAP, RADIATOR	BOUCHON RADIATEUR	KUEHLERPROPFEN	TAPON RADIADOR
	4	8000H1041	1	VASO ESPANSIONE	TANK, WATER RESERVOIR	VASE EXPANSION	AUSDEHNGEFAESS	VASO EXPANSION
	5	800040427	1	TAPPO VASO ESPANSIONE	CAP, WATER RESERVOIR TANK	BOUCHON VASE EXPANSION	PFROPFEN, AUSDEHNGEFAESS	TAPON VASO EXPANSION
	6	8000H0971	1	SUPPORTO VASO ESPANSIONE	BRACKET, WATER TANK	SUPPORT RESERVOIR EAU	WASSERTANKHALTERUNG	SOPORTE DEPOSITO AGUA
	7	8000A1281	1	TUBO	HOSE	TUYAU	SCHLAUCH	MANGUERA
	8	8B0091687	1	FASCETTA STRINGITUBO INOX D10	CLAMP, HOSE	COLLIER A VIS	SCHRAUBENSCHELLE	ABRAZADERA CON ROSCA
	9	Z00062725	6	VITE TEF M6X1,00X10 CH8	SCREW TEF M6X1.00X10 CH8	VIS TEF M6X1,00X10 CH8	SCHRAUBE TEF M6X1,00X10 CH8	TORNILLO TEF M6X1,00X10 CH8
	10	8A0087072	2	TAMPONE ADESIVO	GROMMET ADHESIVE	CAOUTCHOUC ADHESIF	KLEBERGUMMI	GOMA ADHESIVA
	11	8000H1298	1	TUBO RACCORDO RADIATORI	HOSE JOINT, RADIATOR	TUYAU RACCORD RADIATEUR	KUEHLERVERBINDUNGS SCHLAUCH	TUBO EMPALME RADIADOR
	12	8000H1981	2	FASCETTA 13X5 MM	CLAMP 13X5 MM	COLLIER 13X5 MM	SCHELLE 13X5 MM	ABRAZADERA 13X5 MM
	13	8G0059802	4	BOCCOLA	BUSH	DOUILLE	BUCHSE	BUJE
	14	F000P00025	6	SILENTBLOCK RADIATORE	RUBBER, RADIATOR MOUNTING	CAOUTCHOUC MONTAGE RADIATEUR	SCHWINGUNGSDAEMPFER, KUEHLER	CASQUILLO ELASTICO RADIADOR
	15	Z00059801	5	RONDELLA 22X6,5X1	WASHER 22X6.5X1	RONDELLE 22X6,5X1	SCHEIBE 22X6,5X1	ARANDELA 22X6,5X1
	16	Z00062728	2	VITE TEF M6X1X20 CH8	SCREW TEF M6X1X20 CH8	VIS TEF M6X1X20 CH8	SCHRAUBE TEF M6X1X20 CH8	TORNILLO TEF M6X1X20 CH8
	17	800066858	1	DISTANZIALE 10X7X64	SPACER 10X7X64	ENTRETOISE 10X7X64	ABSTANDHALTER 10X7X64	DISTANCIADOR 10X7X64
	18	60ND02525	1	VITE TCEI M6X1X100	SCREW TCEI M6X1X100	VIS TCEI M6X1X100	SCHRAUBE TCEI M6X1X100	TORNILLO TCEI M6X1X100
	19	Z00046893	3	DADO ELASTICO M6X1	CLIP NUT M6X1	JONC M6X1	KLEMME M6X1	PREASIENTO M6X1
	20	ZS0067545	2	VITE TEF M6X1,00X10 CH8	SCREW TEF M6X1.00X10 CH8	VIS TEF M6X1,00X10 CH8	SCHRAUBE TEF M6X1,00X10 CH8	TORNILLO TEF M6X1,00X10 CH8
	21	8000H0911	1	SUPPORTO ELETTOVENTOLA	BRACKET ELECTRIC FAN	SUPPORT ELECTROVENTILATEUR	HALTER ELEKTROLUEFTER	SOPORTE VENTILADOR ELECTRICO
	22	8000A7715	1	ELETTOVENTOLA	BLOWER ASSY	ELECTRO-VENTILATEUR	ELEKTROLUEFTERRAD	ELECTROVENTILADOR
	23	60ND01030	4	VITE TE M4X0,7X25	SCREW TE M4X0.7X25	VIS TE M4X0,7X25	SCHRAUBE TE M4X0,7X25	TORNILLO TE M4X0,7X25
	24	Z00040717	4	DADO FLANGIATO M4X0,7	NUT FLANGE M4X0.7	ECROU BRIDE M4X0,7	GEFLANSCHTE MUTTER M4X0,7	TUERCA CON REBORDE M4X0,7
	25	800086951	1	PASSACAVO	GUIDE, CABLE	PASSE-CABLE	KABELDURCHGANG	PASACABLES
	26	8B0075984	1	TERMOSTATO	THERMOSTAT	THERMOSTAT	THERMOSTAT	TERMOSTATO
	27	8000H1981	2	FASCETTA HOP 8-10/18 MM	CLAMP HOP 8-10/18 MM	COLLIER HOP 8-10/18 MM	SCHELLE HOP 8-10/18 MM	ABRAZADERA HOP 8-10/18 MM
	28	800094680	1	RACCORDO TUBO	JOINT, HOSE	RACCORD TUYAU	ANSCHLUSS, SCHLAUCH	RACOR MANGUERA
	29	8000H1205	1	TUBO ACQUA DESTRO	HOSE, WATER RH	TUYAU EAU DROIT	SCHLAUCH, WASSER, RECHTS	MANGUERA AGUA DERECHO
	30	8000H1206	1	TUBO ACQUA RADIATORE-POMPA	HOSE-COOLING, RADIATOR-PUMP	TUYAU EAU RADIATEUR-POMPE	SCHLAUCH, WASSER KUEHLER-PUMPE	MANGUERA AGUA BOMBA/RADIADOR
	31	8A0099475	4	FASCETTA HOP 8-12/22 MM	CLAMP HOP 8-12/22 MM	COLLIER HOP 8-12/22 MM	SCHELLE HOP 8-12/22 MM	ABRAZADERA HOP 8-12/22 MM
	32	8A0099708	1	TUBO ACQUA TESTA POMPA	HOSE-COOLING CYLINDER HEAD PUMP	TUYAU EAU COULASSE POMPE	WASSERLEITUNG ZYLINDERKOPF PUMPE	MANGUERA AGUA CULATA BOMBA
	33	8B0099475	2	FASCETTA HOP 8-16/27 MM	CLAMP HOP 8-16/27 MM	COLLIER HOP 8-16/27 MM	SCHELLE HOP 8-16/27 MM	ABRAZADERA HOP 8-16/27 MM

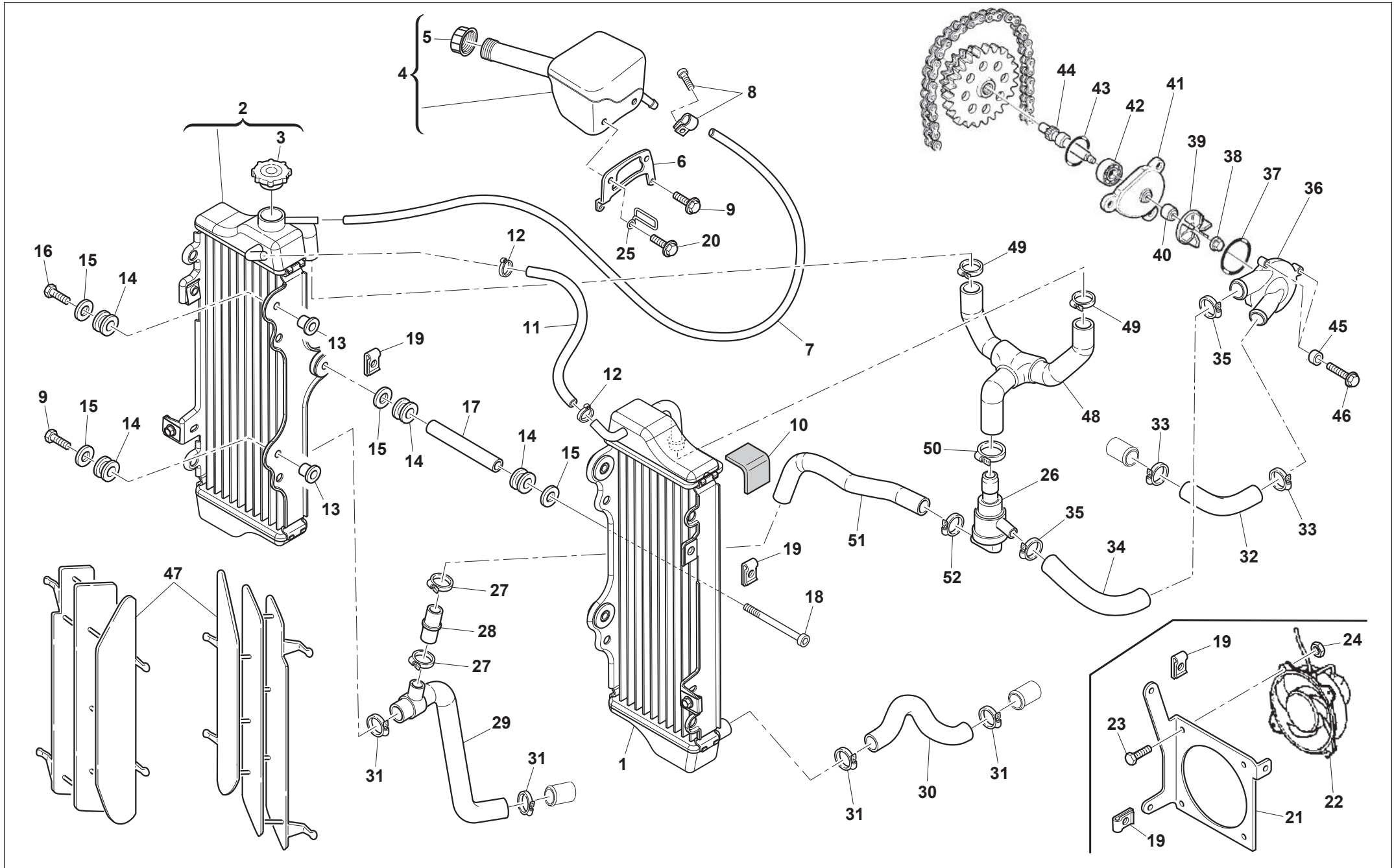

**RS-SM 650R/2016**

IMPIANTO DI RAFFREDDAMENTO - COOLING SYSTEM
INSTALLATION DE REFRIGERATION - SCHMIERUNGSSYSTEM
EQUIPO DE ENFRIAMIENTO

TAVOLA
DRAWING
TABLE
BILD
TABLA

15

Note Notes Notas	Pos. No. Index Pos.	N. Cod. Code No. Nr. Code Code Nr N. Cod.	Q.tà Q.ty Q.te M.ge C.ad	DENOMINAZIONE	NAME	DESIGNATION	BESHREIBUNG	DENOMINACION
	34	8000H1529	1	TUBO ACQUA TERMOSTATO POMPA	HOSE-COOLING THERMOSTAT PUMP	TUYAU EAU THERMOSTAT POMPE	SCHLAUCH, WASSER THERMOSTAT PUMPE	MANGUERA AGUA TERMOSTATO BOMBA
	35	8B0099475	2	FASCETTA 8-16/27	CLAMP 8-16/27	COLLIER 8-16/27	SHELLE 8-16/27	ABRAZADERA 8-16/27
	36	8000H1958	1	CORPO POMPA ACQUA	CASE, WATER PUMP	CORPS POMPE A EAU	GEHAUSE, WASSERPUMPE	CAJA BOMBA AGUA
	37	800027122	1	ANELLO O-RING 3237 60X2,62	O-RING 3237 60X2,62	JOINT TORIQUE 3237 60X2,62	O-RING 3237 60X2,62	JUNTA TORICA 3237 60X2,62
	38	Z00056443	1	DADO AUTOBLOCCANTE M5X0,8 H6	NUT, SELF LOCKING M5X0,8 H6	ECROU AUTOBLOQUANT M5X0,8 H6	SELBSTSPERRENDE MUTTER M5X0,8 H6	TUERCA AUTOBLOQUEANTE M5X0,8 H6
	39	8000H1462	1	GIRANTE POMPA ACQUA	IMPELLER, WATER PUMP	TURBINE POMPE A EAU	WASSERPUMPE LAUFSCHWUNGRAD	ROTOR BOMBA AGUA
	40	800053339	1	PARAOLIO 8X16X10	OIL SEAL 8X16X10	BAGUE D'ETANCHEITE 8X16X10	WELLENDICHRING 8X16X10	RETEN DE ACEITE 8X16X10
	41	800091565	1	FLANGIA SUPPORTO POMPA ACQUA	FLANGE, WATER PUMP	BRIDE POMPE A EAU	FLANSCH, WASSERPUMPE	BRIDA BOMBA AGUA
	42	800034317	1	CUSCINETTO A SFERE 12X28X8	BEARING, BALL 12X28X8	ROULEMENT A BILLES 12X28X8	KUGELLAGER 12X28X8	COJINETE DE BOLAS 12X28X8
	43	800040007	1	ANELLO O-RING 2125	O-RING 2125	JOINT TORIQUE 2125	O-RING 2125	JUNTA TORICA 2125
	44	8000A4789	1	ALBERO POMPA ACQUA	SHAFT, WATER PUMP	ARBRE POMPE A EAU	WELLE, WASSERPUMPE	ARBOL, BOMBA AGUA
	45	161795501	2	BOCCOLA 8X6,4X6	BUSH 8X6,4X6	DOUILLE 8X6,4X6	BUCHSE 8X6,4X6	CASQUILLO 8X6,4X6
	46	Z00062730	3	VITE TE M6X1X30 CH8	SCREW TE M6X1X30 CH8	VIS TE M6X1X30 CH8	SCHRAUBE TE M6X1X30 CH8	TORNILLO TE M6X1X30 CH8
	47	80A0A0872	2	GRIGLIA RADIATORE	LOUVER, RADIATOR	GRILLE RADIATEUR	KHUELERGRILL	REJILLA RADIADOR
	48	8000H1202	1	TUBO ACQUA	HOSE, WATER	TUYAU EAU	SCHLAUCH, WASSER	MANGUERA AGUA
	49	8A0099475	2	FASCETTA HOP 8-12/22 MM	CLAMP HOP 8-12/22 MM	COLLIER HOP 8-12/22 MM	SHELLE HOP 8-12/22 MM	ABRAZADERA HOP 8-12/22 MM
	50	8B0099475	2	FASCETTA HOP 8-16/27 MM	CLAMP HOP 8-16/27 MM	COLLIER HOP 8-16/27 MM	SHELLE HOP 8-16/27 MM	ABRAZADERA HOP 8-16/27 MM
	51	8000H1203	1	TUBO BYPASS	HOSE, WATER BYPASS	TUYAU BY-PASS	SCHLAUCH, BY-PASS	TUBO BY-PASS
	52	8A0099475	1	FASCETTA HOP 8-10/18 MM	CLAMP HOP 8-10/18 MM	COLLIER HOP 8-10/18 MM	SHELLE HOP 8-10/18 MM	ABRAZADERA HOP 8-10/18 MM

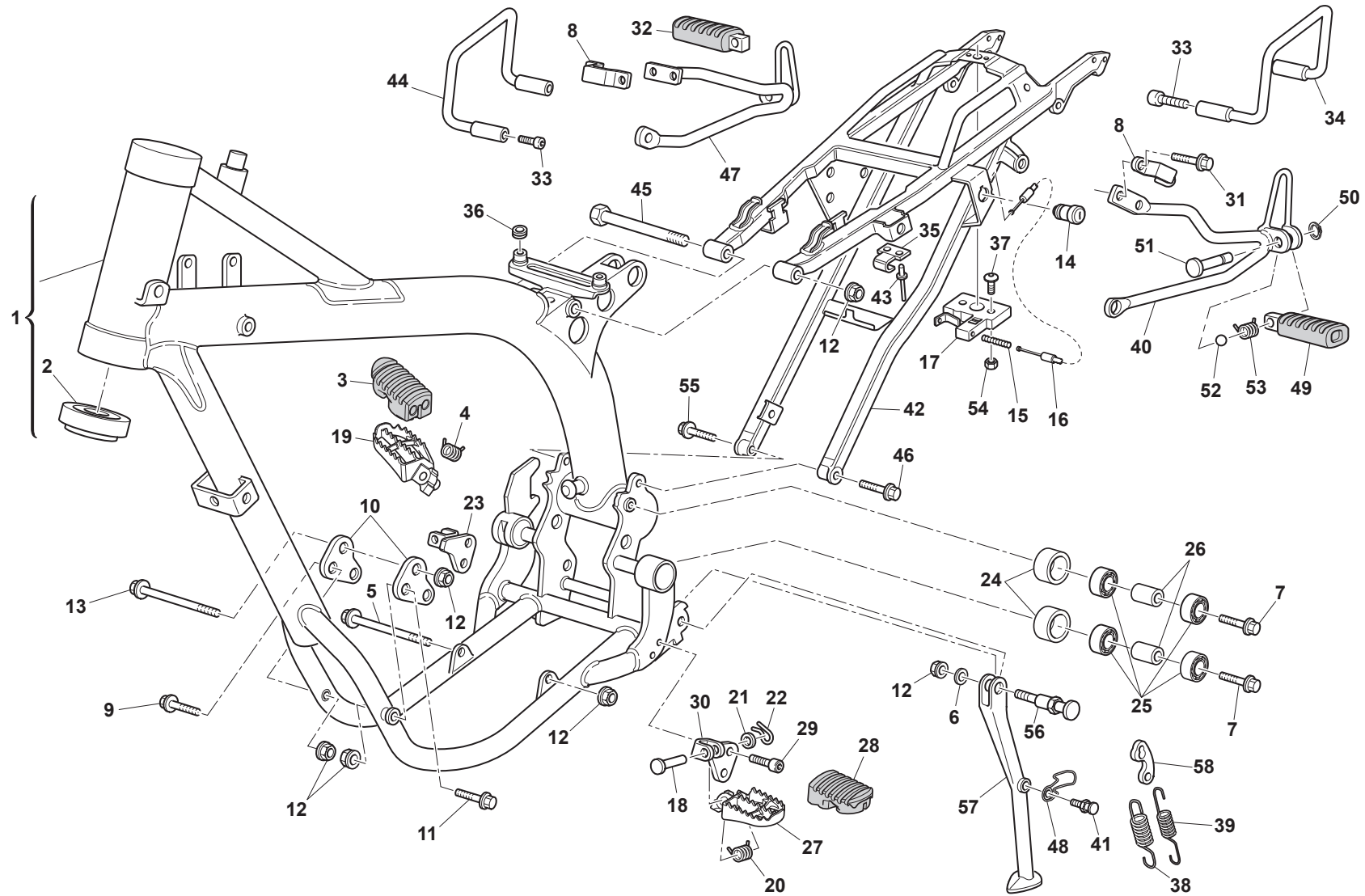



RS-SM 650R/2016

TELAIO, PEDANE - FRAME, FOOT RESTS CADRE, REPOSE PIEDS - RAHMEN, FUSSBRETT BASTIDOR, REPOSAPIES

TAVOLA
DRAWING
TABLE
BILD
TABLA

16

Note Notes Notes Marke Notas	Pos. No. N. Index Pos.	N. Cod. Code No. Nr. Code Code Nr N. Cod.	Q.tà Q.ty Q.te M.ge C.ad	DENOMINAZIONE	NAME	DESIGNATION	BESHREIBUNG	DENOMINACION
	1	8A00H0882	1	TELAIO	FRAME	CADRE	RAHMEN	BASTIDOR
	2	800087243	2	CUSCINETTO A RULLI CONICI 29-48-17,5	CONICAL ROLLERS BEARING 29-48-17.5	ROULEMENT A ROULEAUX CONIQUES 29-48-17,5	KEGELROLLENLAGER 29-48-17,5	COJINETE DE RODILLOS CONICO 29-48-17,5
	3	F000P00139	1	GOMMA PEDANA DESTRA	COVER, FOOTREST RH	CAOUTCHOUC REPOSE-PIEDS DROIT	TRITTBRETTGUMMI RECHT	GOMA ESTRIBO DERECHO
	4	800096908	1	MOLLA PEDANA	SPRING, FOOTREST	RESSORT REPOSE-PIEDS	FEDER, FUSSRASTE	MUELLE ESTRIBO
	5	YP0073458	1	PERNO INFERIORE MOTORE M8X1,25X135	AXLE, ENGINE FIXING M8X1.25X135	PIVOT SUPPORT MOTEUR M8X1,25X135	MOTORBEFESTIGUNGZAPFEN M8X1,25X135	PERNO FIJACION MOTOR M8X1,25X135
	6	62ND15769	1	ROSETTE ELASTICA	WASHER	RONDELLE	SCHEIBE	ARANDELA
	7	ZC0069056	1	VITE TEF M8X1,25X30 CH12	SCREW TEF M8X1.25X30 CH12	VIS TEF M8X1,25X30 CH12	SCHRAUBE TEF M8X1,25X30 CH12	TORNILLO TEF M8X1,25X30 CH12
	8	800071091	2	CAVALLOTTO	U-BOLT	BRIDE	BUEGELBOLZEN	PUENTE
	9	Z00062795	2	VITE TEF M8X1,25X50 CH12	SCREW TEF M8X1.25X50 CH12	VIS TEF M8X1,25X50 CH12	SCHRAUBE TEF M8X1,25X50 CH12	TORNILLO TEF M8X1,25X50 CH12
	10	8000H0919	2	SUPPORTO MOTORE ANTERIORE	BRACKET-ENGINE, FRONT	SUPPORT MOTEUR AVANT	MOTORKONSOLE, VORNE	SOPORTE MOTOR DELANTERO
	11	Z00062795	2	VITE TEF M8X1,25X50 CH12	SCREW TEF M8X1.25X50 CH12	VIS TEF M8X1,25X50 CH12	SCHRAUBE TEF M8X1,25X50 CH12	TORNILLO TEF M8X1,25X50 CH12
	12	Y00043928	6	DADO AUTOBLOCCANTE M8X1,25	NUT, SELF LOCKING M8X1.25	ECROU AUTOBLOQUANT M8X1,25	SELBSTSPERRENDE MUTTER M8X1,25	TUERCA AUTOBLOQUEANTE M8X1,25
	13	Y00073458	2	PERNO ANTERIORE MOTORE M8X1,25X105	AXLE, ENGINE FIXING M8X1.25X105	PIVOT SUPPORT MOTEUR M8X1,25X105	MOTORBEFESTIGUNGZAPFEN M8X1,25X105	PERNO FIJACION MOTOR M8X1,25X105
	14	8000H1798	1	SERRATURA SELLA	LOCK SET, SEAT	SERRURE SELLE	SCHLOSS SATTEL	CERRADURA ASIEN TO
	15	8000H2015	1	MOLLA	SPRING	RESSORT	FEDER	MUELLE
	16	8000H2016	1	CAVO APERTURA SELLA	CABLE, SEAT OPENING	CABLE OUVERTURE SELLE	KABEL SITZBANKOFFNUNG	CABLE ABERTURA ASIEN TO
	17	8000H2127	1	CHIAVISTELLO SELLA	STRIKER, SEAT LOCK	VERROU SERRURE SELLE	RIEGEL VERSCHLUSS SATTEL	CERROJO CERRADURA ASIEN TO
	18	Y00073140	2	PERNO CLEVIS	PIN, CLEVIS	BOULON, A GOUPILLE	LASTOSENSTIFT	PASADOR CON HOYO
	19	80A089953	1	PEDANA ANTERIORE DESTRA	FOOTREST, FRONT RH	REPOSE-PIEDS AVANT DROIT	VORNE FUSSRASTE, RECHTS	ESTRIBO DELANTERO DERECHO
	20	800096907	2	MOLLA PEDANA	SPRING, FOOTREST	RESSORT REPOSE-PIEDS	FEDER, FUSSRASTE	MUELLE ESTRIBO
	21	ZA0001815	2	RONDELLA 16X10X1	WASHER 16X10X1	RONDELLE 16X10X1	SCHEIBE 16X10X1	ARANDELA 16X10X1
	22	64ND20068	2	COPIGLIA 18X1,8	SPLIT PIN 18X1.8	GOUPILLE 18X1,8	SPLINT 18X1,8	CLAVIJA 18X1,8
	23	F000P00206	1	SUPPORTO PEDANA ANTERIORE DESTRA	BRACKET, FRONT FOOTREST RH	SUPPORT REPOSE-PIEDS AVANT DROIT	VORNEFUSSRASTENHALTER RECHTS	SOPORTE ESTRIBO DELANTERO DERECHO
	24	8AA059433	2	RULLO TENDICATENA	ROLLER, CHAIN TENSIONER	ROULEAU, TENDEUR CHAINE	ROLLE, KETTENSANNER	RODILLO, TENSIONADOR CADENA
	25	800063312	2	CUSCINETTO A SFERE 608 2RS	BEARING, BALL 608 2RS	ROULEMENT A BILLES 608 2RS	KUGELLAGER 608 2RS	COJINETE DE BOLAS 608 2RS
	26	8A0059434	2	DISTANZIALE 12X8,2X9	SPACER 12X8.2X9	ENTRETOISE 12X8,2X9	ABSTANDHALTER 12X8,2X9	DISTANCIADOR 12X8,2X9
	27	80A089962	1	PEDANA ANTERIORE SINISTRA	FOOTREST, FRONT LH	REPOSE-PIEDS AVANT GAUCHE	VERDER FUSSRASTE LINKS	ESTRIBO DELANTERO IZQUERDO
	28	F000P00138	1	GOMMA PEDANA SINISTRA	COVER, FOOTREST LH	CAOUTCHOUC REPOSE-PIEDS GAUCHE	TRITTBRETTGUMMI LINKER	GOMA ESTRIBO IZQUIERDA
	29	8000B1959	4	VITE TEF M8X1,25X25 CH12	SCREW TEF M8X1,25X25 CH12	VIS TEF M8X1,25X25 CH12	SCHRAUBE TEF M8X1,25X25 CH12	TORNILLO TEF M8X1,25X25 CH12
	30	80B083987	1	SUPPORTO PEDANA ANTERIORE SINISTRA	BRACKET, FRONT FOOTREST LH	SUPPORT REPOSE-PIEDS AVANT GAUCHE	VORNEFUSSRASTENHALTER LINKS	SOPORTE ESTRIBO DELANTERO IZQUERDO
	31	Z00069056	4	VITE TE M8X1,25X20 CH12	SCREW TE M8X1.25X20 CH12	VIS TE M8X1,25X20 CH12	SCHRAUBE TE M8X1,25X20 CH12	TORNILLO TE M8X1,25X20 CH12
	32	8A0085928	1	PEDANA POSTERIORE DESTRA	FOOTREST, REAR RH	REPOSE-PIEDS ARRIERE DROIT	FUSSRASTE HINTEN, RECHTS	ESTRIBO TRASERO DERECHO
	33	60ND02555	4	VITE	SCREW	VIS	SCHRAUBE	TORNILLO

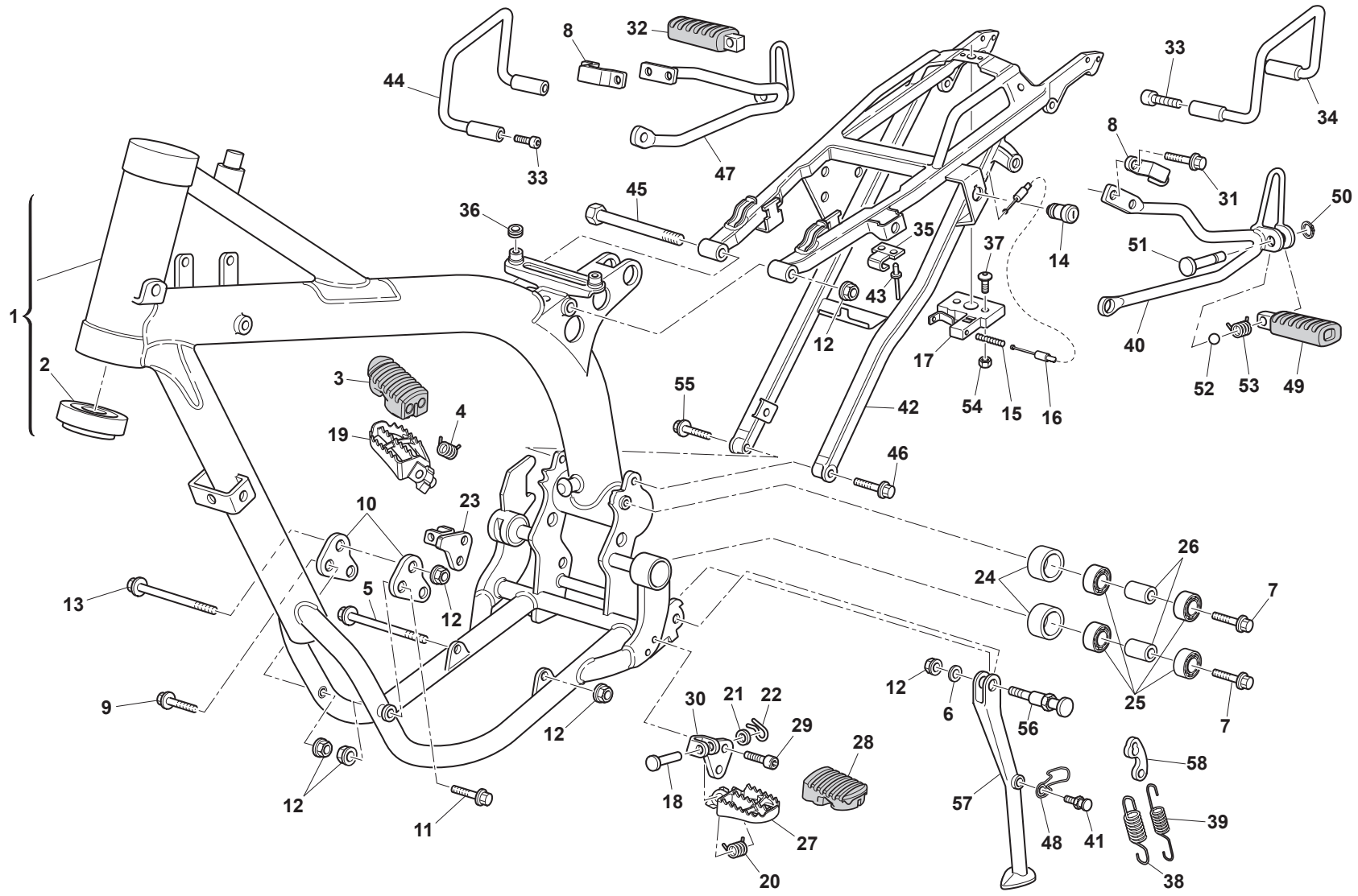



RS-SM 650R/2016

TELAIO, PEDANE - FRAME, FOOT RESTS CADRE, REPOSE PIEDS - RAHMEN, FUSSBRETT BASTIDOR, REPOSAPIES

TAVOLA
DRAWING
TABLE
BILD
TABLA

16

Note Notes Notes Marke Notas	Pos. No. N. Index Pos.	N. Cod. Code No. Nr. Code Code Nr N. Cod.	Q.tà Q.ty Q.te M.ge C.ad	DENOMINAZIONE	NAME	DESIGNATION	BESHREIBUNG	DENOMINACION
	34	8000H1853	1	MANIGLIA PASSEGGERO SINISTRA	HANDLE, PILLION RIDER LH	POIGNEE PASSAGER GAUCHE	LINKER BEIFAHREER HANDGRIFF	MANILLA PASAJERO IZQUIERDA
	35	8000A6062	1	PIASTRINA	PLATE	PLAQUETTE	PLAETTCHEN	PLETINA
	36	8000H2374	3	SILENTBLOCK	DAMPER	SILENTBLOC	SCHWINGUNGSDAEMPFER	CASQUILLO ELASTICO
	37	Z00055697	2	VITE TCEI M6X25	SCREW TCEI M6X25	VIS TCEI M6X25	SCHRAUBE TCEI M6X25	TORNILLO TCEI M6X25
	38	8000A0269	1	MOLLA CAVALLETTO LATERALE ESTERNA	SPRING SIDE STAND OUTER	RESSORT EXTERIEUR BEQUILLE LATERAL	AUSSEREFEDER, SEITENSTAENDER	MUELLE EXTERIOR CABALLETE LATERAL
	39	8000A0268	1	MOLLA CAVALLETTO LATERALE INTERNA	SPRING, SIDE STAND INNER	RESSORT INTERIEUR BEQUILLE LATERAL	INNEREFEDER, KIPPSTAENDERFEDER	MUELLE INTERIOR CABALLETE LATERAL
	40	8A00A5261	1	SUPPORTO PEDANA POSTERIORE SINISTRA	BRACKET, PILLION FOOTREST LH	SUPPORT REPOSE-PIEDS ARRIERE GAUCHE	HINTERFUSSRASTENHALTER LINKS	SOPORTE ESTRIBO TRASERO IZQUERDO
	41	8000H0235	1	PERNO PORTAMOLLE CAVALLETTO	PIN SPRING	GOUJON RESSORT	BOLZEN, FEDER	PERNO MUELLE
	42	8A00H1005	1	TELAIO POSTERIORE	REAR FRAME	CADRE ARRIERE	HINTERER RAHMEN	BASTIDOR TRASERO
	43	800033373	2	RIVETTO A STRAPPO 3,3X14	SHEAR RIVET 3.3X14	RIVET ARRACHAGE 3,3X14	REISSNIETE 3,3X14	REMACHE A DESGARRE 3,3X14
	44	8000H1852	1	MANIGLIA DESTRA	HANDLE RH	POIGNEE DROITE	RECHTER HANDGRIFF	MANILLA DERECHA
	45	YA0069111	1	VITE M8X1,25X140 MM	SCREW M8X1.25X140 MM	VIS M8X1,25X140 MM	SCHRAUBE M8X1,25X140 MM	TORNILLO M8X1,25X140 MM
	46	60ND02562	1	VITE TCEI M8X1,25X55 MM	SCREW TCEI M8X1.25X55 MM	VIS TCEI M8X1,25X55 MM	SCHRAUBE TCEI M8X1,25X55 MM	TORNILLO TCEI M8X1,25X55 MM
	47	8A00A5262	1	SUPPORTO PEDANA POSTERIORE SINISTRA	BRACKET, PILLION FOOTREST LH	SUPPORT REPOSE-PIEDS ARRIERE GAUCHE	HINTERFUSSRASTENHALTER LINKS	SOPORTE ESTRIBO TRASERO IZQUERDO
	48	8000H2989	1	LEVA CAVALLETTO LATERALE	SIDE STAND LEVER	LEVIER BEQUILLE LATERALE	SEITENSTAENDERHEBEL	PALANACA CABALLETE LATERAL
	49	8A0085929	1	PEDANA POSTERIORE SINISTRA	FOOTREST, REAR LH	REPOSE PIEDS ARRIERE GAUCHE	FUSSRASTE HINTEN , LINKS	ESTRIBO TRASERO IZQUERDO
	50	66ND21308	2	ANELLO SEEGER 11X5X0,7	CIRCLIP 11X5X0,7	CIRCLIP 11X5X0,7	SEEGERRING 11X5X0,7	ANILLO SEEGER 11X5X0,7
	51	ZB0053546	2	PERNO PEDANA	PIN, FOOTREST	PIVOT REPOSE-PIEDS	BOLZEN, FUSSREST	PERNO ESTRIBO
	52	6BN021507	2	SFERA 1/4	BALL 1/4	BILLE 1/4	KUGEL 1/4	BOLA 1/4
	53	800062655	2	MOLLA	SPRING	RESSORT	FEDER	MUELLE
	54	Z00044240	2	DADO AUTOBLOCCANTE M6X1 CH10	NUT, SELF LOCKING M6X1 CH10	ECROU AUTOBLOQUANT M6X1 CH10	SELBSTSPERRENDE MUTTER M6X1 CH10	TUERCA AUTOBLOQUEANTE M6X1 CH10
	55	ZB0062733	1	VITE TEF M8X1,25X45 CH12	SCREW TEF M8X1.25X45 CH12	VIS TEF M8X1,25X45 CH12	SCHRAUBE TEF M8X1,25X45 CH12	TORNILLO TEF M8X1,25X45 CH12
	56	800097976	1	VITE M8X1,25X25	SCREW M8X1.25X25	VIS M8X1,25X25	SCHRAUBE M8X1,25X25	TORNILLO M8X1,25X25
	57	8000H0234	1	CAVALLETTO LATERALE	STAND, SIDE	BEQUILLE LATERALE	KIPPSTAENDER	CABALLETE LATERAL
	58	8000A0267	1	PIASTRINA PORTAMOLLE CAVALLETTO	LINK, SIDE STAND	PLAQUETTE RESSORT BEQUILLE LATERAL	PLAETTCHEN STAENDERFEDER	PLACA MUELLE CABALLETE

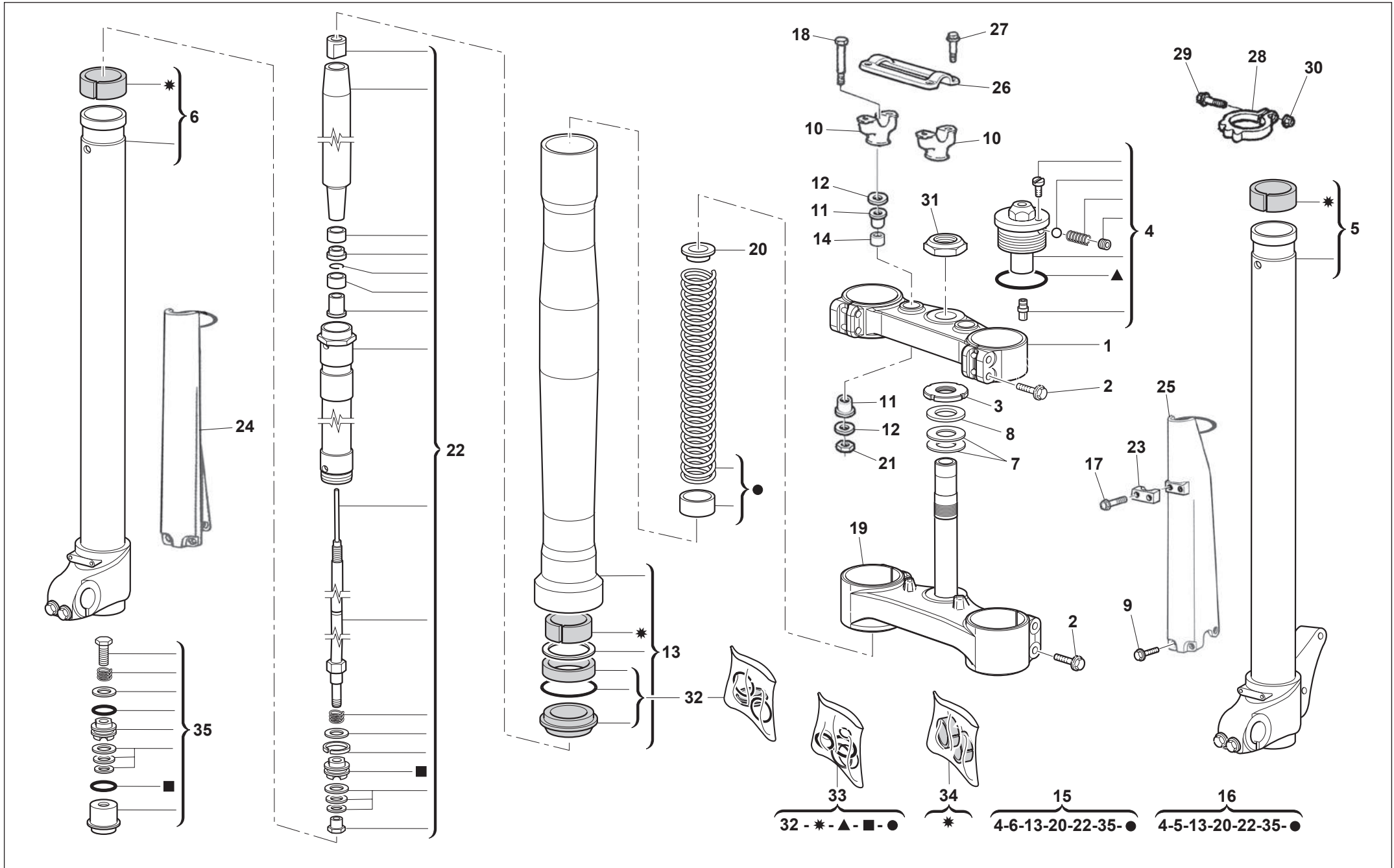

**RS-SM 650R/2016**
SOSPENSIONE ANTERIORE - FRONT FORK ASSEMBLY
SUSPENSION AVANT - VORDERTELESKOPGABEL
SUSPENSION DELANTERA
TAVOLA
DRAWING
TABLE
BILD
TABLA**17**

Note Notes Notes Marke Notas	Pos. No. N. Index Pos.	N. Cod. Code No. Nr. Code Code Nr N. Cod.	Q.tà Q.ty Q.te M.ge C.ad	DENOMINAZIONE	NAME	DESIGNATION	BESHREIBUNG	DENOMINACION
	1	8000H1018	1	PIASTRA FORCELLA SUPERIORE	HEAD, STEERING STEM	TETE DIRECTION	GABELKOPF	TIJA SUPERIOR
	2	Z00062796	8	VITE TEF M6X1,25X40	SCREW TEF M6X1,25X40	VIS TEF M6X1,25X40	SCHRAUBE TEF M6X1,25X40	TORNILLO TEF M6X1,25X40
	3	8A0087717	1	GHIERA CANNOTTO STERZO	BOLT STEERING HEAD TOP	ECROU SUPERIEUR TETE DIRECTION	OBER-GEWINDE, STEUERKOPF	TUERCA SUPERIOR CABEZAL DIRECCION
SM 650R	4	8000A7659	2	TAPPO FODERO FORCELLA	CAP, FRONT FORK	BOUCHON FOURREAU FOURCHE	VERSCHLUSS, HUELSE	TAPON FUNDA HORQUILLA
RS 650R	4	8000H3635	2	TAPPO FODERO FORCELLA	CAP, FRONT FORK	BOUCHON FOURREAU FOURCHE	VERSCHLUSS, HUELSE	TAPON FUNDA HORQUILLA
SM 650R	5	8000H1170	1	STELO FORCELLA SINISTRO	FORK INNER TUBE LH	TIGE FOURCHE GAUCHE	GABELSTANGE, LINKS	MANGUERA HORQUILLA IZQUERDO
RS 650R	5	80A0A7573	1	STELO FORCELLA SINISTRO	FORK INNER TUBE LH	TIGE FOURCHE GAUCHE	GABELSTANGE, LINKS	CANA HORQUILLA IZQUERDO
SM 650R	6	8000H1168	1	STELO FORCELLA DESTRO	FORK INNER TUBE RH	TIGE FOURCHE DROITE	GABELSTANGE, RECHTS	MANGUERA HORQUILLA DERECHO
RS 650R	6	80A098786	1	STELO FORCELLA DESTRO	FORK INNER TUBE RH	TIGE FOURCHE DROITE	GABELSTANGE, RECHTS	CANA HORQUILLA DERECHO
	7	800087745	2	GUARNIZIONE	GASKET	JOINT	DICHTUNG	JUNTA
	8	800087736	1	RONDELLA 40,5X29,5X2 MM	WASHER 40,5X29,5X2 MM	RONDELLE 40,5X29,5X2 MM	SCHEIBE 40,5X29,5X2 MM	ARANDELA 40,5X29,5X2 MM
SM 650R	9	8000A8423	6	VITE FLANGIATA M6X8	BOLT, FLANGE M6X8	VIS A EMBASE M6X8	GEFLANSCHSCHRAUBE M6X8	TORNILLO CON VALONA M6X8
RS 650R	9	8000A8421	6	VITE FLANGIATA	BOLT, FLANGE	VIS A EMBASE	GEFLANSCHSCHRAUBE	TORNILLO CON VALONA
	10	8000H2355	2	CAVALLOTTO MANUBRIO INFERIORE	HOLDER, HANDLE LOWER	BRIDE INFERIEUR GUIDON	KONSOLE, LENKER UNTEN	SOPORTE, INFERIOR MANILLAR
	11	800060233	4	SILENTBLOCK	DAMPER	SILENTBLOC	SCHWINGUNGSDAEMPFER	CASQUILLO ELASTICO
	12	800060234	4	RONDELLA 28X22X10,5X2,5 MM	WASHER 28X22X10,5X2,5 MM	RONDELLE 28X22X10,5X2,5 MM	SCHEIBE 28X22X10,5X2,5 MM	ARANDELA 28X22X10,5X2,5 MM
	13	8A0091474	2	FODERO FORCELLA	FORK OUTER TUBE	FOURREAU FOURCHE	GABEL HUELSE	FUNDA HORQUILLA
	14	8000H3016	2	DISTANZIALE 12X10,1X34	SPACER 12X10,1X34	ENTRETOISE 12X10,1X34	ABSTANDHALTER 12X10,1X34	DISTANCIADOR 12X10,1X34
SM 650R	15	8000H1914	1	GAMBA FORCELLA DESTRA	FRONT CUSHION ASSY RH	JAMBE FOURCHE DROIT	GABELBEIN, RECHTS	PIERNA HORQUILLA DERECHA
RS 650R	15	8000H3633	1	GAMBA FORCELLA DESTRA	FRONT CUSHION ASSY RH	JAMBE FOURCHE DROIT	GABELBEIN, RECHTS	PIERNA HORQUILLA DERECHA
SM 650R	16	8000H1169	1	GAMBA FORCELLA SINISTRA	FRONT CUSHION ASSY LH	JAMBE FOURCHE GAUCHE	GABELBEIN, LINKS	PIERNA HORQUILLA IZQUERDA
RS 650R	16	8000H3639	1	GAMBA FORCELLA SINISTRA	FRONT CUSHION ASSY LH	JAMBE FOURCHE GAUCHE	GABELBEIN, LINKS	PIERNA HORQUILLA IZQUERDA
SM 650R	17	ZA0084658	2	VITE AUTOFILETTANTE	SCREW, TAPPING	VIS TARAUD	GEWINDESCHRAUBE	TORNILLO AUTOROSCANTE
RS 650R	17	Z00084658	2	VITE TEF M5X0,8X16 CH8	SCREW TEF M5X0,8X16 CH8	VIS TEF M5X0,8X16 CH8	SCHRAUBE TEF M5X0,8X16 CH8	TORNILLO TEF M5X0,8X16 CH8
	18	60ND01219	2	VITE TE M10X1,5X65	SCREW TE M10X1,5X65	VIS TE M10X1,5X65	SCHRAUBE TE M10X1,5X65	TORNILLO TE M10X1,5X65
	19	8000B0850	1	PIASTRA FORCELLA INFERIORE	STEM, STEERING	SOCLE DIRECTION	GABELBRUECKE, UNTEN	BASE DIRECCION
	20	800077373	2	SCODELLINO	CUP	COUPELLE	EINSTELLE	COPELA
	21	Z00061314	2	DADO AUTOBLOCCANTE M10X1,5	NUT, SELF LOCKING M10X1,5	ECROU AUTOBLOQUANT M10X1,5	SELBSTSPERRENDE MUTTER M10X1,5	TUERCA AUTOBLOQUEANTE M10X1,5
SM 650R	22	8000B1661	2	POMPANTE FORCELLA	CYLINDER COMP FRONT FORK	CARTUOCHE AMORTISSEMENT	DAEMPFGUNGSELEMENT	CARTUCHO AMORTIGUACION
RS 650R	22	8000H3638	2	POMPANTE FORCELLA	CYLINDER COMP FRONT FORK	CARTUOCHE AMORTISSEMENT	DAEMPFGUNGSELEMENT	CARTUCHO AMORTIGUACION
	23	80D0A0633	1	FERMACAVO	CLAMP, WIRE	COLLIER, CORDON	KABELKLEMME	GRAMPA CORDON
RS 650R	24	80H069338	1	PROTEZIONE STELO FORCELLA DESTRO	GUARD FORK TUBE, RH	PROTECTION TIGE FOURCHE DROITE	GABELSTANGENSCHUTZ RECHTS	PROTECCION VARILLA DERECHA
SM 650R	24	80D0A8482	1	PROTEZIONE STELO FORCELLA DESTRO	GUARD FORK TUBE, RH	PROTECTION TIGE FOURCHE DROITE	GABELSTANGENSCHUTZ RECHTS	PROTECCION VARILLA DERECHA

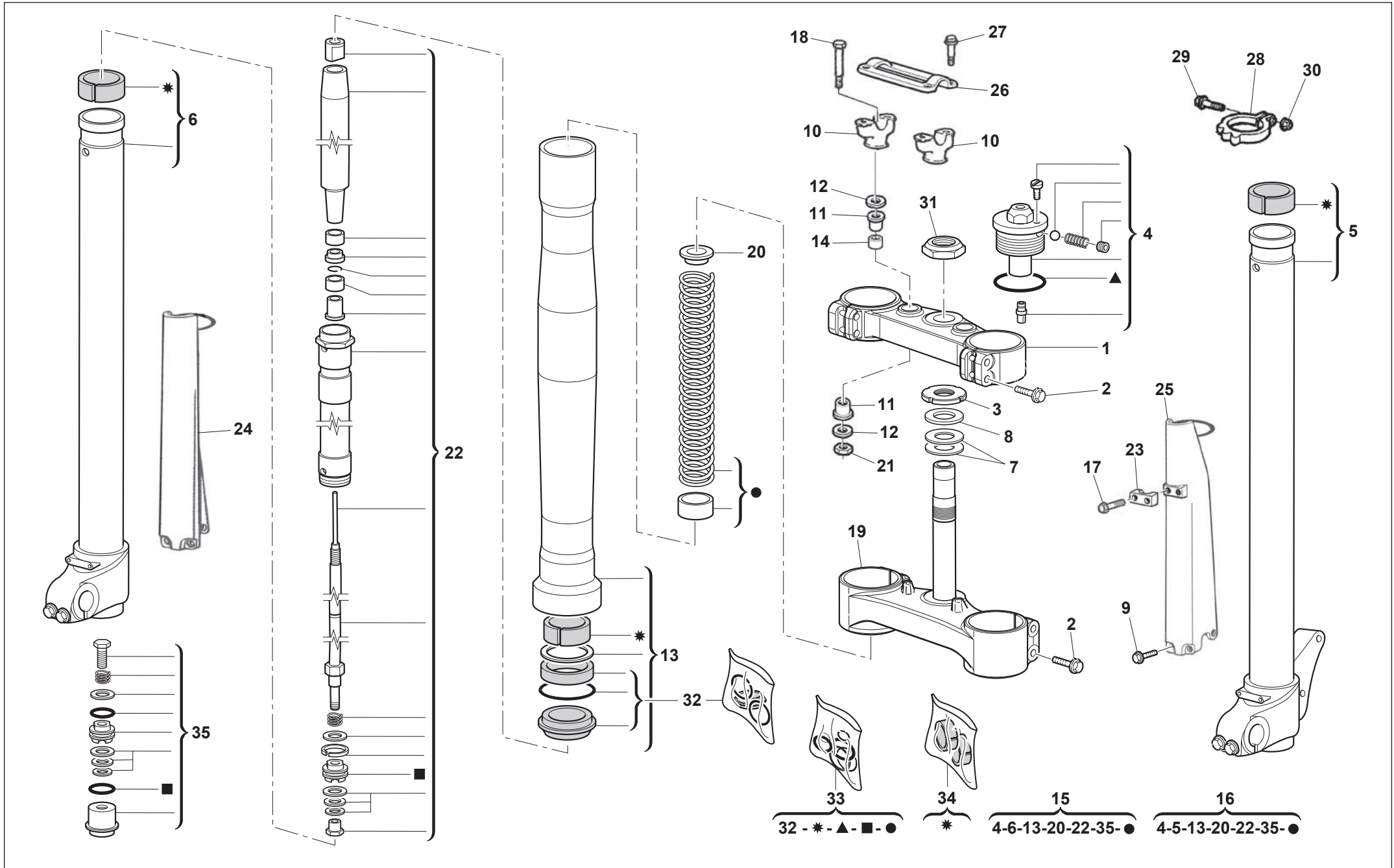

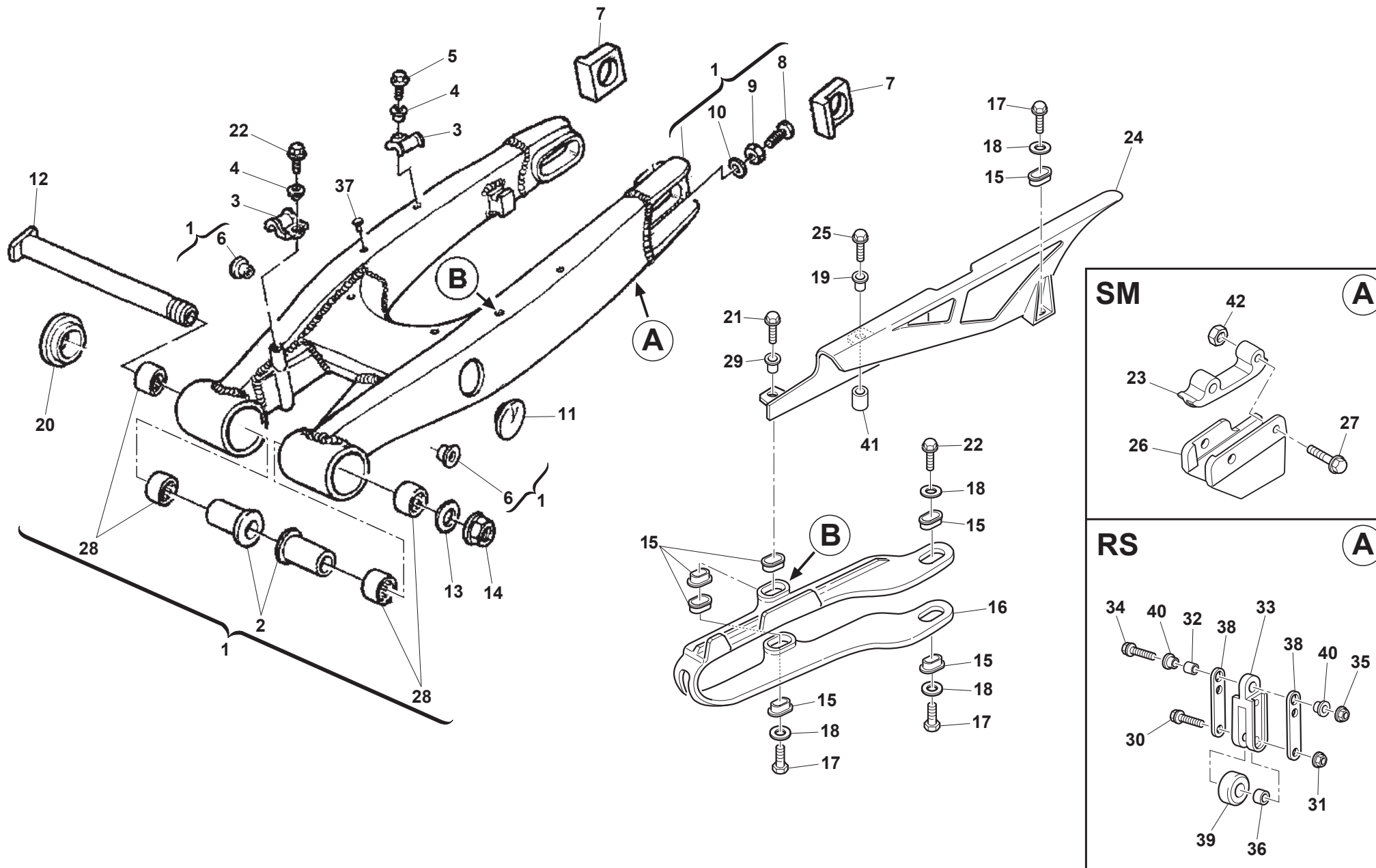

**RS-SM 650R/2016****FORCELLONE POSTERIORE- REAR SWING ARM-
FOURCHE ARRIERE - HINTERGABEL
HORQUILLA TRASERA**TAVOLA
DRAWING
TABLE
BILD
TABLA**18**

Note Notes Notes Marke Notas	Pos. No. N. Index Pos.	N. Cod. Code No. Nr. Code Code Nr N. Cod.	Q.tà Q.ty Q.te M.ge C.ad	DENOMINAZIONE	NAME	DESIGNATION	BESHREIBUNG	DENOMINACION
	1	8000H3743	1	FORCELLONE	REAR SWING ARM ASSY	BRAS OSCILLANT	HINTERE SCHWINGE	BASCULANTE
	2	800083904	2	BOCCOLA 27,5X17X45	BUSH 27.5X17X45	DOUILLE 27,5X17X45	BUCHSE 27,5X17X45	BUJE 27,5X17X45
	3	8000B1166	2	GUIDACAVO	GUIDE, CABLE	PASSE-CABLE	FUHRUNG, KABEL	GUIA CABLE
	4	800069282	2	BOCCOLA 14X7X5,25 MM	BUSH 14X7X5.25 MM	DOUILLE 14X7X5,25 MM	BUCHSE 14X7X5,25 MM	CASQUILLO 14X7X5,25 MM
	5	Z00020536	2	VITE TE AUTOFILETTANTE 4,8X13	SCREW SELF-TAPPING 4.8X13	VIS TARAUD 4,8X13	GEWINDESCHRAUBE 4,8X13	TORNILLO AUTOROSCANTE 4,8X13
	6	8A0087810	2	BUSSOLA LATO CORONA 13MM	BUSH, LEFT 13MM	DOUILLE GAUCHE 13MM	BUCHSE, LINKS 13MM	BUJE, IZQUERDO 13MM
	7	800096941	1	TENDICATENA SINISTRO	ADJUSTER, CHAIN LH	TENDEUR CHAINE GAUCHE	KETTENSPELLER LINKS	TENSIONADOR CADENA IZQUERDO
	7	800096944	1	TENDICATENA DESTRO	ADJUSTER, CHAIN RH	TENDEUR CHAINE DROIT	KETTENSPELLER RECHTS	TENSIONADOR CADENA DERECHO
	8	ZC0061121	2	VITE TE M8X1,25	SCREW TE M8X1.25	VIS TE M8X1,25	SCHRAUBE TE M8X1,25	TORNILLO TE M8X1,25
	9	Z00017810	2	DADO M8X1,25	NUT M8X1.25	ECROU M8X1,25	MUTTER M8X1,25	TUERCA M8X1,25
	10	Z00008536	2	RONDELLA 13X8,4X2	WASHER 13X8.4X2	RONDELLE 13X8,4X2	SCHEIBE 13X8,4X2	ARANDELA 13X8,4X2
	11	80B074388	2	TAPPO	PLUG	BOUCHON	VERSCHLUSS	TAPON
	12	F000P00173	1	PERNO FORCELLONE	AXE REAR SWING ARM	AXE BRAS OSCILLANT	SCHWINGENACHSE	PERNO BASCULANTE
	13	800032388	1	RONDELLA 26X17,2X1,5	WASHER 26X17.2X1.5	RONDELLE 26X17,2X1,5	SCHEIBE 26X17,2X1,5	ARANDELA 26X17,2X1,5
	14	Z00071623	1	DADO FLANGIATO M16X1,5	NUT FLANGE M16X1.5	ECROU BRIDE M16X1,5	GEFLANSCHTE MUTTER M16X1,5	TUERCA CON REBORDE M16X1,5
	15	8000H3033	7	SCODELLINO	CUP	COUPELLE	EINSTELLE	COPELA
	16	8000H1320	1	PATTINO SCORRICATENA FORCELLONE	BUFFER, CHAIN TOUCH DEFENSE	PATIN PROTECTEUR BRAS OSCILLANT	KETTENGLEITFUEHRUNG	PATIN DESLIZAMIENTO CADENA
	17	Z00020536	3	VITE TE AUTOFILETTANTE 4,8X13	SCREW SELF-TAPPING 4.8X13	VIS TARAUD 4,8X13	GEWINDESCHRAUBE 4,8X13	TORNILLO AUTOROSCANTE 4,8X13
	18	Z00036137	4	RONDELLA 11X5,5X1,5	WASHER 11X5.5X1.5	RONDELLE 11X5,5X1,5	SCHEIBE 11X5,5X1,5	ARANDELA 11X5,5X1,5
	19	800097025	3	BOCCOLA	BUSH	DOUILLE	BUCHSE	BUJE
	20	800087027	1	TAPPO PERNO FORCELLONE	CAP, PIVOT COVER	BOUCHON BRAS OSCILLANT	STOPFEN SCHWINGE	TAPON BASCULANTE
	21	ZA0067997	1	VITE TEF M5X0,8X16	SCREW TEF M5X0.8X16	VIS TEF M5X0,8X16	SCHRAUBE TEF M5X0,8X16	TORNILLO TEF M5X0,8X16
	22	Z00067997	2	VITE TEF M5X0,8X12	SCREW TEF M5X0.8 CH8	VIS TEF M5X0,8 CH8	SCHRAUBE TEF M5X0,8 CH8	TORNILLO TEF M5X0,8 CH8
SM 650R	23	F000P00594	1	CRUNA CATENA INTERNO	GUIDE, CHAIN INTERNAL	GUIDE CHAINE INTERNE	KETTENFUEHRUNG INTERN	GUIA CADENA INTERNA
	24	8A00A5311	1	CARTER CATENA	GUARD, CHAIN	CARTER CHAINE	KETTENGEGAEUSE	CARTER CADENA
	25	60ND01059	1	VITE TE M5X0,80X35	SCREW TE M5X0.80X35	VIS TE M5X0,80X35	SCHRAUBE TE M5X0,80X35	TORNILLO TE M5X0,80X35
SM 650R	26	F000P00595	1	CRUNA CATENA ESTERNO	GUIDE, CHAIN EXTERNAL	GUIDE CHAINE EXTÉRIEUR	KETTENFUEHRUNG AUSSEN	GUIA CADENA EXTERIOR
SM 650R	27	Z00062729	2	VITE TEF M6X1X25 CH8	SCREW TEF M6X1X25 CH8	VIS TEF M6X1X25 CH8	SCHRAUBE TEF M6X1X25 CH8	TORNILLO TEF M6X1X25 CH8
	28	800076283	4	GABBIA A RULLI 22X28X11	BEARING, NEEDLE 22X28X11	ROULEMENT A AIGUILLES 22X28X11	NADELLAGER 22X28X11	COJINETE DE AGUJAS 22X28X11
	29	8A0069282	2	DISTANZIALE 14X7X5,25 MM	SPACER 14X7X5.25 MM	ENTRETOISE 14X7X5,25 MM	ABSTANDHALTER 14X7X5,25 MM	DISTANCIADOR 14X7X5,25 MM
RS 650R	30	ZE0067545	2	VITE TEF M6X1X40 CH8	SCREW TEF M6X1X40 CH8	VIS TEF M6X1X40 CH8	SCHRAUBE TEF M6X1X40 CH8	TORNILLO TEF M6X1X40 CH8
RS 650R	31	Z00061313	1	DADO M6X1 H6 CH10	NUT M6X1 H6 CH10	ECROU M6X1 H6 CH10	MUTTER M6X1 H6 CH10	TUERCA M6X1 H6 CH10
RS 650R	32	8A0036984	1	DISTANZIALE 18X8,5	SPACER 18X8.5	ENTRETOISE 18X8,5	ABSTANDHALTER 18X8,5	DISTANCIADOR 18X8,5

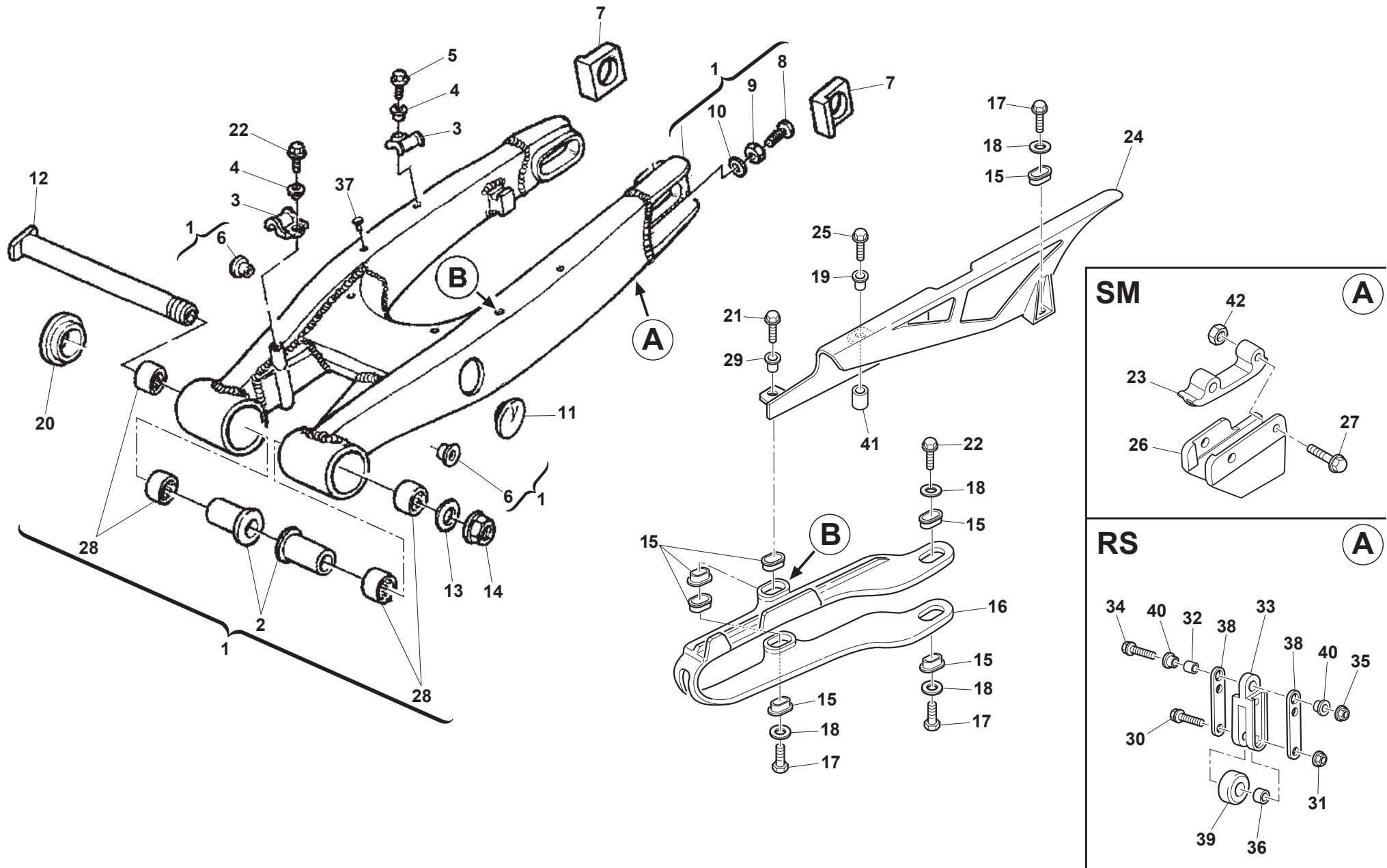

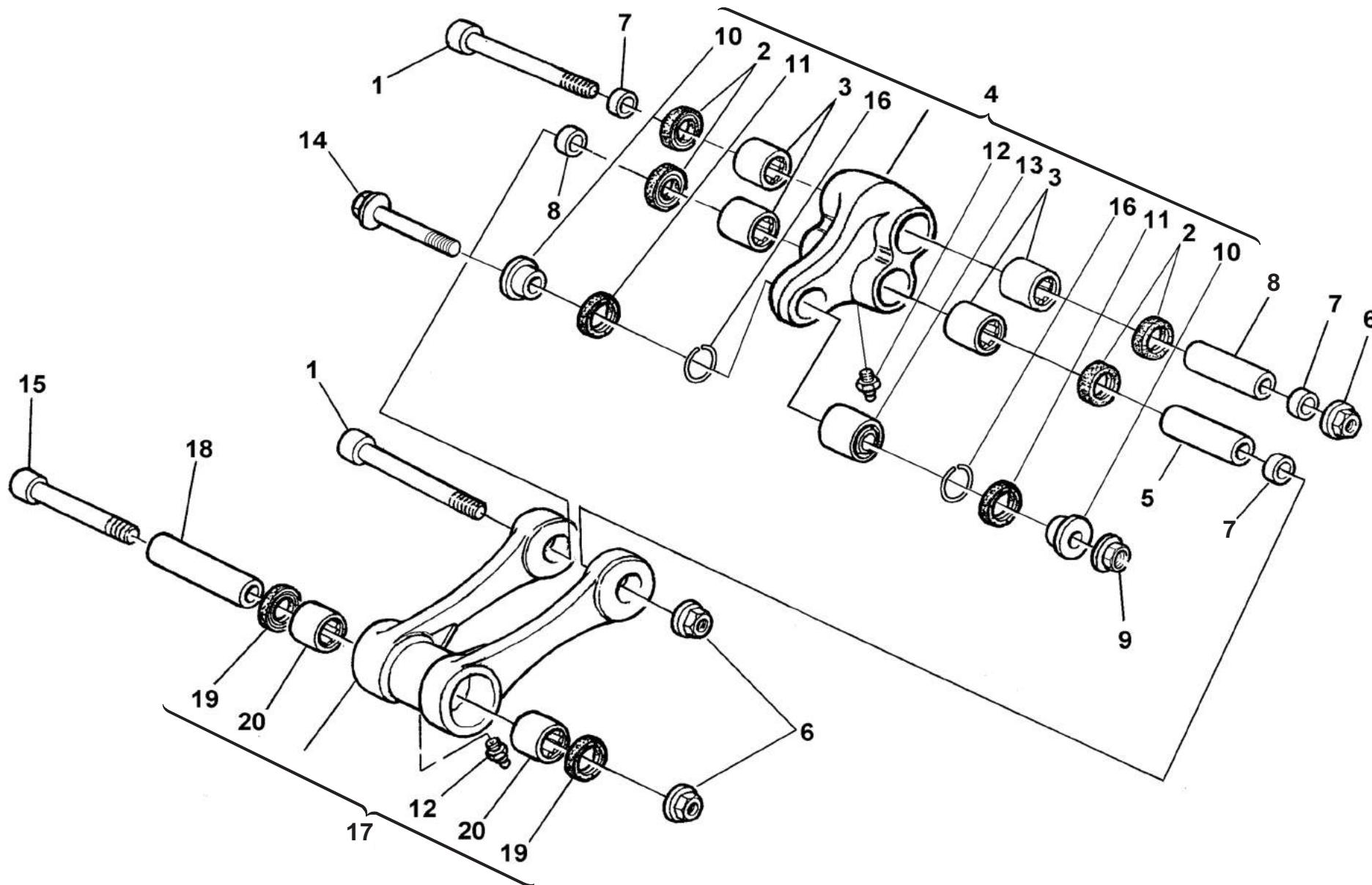

**RS-SM 650R/2016**

LEVERAGGI SOSPENSIONE POSTERIORE - REAR SUSPENSION LINKAGE
LEVIER SUSPENSION ARRIERE - HEBELWERK HINTERHAUFHANGUNG
PALANCA SUSPENSION TRASERA

TAVOLA
DRAWING
TABLE
BILD
TABLA

19

Note Notes Marke Notas	Pos. No. Index Pos.	N. Cod. Code No. Nr. Code Code Nr N. Cod.	Q.tà Q.ty Q.te M.ge C.ad	DENOMINAZIONE	NAME	DESIGNATION	BESHREIBUNG	DENOMINACION
	1	800093124	2	PERNO M12X1,25X103 MM	AXLE M12X1.25X103 MM	AXE M12X1,25X103 MM	ACHSE M12X1,25X103 MM	EJE M12X1,25X103 MM
	2	800086137	4	PARAOLIO 34X26X4	SEAL, OIL 34X26X4	BAGUE D'ETANCHEITE 34X26X4	WELLENDICHTRING 34X26X4	RETEN ACEITE 34X26X4
	3	800086136	4	ASTUCCIO A RULLI HK2216	BEARING, NEEDLE HK2216	ROULEMENT A AIGUILLES HK2216	NADELLAGER HK2216	COJINETE DE AGUJAS HK2216
	4	800097052	1	BILANCIERE SOSPENSIONE POSTERIORE	SWINGARM, CUSHION RELAY	CULBUTEUR SUSPENSION ARRIERE	KIPPSCHWINGE, HINTEN FEDERUNG	BRAZO SUSPENSION TRASERO
	5	800086176	1	SPINOTTO 22X15X50,4	WRIST PIN 22X15X50.4	GOUJON 22X15X50,4	BOLZEN 22X15X50,4	PASADOR 22X15X50,4
	6	Z00042023	3	DADO FLANGIATO M12X1,25	NUT FLANGE M12X1.25	ECROU BRIDE M12X1,25	GEFLANSCHTE MUTTER M12X1,25	TUERCA CON REBORDE M12X1,25
	7	8000H3015	2	BUSSOLA 26X15X5	BUSH 26X15X5	DOUILLE 26X15X5	BUCHSE 26X15X5	CASQUILLO 26X15X5
	8	8D0086176	1	SPINOTTO	PIN	GOUJON	BOLZEN	EJE
	9	Z00042022	1	DADO M10X1,25	NUT M10X1.25	ECROU M10X1,25	MUTTER M10X1,25	TUERCA M10X1,25
	10	151133302	2	BOCCOLA	BUSH	DOUILLE	BUCHSE	BUJE
	11	800038767	2	PARAOLIO 26X15X4	OIL SEAL 26X15X4	BAGUE D'ETANCHEITE 26X15X4	WELLENDICHTRING 26X15X4	RETEN DE ACEITE 26X15X4
	12	800001412	2	INGRASSATORE M6X1	NIPPLE, GREASE M6X1	GRAISSEUR M6X1	SCHMIERNIPPEL M6X1	NIPLE GRASERA M6X1
	13	800072168	1	SNODO SFERICO 12X26X16	BALL JOINT 12X26X16	JOINT A ROTULE 12X26X16	KUGELGELENK 12X26X16	ROTULA ESFERICA 12X26X16
	14	ZD0062797	1	VITE TE M10X1,25X47 CH14	SCREW TE M10X1.25X47 CH14	VIS TE M10X1,25X47 CH14	SCHRAUBE TE M10X1,25X47 CH14	TORNILLO TE M10X1,25X47 CH14
	15	8B0093124	1	VITE M12X1,25X131	SCREW M12X1.25X131	VIS M12X1,25X131	SCHRAUBE M12X1,25X131	TORNILLO M12X1,25X131
	16	800090561	2	GUARNIZIONE 28X24X2	GASKET 28X24X2	JOINT 28X24X2	DICHTUNG 28X24X2	JUNTA 28X24X2
	17	8000A4428	1	BIELLA SOSPENSIONE POSTERIORE	ARM RELAY, REAR CUSHION LEVER	BIELLE SUSPENSION ARRIERE	PLEUELSTANGE HINTEN FEDERUNG	BIELA SUSPENSION TRASERA
	18	800097050	1	SPINOTTO	PIN	GOUJON	BOLZEN	EJE
	19	800038521	2	PARAOLIO 28X22X4	SEAL, OIL 28X22X4	BAGUE D'ETANCHEITE 28X22X4	WELLENDICHTRING 28X22X4	RETEN DE ACEITE 28X22X4
	20	8000A4427	2	ASTUCCIO A RULLI 28X 22X20	BEARING, NEEDLE 28X 22X20	CAGE A AIGUILLE 28X 22X20	NADELLAGER 28X 22X20	COJINETE DE AGUJAS 28X 22X20

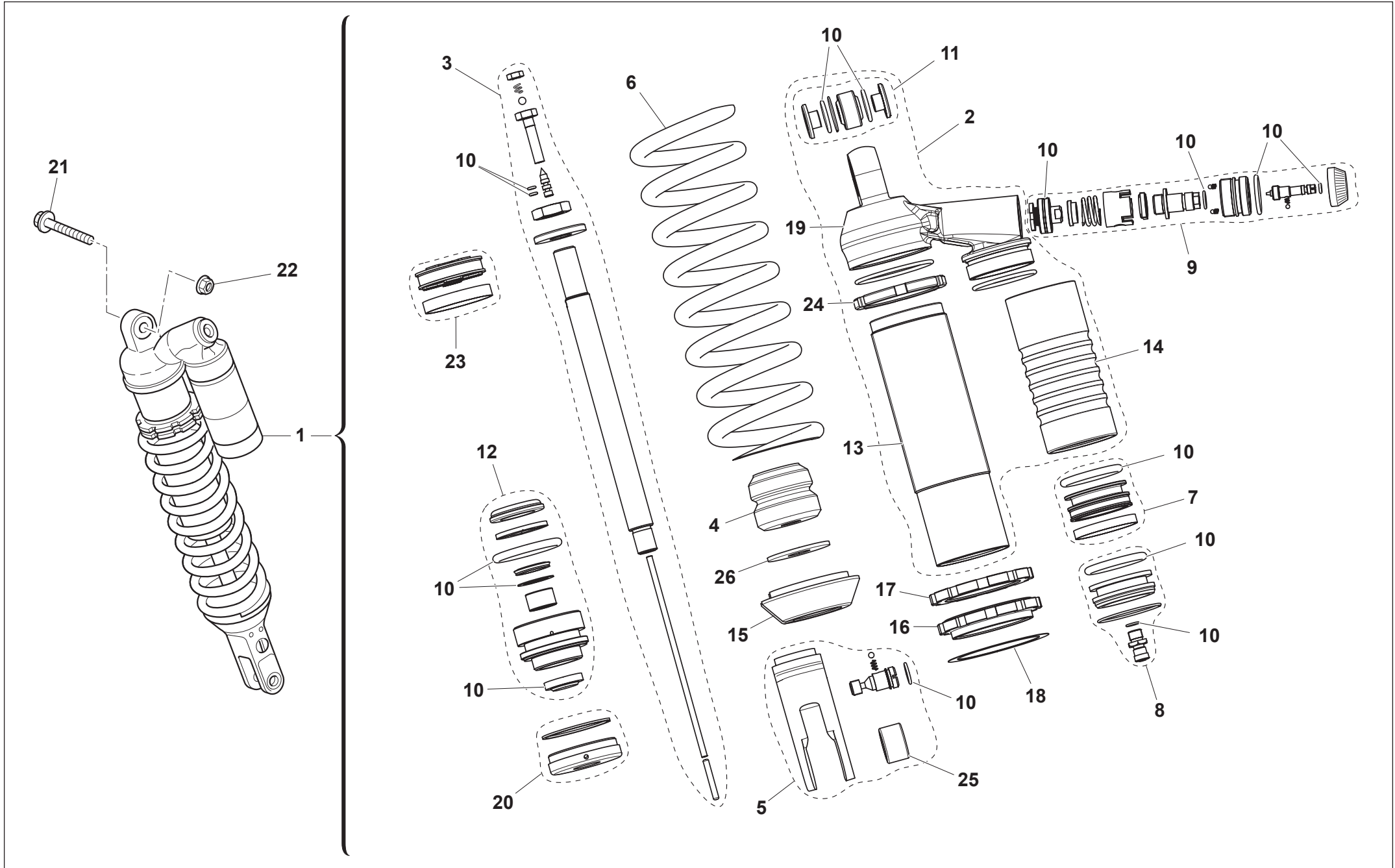



RS-SM 650R/2016

AMMORTIZZATORE POSTERIORE- REAR SUSPENSION SUSPENSION ARRIERE- HINTERHAUFHANGUNG SUSPENSION TRASERA

TAVOLA
DRAWING
TABLE
BILD
TABLA

20

Note Notes Marke Notas	Pos. No. Index Pos.	N. Cod. Code No. Nr. Code Code Nr N. Cod.	Q.tà Q.ty Q.te M.ge C.ad	DENOMINAZIONE	NAME	DESIGNATION	BESHREIBUNG	DENOMINACION
SM 650R	1	8B00A5312	1	AMMORTIZZATORE POSTERIORE	SHOCK ABSORBER, REAR	AMORTISSEUR ARRIERE	HINTERER FEDERBEIN	AMORTIGUADOR TRASERO
RS 650R	1	8B00A6190	1	AMMORTIZZATORE POSTERIORE	SHOCK ABSORBER, REAR	AMORTISSEUR ARRIERE	HINTERER FEDERBEIN	AMORTIGUADOR TRASERO
	2	8000H2761	1	CORPO AMMORTIZZATORE POSTERIORE	DAMPER COMP., REAR	GROUPE CORPS AMORTISSEUR	STOSSDAEMPFERKOERPER	CORPO AMORTIGUADOR
SM 650R	3	8000H2772	1	STELO AMMORTIZZATORE POSTERIORE	ROD, SHOCKABSORBER	TIGE AMORTISSEUR	STANGE, FEDERBEIN	VARILLA AMORTIGUADOR
RS 650R	3	F000P00752	1	STELO AMMORTIZZATORE POSTERIORE	ROD, SHOCKABSORBER	TIGE AMORTISSEUR	STANGE, FEDERBEIN	VARILLA AMORTIGUADOR
	4	8000A6670	1	TAMPONE FINE CORSA	SPINDLE, TAPER	CAOUTCHOUC BUTEE	ANSCHLAGGUMMI	GOMA, TAQUE
	5	800098489	1	GRUPPO FORCELLA	FORK ASSY	GROUPE FOURCHE	GABELGRUPPE	GRUPO HORQUILLA
	6	800098520	1	MOLLA AMMORTIZZATORE K=6,4 KG/MM	SPRING, SHOCK ABSORBER K=6,4 KG/MM	RESSORT, AMORTISSEUR K=6,4 KG/M	FEDER HINTERER FEDERBEIN K=6,4 KG/MM	MUELLE AMORTIGUADOR K=6,4 KG/MM
	7	8000A5071	1	DIAFRAMMA	DIAPHRAGM	DIAPHRAGME	MEMBRAN	MEMBRANA
	8	800098491	1	SERBATOIO AMMORTIZZATORE	TANK, SHOCK ABSORBER	RESERVOIR, AMORTISSEUR	TANK, FEDERBEIN	DEPOSITO AMORTIGUADOR
	9	8000H2762	1	GRUPPO REGOLAZIONE AMMORTIZZATORE	ADJUSTER SET, SHOCK ABSORBER	GROUPE REGLAGE AMORTISSEUR ARRIERE	REGLERGRUPPE, HINTER FEDERBEIN	GRUPO REGULACION AMORTIGUADOR TRASERO
	10	8000A5364	1	GRUPPO REVISIONE AMMORTIZZATORE	OVERHAUL SET, REAR SHOCK ABSORBER	GROUPE REVISION AMORTISSEUR ARRIERE	HINTER FEDERBEIN EBERHOLUNGSSATZ	GRUPO REVISION AMORTIGUADOR TRASERO
	11	800089089	1	BOCCOLA AMMORTIZZATORE	BUSH, DAMPER	BAGUE AMORTISSEUR	BUCHSE, FEDERBEIN	BUJE, AMORTIGUADO
	12	8000H2764	1	GUIDA STELO AMMORTIZZATORE	CASE, ROD GUIDE	BOITE, GUIDE TIGE AMORTISSEUR	GEHAEUSE, STANGEN FUEHERUNG	CAJA, GUIA VARILLA AMORTIGUADOR
	13	8000A6672	1	CORPO AMMORTIZZATORE POSTERIORE	DAMPER COMP., REAR	GROUPE CORPS AMORTISSEUR	STOSSDAEMPFERKOERPER	CORPO AMORTIGUADOR
	14	8000B1920	1	SERBATOIO AMMORTIZZATORE	TANK, SHOCK ABSORBER	RESERVOIR, AMORTISSEUR	TANK, FEDERBEIN	DEPOSITO AMORTIGUADOR
	15	800098496	1	FONDELLO	CUP	GODET	DECKEL	CAZOLETA
	16	800098497	1	GHIERA	RING NUT	ECROU A BAGUE	RINGMUTTER	VIROLA
	17	800098498	1	CONTROGHIERA	RING NUT	ECROU A BAGUE	RINGMUTTER	VIROLA
	18	800098499	1	RONDELLA	WASHER	RONDELLE	SCHEIBE	ARANDELA
	19	8000H2767	1	SUPPORTO SERBATOIO	BRACKET, TANK	SUPPORT RESERVOIR	HALTERUNG, TANK	SOPORTE DEPOSITO
	20	8000H2765	1	GRUPPO TAPPO AMMORTIZZATORE	CAP SET, REAR SHOCK ABSORBER	GROUPE BOUCHON AMORTISSEUR ARRIERE	HINTER FEDERBEIN PFROPFENSATZ	GRUPO TAPON AMORTIGUADOR TRASERO
	21	ZD0062797	1	VITE TE M10X1,25X47 CH14	SCREW TE M10X1,25X47 CH14	VIS TE M10X1,25X47 CH14	SCHRAUBE TE M10X1,25X47 CH14	TORNILLO TE M10X1,25X47 CH14
	22	Z00042022	1	DADO M10X1,25	NUT M10X1,25	ECROU M10X1,25	MUTTER M10X1,25	TUERCA M10X1,25
	23	8000H2766	1	GRUPPO PISTONE + FASCIA	PISTON + BAND ASSY	GROUPE PISTON + BANDE	GRUPPE KOLBEN + BAND	GRUPO PISTON + BANDA
	24	8000B1923	1	GHIERA	RING NUT	ECROU A BAGUE	RINGMUTTER	VIROLA
RS 650R	25	F000P00753	1	DISTANZIALE	SPACER	ENTRETOISE	ABSTANDHALTER	DISTANCIADOR
	26	8000B1924	1	RANELLA	WASHER	RONDELLE	SCHEIBE	ARANDELA

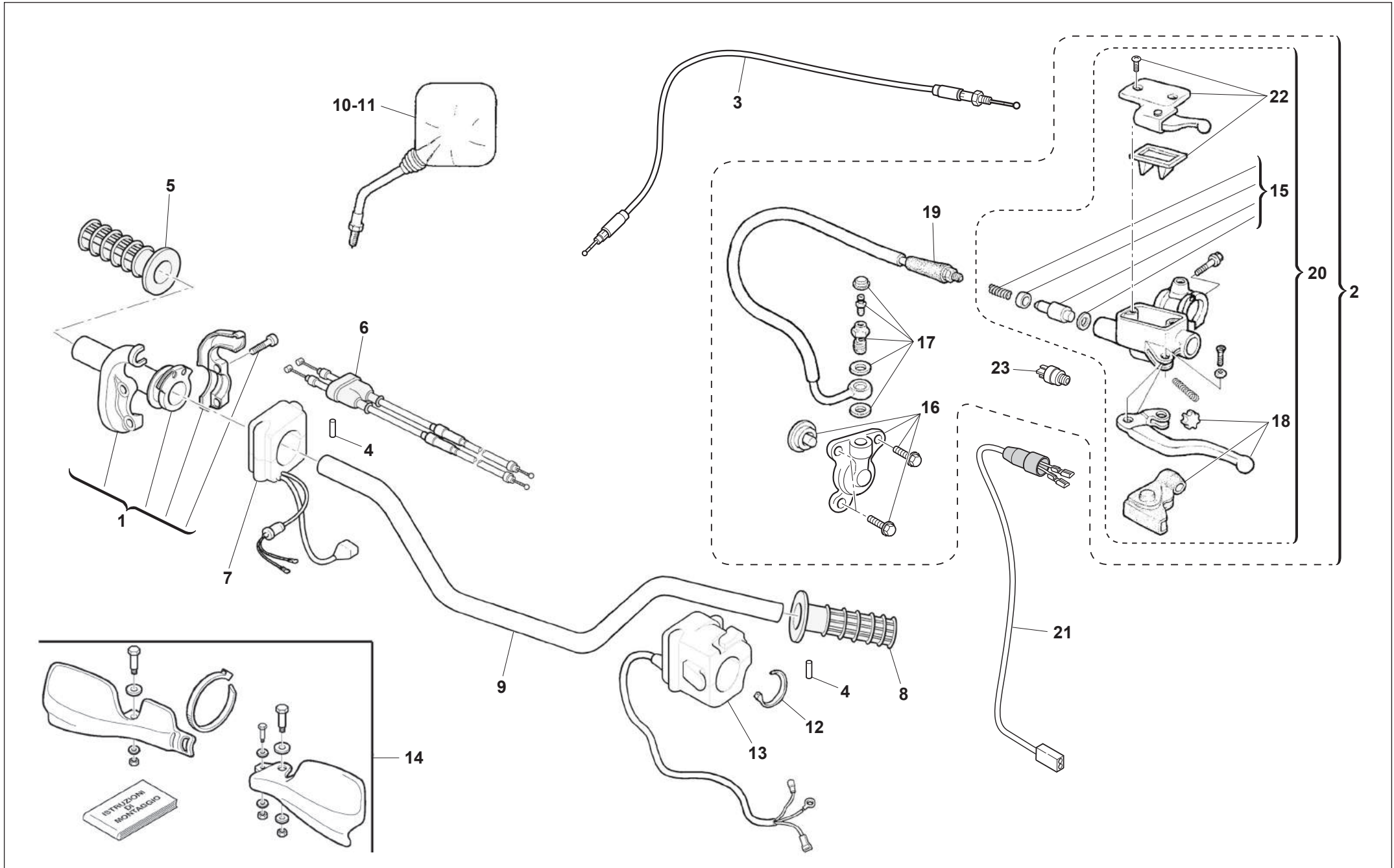

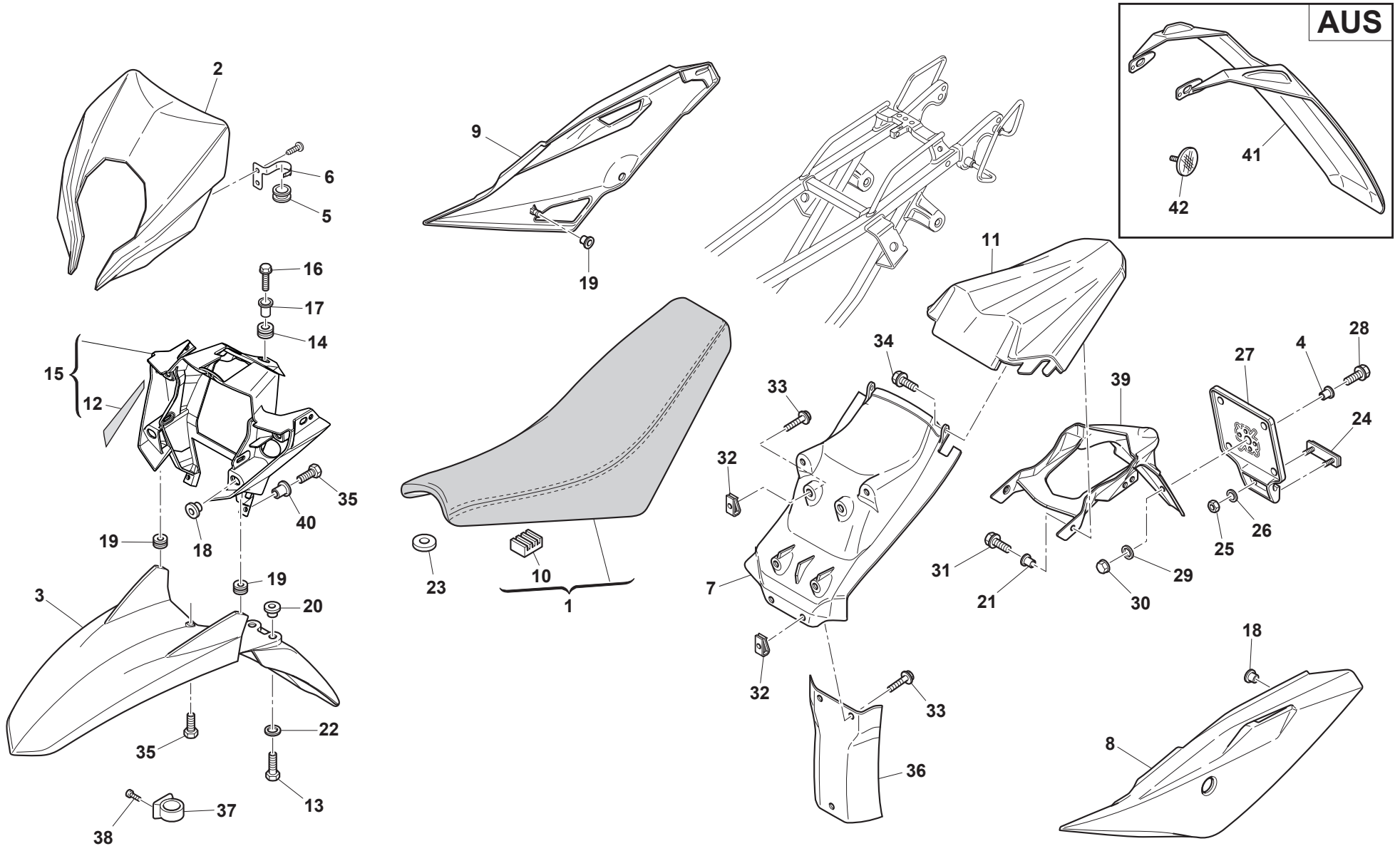

**RS-SM 650R/2016**
**PANNELLI, PARAFANGHI, SELLA - PANEL, FENDERS, SEAT
 PANNEAU, GARDE-BOUES, SIEGE - STREIFEN, KOTFLUGEL, SATTEL
 PANELO, GUARDABARROS, SILLIN**
TAVOLA
DRAWING
TABLE
BILD
TABLA**22**

Note Notes Notes Marke Notas	Pos. No. N. Index Pos.	N. Cod. Code No. Nr. Code Code Nr N. Cod.	Q.tà Q.ty Q.te M.ge C.ad	DENOMINAZIONE	NAME	DESIGNATION	BESHREIBUNG	DENOMINACION
	1	F000A00077	1	SELLA	SEAT	SELLE	SITZBANK	ASIENTO
	2	F000A00416	1	CUPOLINO	COWLING	CAPOT	KOPFVERKLEIDUNG	CUPULA
SM 650R	3	80C0A4711	1	PARAFANGO ANTERIORE	FENDER, FRONT	GARDE BOUE AVANT	KOTFLUEGEL VORNE	GUARDABARROS DELANTERO
RS 650R	3	80C0H1987	1	PARAFANGO ANTERIORE	FENDER, FRONT	GARDE BOUE AVANT	KOTFLUEGEL VORNE	GUARDABARROS DELANTERO
	4	800069282	2	BOCCOLA 14X7X5,25 MM	BUSH 14X7X5.25 MM	DOUILLE 14X7X5,25 MM	BUCHSE 14X7X5,25 MM	CASQUILLO 14X7X5,25 MM
	5	800071806	1	GOMMINO	GROMMET	CAOUTCHOUC	GUMMITEILE	GOMA
	6	800071807	1	PIASTRINA	PLATE	PLAQUE	PLATTE	PLACA
	7	8000H1268	1	PARAFANGO POSTERIORE INTERNO	FENDER REAR, INNER	GARDE-BOUE ARRIERE INTERIEUR	KOTFLUEGEL HINTEN, INNERER	GUARDABARROS TRASERO INTERIOR
	8	F000P00211	1	FIANCHETTO SINISTRO	COVER, FRAME LH	COUVERCLE CADRE GAUCHE	SEITENDECKEL, LINKS	CUBIERTA BASTIDOR IZQUERDA
	9	F000P00212	1	FIANCHETTO DESTRO	COVER, FRAME RH	COUVERCLE CADRE DROIT	SEITENDECKEL, RECHTS	CUBIERTA BASTIDOR DERECHA
	10	86610191A	4	TAMPONE IN GOMMA	CUSHION RUBBER	TAMPON EN CAOUTCHOUC	GUMMISTOPFEN	TAMPON GOMA
SM 650R	11	80C0H1269	1	PARAFANGO POSTERIORE	FENDER, REAR	GARDE-BOUE ARRIERE	KOTFLUEGEL HINTEN	GUARDABARROS TRASERO
RS 650R	11	80C0H1989	1	PARAFANGO POSTERIORE	FENDER, REAR	GARDE-BOUE ARRIERE	KOTFLUEGEL HINTEN	GUARDABARROS TRASERO
	12	8000H2416	1	DECAL DESTRO	DECAL RH	DECAL DROIT	DECAL RECHTS	DECAL DERECHA
	12	8000H2417	1	DECAL SINISTRO	DECAL LH	DECAL GAUCHE	DECAL LINKS	DECAL IZQUERDA
	13	Z00062727	4	VITE TE M6X1X16 CH8	SCREW TE M6X1X16 CH8	VIS TE M6X1X16 CH8	SCHRAUBE TE M6X1X16 CH8	TORNILLO TE M6X1X16 CH8
	14	8000H3250	4	GOMMINO	GROMMET	CAOUTCHOUC	GUMMITEILE	GOMA
	15	8000H2415	1	SUPPORTO FANALE ANTERIORE	STAY, HEADLIGHT	SUPPORT FEU AVANT	KONSOLE, SCHEINWERFER	SOPORTE FARO DELANTERO
	16	8A00A8423	2	VITE FLANGIATA M6X12	BOLT, FLANGE M5X12	VIS A EMBASE M5X12	GEFLANSCHSCHRAUBE M5X12	TORNILLO CON VALONA M5X12
	17	8000H3251	1	BOCCOLA	BUSH	DOUILLE	BUCHSE	BUJE
	18	800041874	6	GOMMINO 24X13X9	GROMMET 24X13X9	CAOUTCHOUC 24X13X9	GUMMITEILE 24X13X9	GOMA 24X13X9
	19	800095128	2	GOMMINO	GROMMET	CAOUTCHOUC	GUMMITEILE	GOMA
SM 650R	20	ZC0069429	4	BOCCOLA	BUSH	DOUILLE	BUCHSE	BUJE
RS 650R	20	Z00069429	6	BOCCOLA 9X7X4,8	BUSH 9X7X4.8	DOUILLE 9X7X4,8	BUCHSE 9X7X4,8	BUJE 9X7X4,8
	21	ZC0069429	4	BOCCOLA	BUSH	DOUILLE	BUCHSE	BUJE
	22	Z00048814	4	RONDELLA 18X6,4X2	WASHER 18X6.4X2	RONDELLE 18X6,4X2	SCHEIBE 18X6,4X2	ARANDELA 18X6,4X2
	23	8A00H2959	1	RONDELLA IN GOMMA	WASHER, RUBBER	RONDELLE EN CAOUTCHOUC	GUMMISCHEIBE	ARANDELA GOMA
	24	800073834	1	CATADIOTTRO POSTERIORE	REFLEX REFLECTOR, REAR	CATADIOPTRE ARRIERE	RUECKSTRAHLER	CATAFARO TRASERO
	25	Z00040717	1	DADO	NUT	ECROU	MUTTER	TUERCA
	26	62N115547	2	RONDELLA	WASHER 12X4.3X0.8	RONDELLE 12X4,3X0,8	SCHEIBE 12X4,3X0,8	ARANDELA 12X4,3X0,8
	27	8000H3018	1	PIASTRA PORTATARGA	BRACKET, LICENSE PLATE	PORTE-PLAQUE IMMATRICULATION	KONSOLE, KENNZEICHEN	PORTA-MATRICULA
	28	Z00067997	2	VITE TEF M5X0,8X12	SCREW TEF M5X0,8 CH8	VIS TEF M5X0,8 CH8	SCHRAUBE TEF M5X0,8 CH8	TORNILLO TEF M5X0,8 CH8
	29	62ND15547	2	RONDELLA	WASHER 12X4.3X0.8	RONDELLE 12X4,3X0,8	SCHEIBE 12X4,3X0,8	ARANDELA 12X4,3X0,8

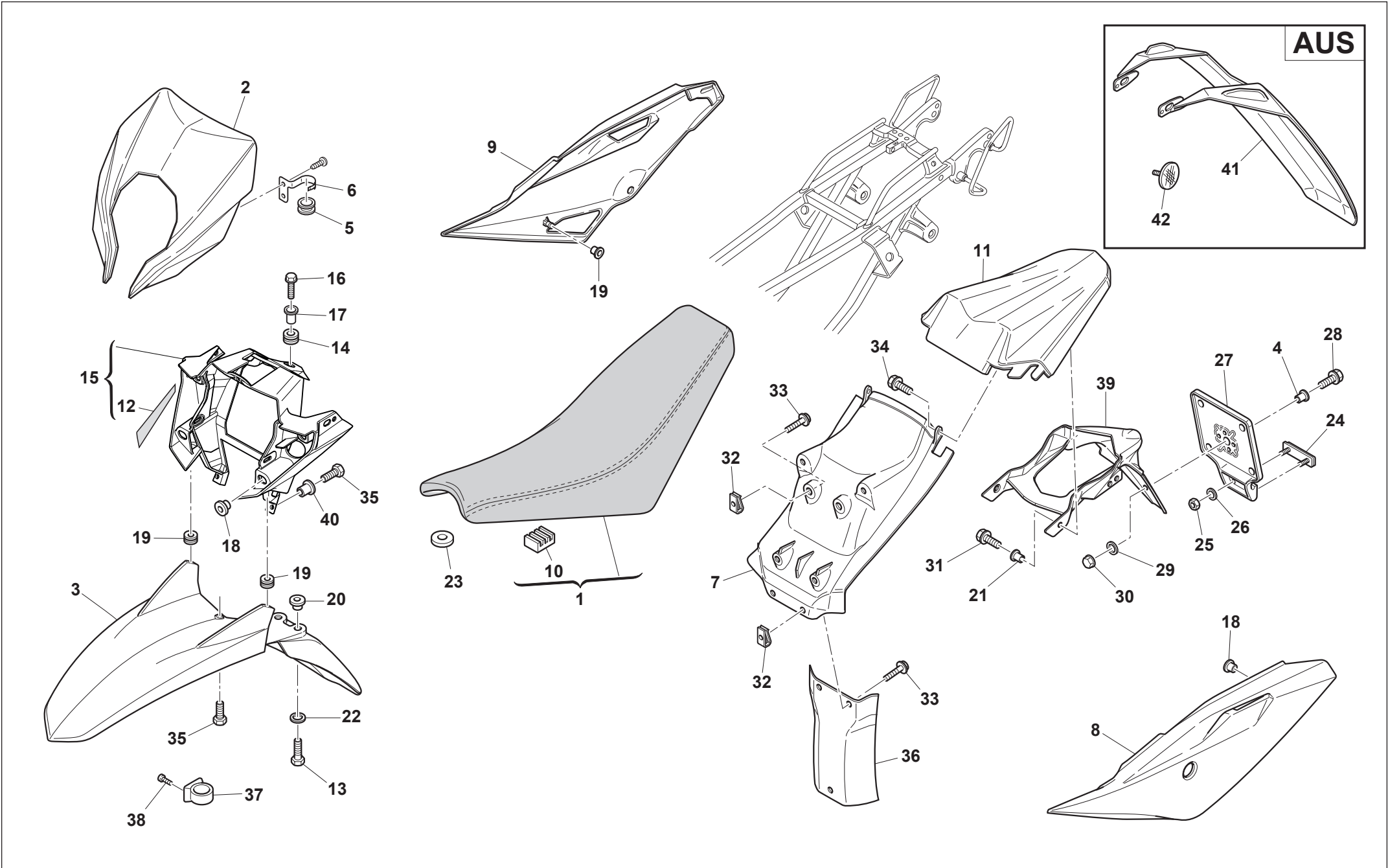

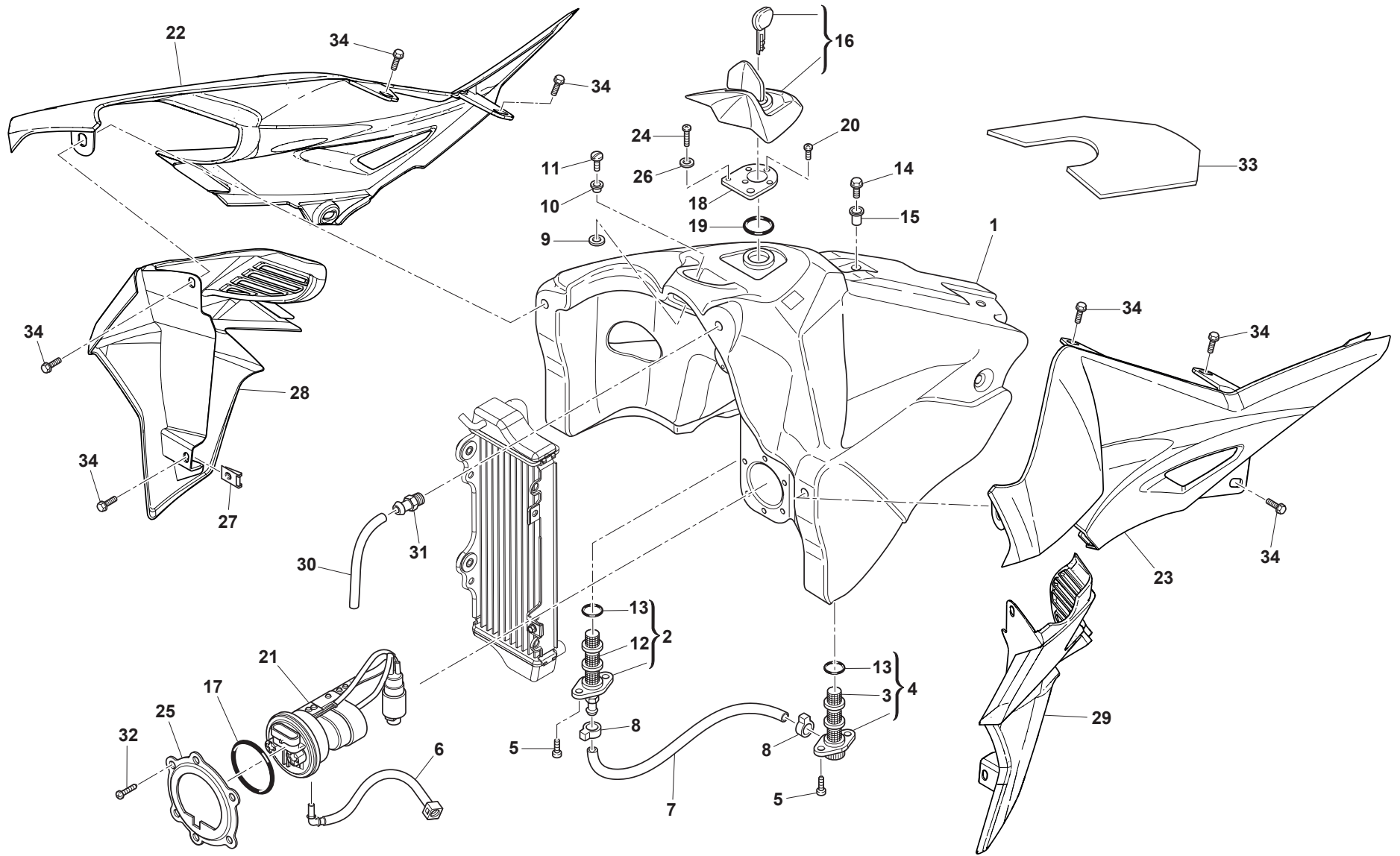

**SERBATOIO CARBURANTE, CONVOGLIATORI - GAS TANK, PANEL -
RESERVOIR CARBURANT, FLANC - KRAFTSTOFFBEHALTER, FLANKE -
DEPOSITO GASOLINA, LATERAL**

Note Notes Notas	Pos. No. Index Pos.	N. Cod. Code No. Nr. Code Code Nr N. Cod.	Q.tà Q.ty M.ge C.ad	DENOMINAZIONE	NAME	DESIGNATION	BESHREIBUNG	DENOMINACION
	1	8A00H1183	1	SERBATOIO CARBURANTE	FUEL TANK	RESERVOIR CARBURANT	KRAFTSTOFFTANK	DEPOSITO CARBURANTE
	2	8000A8283	1	RUBINETTO CARBURANTE DESTRO	FUEL COCK, RH	ROBINET ESSENCE DROIT	KRAFTSTOFFHAHN, RECHTS	GRIFO GASOLINA DERECHO
	3	800067700	1	FILTRO CARBURANTE	FILTER, FUEL	FILTRE CARBURANT	KRAFTSTOFFFILTER	FILTRO CARBURANTE
	4	800067440	1	RUBINETTO CARBURANTE SINISTRO	FUEL COCK, LH	ROBINET ESSENCE GAUCHE	KRAFTSTOFFHAHN, LINKS	GRIFO GASOLINA IZQUERDO
	5	Z00037745	4	VITE TC1C AUTOFILETTANTE 5,5X19	SCREW SELF-TAPPING TC1C 5.5X19	VIS TARAUD TC1C 5,5X19	GEWINDESCHRAUBE TC1C 5,5X19	TORNILLO AUTOROSCANTE TC1C 5,5X19
	6	8000H2403	1	TUBO CARBURANTE ALTA PRESSIONE	HOSE, FUEL HIGH PRESSURE	TUYAU CARBURANT HAUTE PRESSION	KRAFTSTOFFSCHLAUCH HOCHDRUCK	TUBO CARBURANTE ALTA PRESION
	7	8E0094010	1	TUBO CARBURANTE 280 MM	HOSE. FUEL 280 MM	TUYAU CARBURANT 280 MM	KRAFTSTOFFSCHLAUCH 280 MM	TUBO CARBURANTE 280 MM
	8	8E0095276	2	FASCETTA	CLAMP	COLLIER	KLAMMER	ABRAZADERA
	9	800061362	3	RONDELLA 27X12X5 MM	WASHER 27X12X5 MM	RONDELLE 27X12X5 MM	SCHEIBE 27X12X5 MM	ARANDELA 27X12X5 MM
	10	8000A5678	1	RONDELLA PIANA	WASHER, PLAIN	RONDELLE, PLATE	UNTERLEGSCHNEIBE	ARANDELA PLANA
	11	60ND07335	1	VITE TCEI M6X1,00X16	SCREW TCEI M6X1,00X16	VIS TCEI M6X1,00X16	SCHRAUBE TCEI M6X1,00X16	TORNILLO TCEI M6X1,00X16
	12	8000A8284	1	FILTRO RUBINETTO CARBURANTE	SCREEN FUEL STRAINER	FILTRE CARBURANT	KRAFTSTOFFFILTER	FILTRO CARBURANTE
	13	8000A8278	2	ANELLO O-RING 2X11	O-RING 2X11	JOINT TORIQUE 2X11	O-RING 2X11	JUNTA TORICA 2X11
	14	60ND04134	1	VITE TSCI M6X1,00X20	SCREW TSCI M6X1,00X20	VIS TSCI M6X1,00X20	SCHRAUBE TSCI M6X1,00X20	TORNILLO TSCI M6X1,00X20
	15	800066238	1	DISTANZIALE 20X10X6,5X12 MM	SPACER 20X10X6,5X12 MM	ENTRETOISE 20X10X6,5X12 MM	ABSTANDHALTER 20X10X6,5X12 MM	DISTANCIADOR 20X10X6,5X12 MM
	16	F000A00193	1	TAPPO SERBATOIO CARBURANTE	CAP SET, FUEL TANK	BOUCHON RESERVOIR CARBURANT	VERSCHLUSS, KRAFTSTOFFTANK	TAPON DEPOSITO CARBURANTE
	17	8C00H1186	1	GUARNIZIONE POMPA CARBURANTE	GASKET, FUEL PUMP	JOINT POMPE A ESSENCE	DICHTUNG, KRAFTSTOFFPUMPE	JUNTA BOMBA GASOLINA
	18	8000A7409	1	FLANGIA TAPPO SERBATOIO CARBURANTE	COLLAR, FUEL CAP	ENCADREMENT BOUCHON RESERVOIR CARBURANT	RING KRAFTSTOFFOLTANKVERSCHLUSS	CERCO TAPON DEPOSITO GASOLINA
	19	8A00A9701	1	GUARNIZIONE	GASKET	JOINT	DICHTUNG	JUNTA
	20	ZA0059572	4	VITE TSEI M5X0,8X12	SCREW TSEI M5X0,8X12	VIS TSEI M5X0,8X12	SCHRAUBE TSEI M5X0,8X12	TORNILLO TSEI M5X0,8X12
	21	8000H1184	1	POMPA CARBURANTE	PUMP, FUEL	POMPE CARBURANT	KRAFTSTOFFPUMPE	BOMBA CARBURANTE
	22	F000P00188	1	CONVOGLIATORE DESTRO	COVER, RADIATOR, RH	OUIE RADIATEUR DROIT	RECHTES LEITBLECH	PROTECTOR RADIADOR DERECHO
	23	F000P00187	1	CONVOGLIATORE SINISTRO	COVER, RADIATOR, LH	OUIE RADIATEUR GAUCHE	LINKES LEITBLECH	DEFLECTOR AIRE IZQUERDO
	24	ZC0061070	1	VITE TTEI M6X1,00X10	SCREW TTEI M6X1,00X10	VIS TTEI M6X1,00X10	SCHRAUBE TTEI M6X1,00X10	TORNILLO TTEI M6X1,00X10
6 FORI	25	8A00H1185	1	FLANGIA POMPA CARBURANTE	BRACKET, FUEL PUMP	BRIDE POMPE CARBURANT	FLANSCH, KRAFTSTOFFPUMPE	BRIDA BOMBA CARBURANTE
	26	62N015673	1	RONDELLA IN ALLUMINIO 11X6,1X1	WASHER, ALUMINIUM 11X6,1X1	RONDELLE EN ALUMINIUM 11X6,1X1	ALUMINIUM SCHEIBE 11X6,1X1	ARANDELA DE ALUMINIO 11X6,1X1
	27	U00046893	1	DADO M6X1	NUT M6X1	ECROU M6X1	MUTTER M6X1	TUERCA M6X1
	28	F000P00136	1	PROTEZIONE RADIATORE DESTRO	COVER, RADIATOR, RH	OUIE RADIATEUR DROIT	RECHTES LEITBLECH	PROTECTOR RADIADOR DERECHO
	29	F000P00135	1	PROTEZIONE RADIATORE SINISTRO	COVER, RADIATOR, LH	OUIE RADIATEUR GAUCHE	LINKES LEITBLECH	PROTECTOR RADIADOR IZQUERDO
	30	8N0068873	1	TUBO IN GOMMA 730 MM	HOSE, RUBBER 730 MM	TUYAU EN CAOUTCHOUC 730 MM	GUMMISCHLAUCH 730 MM	MANGUERA GOMA 730 MM
	31	8000A4031	1	RACCORDO FILETTATO	THREADED NIPPLE	RACCORD FILETEE	HOHLSCHRAUBE	EMPALME ROSCADO
	32	ZH0067545	6	VITE TEF M6X1,00X14 CH8	SCREW TEF M6X1,00X14 CH8	VIS TEF M6X1,00X14 CH8	SCHRAUBE TEF M6X1,00X14 CH8	TORNILLO TEF M6X1,00X14 CH8
	33	8000A6430	1	ISOLANTE TERMICO	HEAT SHIELD	ISOLATEUR THERMIQUE	WAERMSCHUTZ	AISILANTE ATERMICO

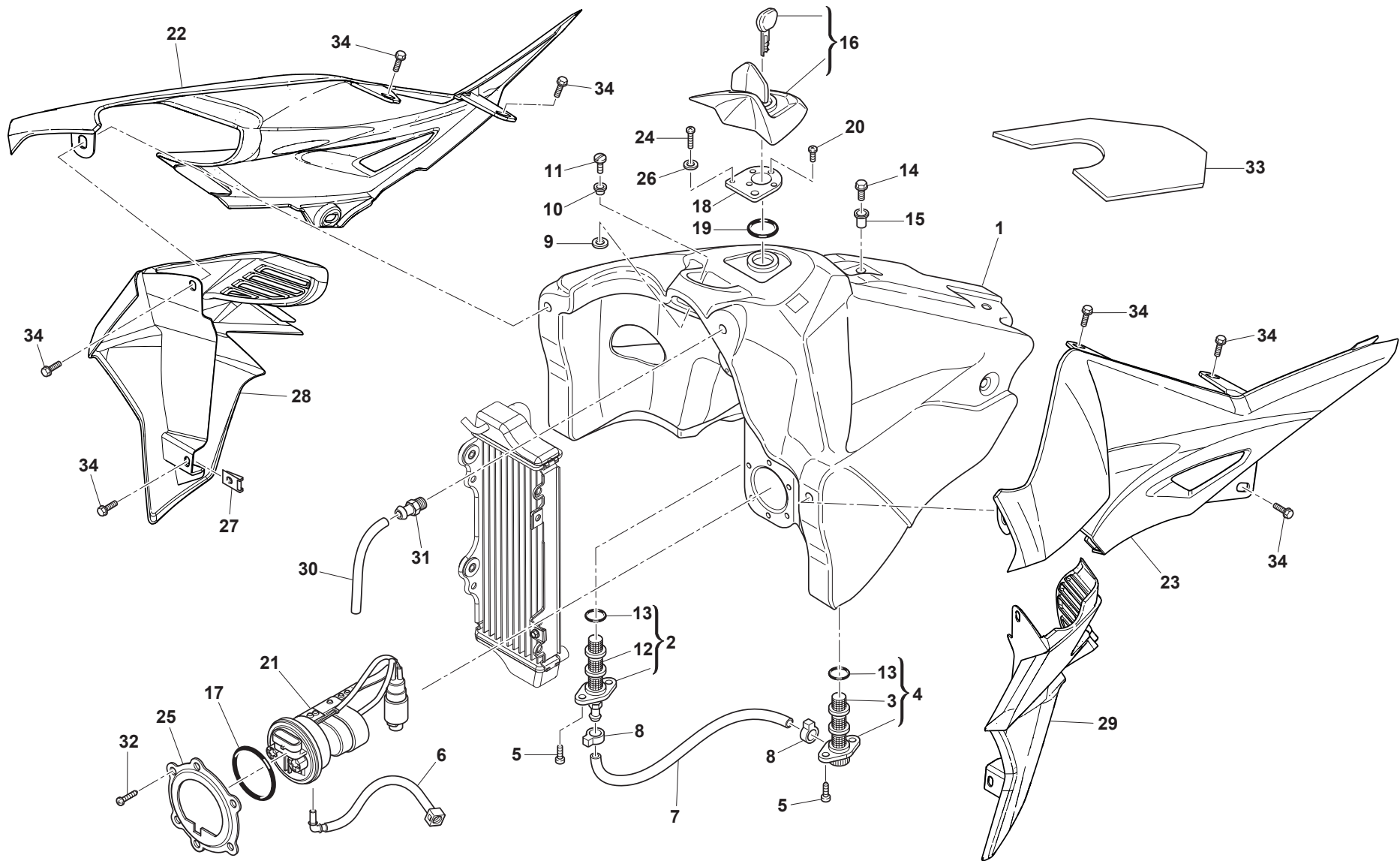

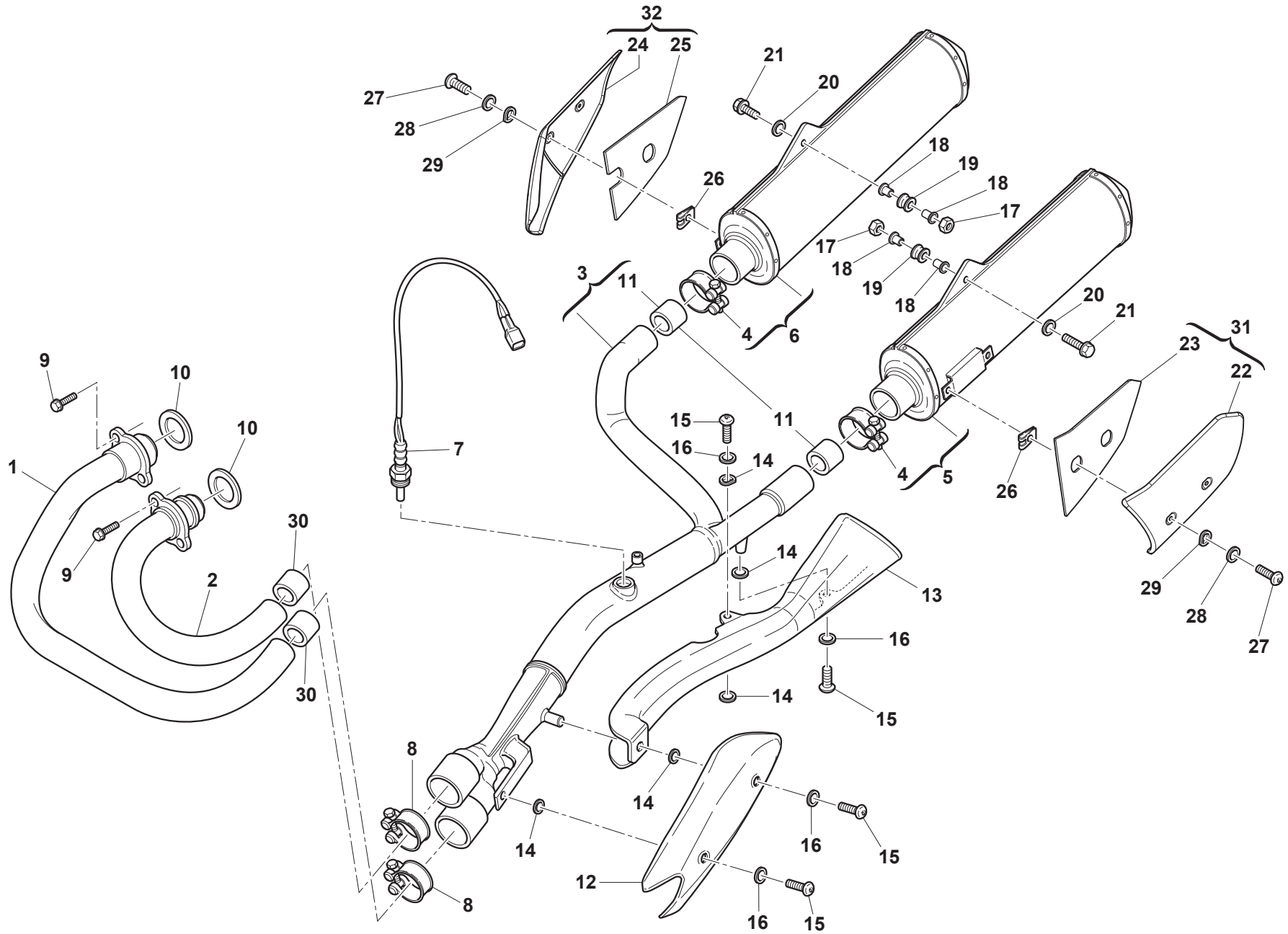



RS-SM 650R/2016

SCARICO - EXHAUST SYSTEM TUYAU D'ÉCHAPPEMENT - AUSPUFFROHR TUBO DE ESCAPE

TAVOLA
DRAWING
TABLE
BILD
TABLA

24

Note Notes Notas	Pos. No. N. Index Pos.	N. Cod. Code No. Nr. Code Code Nr N. Cod.	Q.tà Q.ty Q.te M.ge C.ad	DENOMINAZIONE	NAME	DESIGNATION	BESHREIBUNG	DENOMINACION
	1	F000P00611	1	COLLETTORE SCARICO DESTRO	PIPE, EXHAUST RH	TUYAU ECHAPPEMENT DROIT	RECHTES AUSPUFFROHR	TUBERIA ESCAPE DERECHO
	2	F000P00612	1	COLLETTORE SCARICO SINISTRO	PIPE EXHAUST LH	TUYAU ECHAPPEMENT GAUCHE	LINKS AUSPUFFKRUEMMER	TUBERIA ESCAPE IZQUERDO
	3	F000P00613	1	TUBO SCARICO	EXHAUST PIPE	TUYAU ECHAPPEMENT	AUSPUFFROHR	TUBERIA ESCAPE
	4	8000H2219	2	FASCETTA	CLAMP	COLLIER	KLAMMER	ABRAZADERA
	5	F000P00467	1	SILENZIATORE SINISTRO	SILENCER, LEFT	SILENCIEUX GAUCHE	SCHALLDAEMPFER, LINKS	SILENCIADOR IZQUERDO
	6	F000P00468	1	SILENZIATORE DESTRO	SILENCER, RH	SILENCIEUX DROIT	SCHALLDAEMPFER, RECHTS	SILENCIADOR DERECHO
	7	F000P00579	1	SENSORE OSSIGENO	SENSOR, OXYGEN	CAPTEUR OXYGENE	ABTASTER SAUERSTOFF	SENSOR OXYGENO
	8	8000H2220	2	FASCETTA	CLAMP	COLLIER	KLAMMER	ABRAZADERA
	9	60ND02509	4	VITE TCEI M6X1X20 CH5	SCREW TCEI M6X1X20 CH5	VIS TCEI M6X1X20 CH5	SCHRAUBE TCEI M6X1X20 CH5	TORNILLO TCEI M6X1X20 CH5
	10	8A00A0873	2	GUARNIZIONE SCARICO	GASKET, EXHAUST PIPE	JOINT TUYAU ECHAPPEMENT	DICHTUNG, AUSPUFFROHR	JUNTA TUBERIA ESCAPE
	11	8000H1864	2	GUARNIZIONE SILENZIATORE	GASKET, SILENCER	JOINT SILENCIEUX	DICHTUNG SCHALLDAEMPFER	JUNTA SILENCIADOR
	12	F000P00071	1	PROTEZIONE COLLETTORE SCARICO	COVER, EXHAUST PIPE	PROTECTION TUYAU ECHAPPEMENT	AUSPUFFROHRSCHUTZ	PROTECCION TUBERIA ESCAPE
	13	F000P00072	1	PROTEZIONE COLLETTORE SCARICO	COVER, EXHAUST PIPE	PROTECTION TUYAU ECHAPPEMENT	AUSPUFFROHRSCHUTZ	PROTECCION TUBERIA ESCAPE
	14	800035112	4	RONDELLA ISOLANTE 14X5,5X2 MM	INSULATING WASHER 14X5,5X2 MM	RONDELLE ISOLANTE 14X5,5X2 MM	ISOLIERSCHEIBE 14X5,5X2 MM	ARANDELA AISLANTE 14X5,5X2 MM
	15	Z00055703	4	VITE TCEI M6X1,00X14	SCREW TCEI M6X1,00X14	VIS TCEI M6X1,00X14	SCHRAUBE TCEI M6X1,00X14	TORNILLO TCEI M6X1,00X14
	16	62N115778	4	RONDELLA 12X6,4X0,5	WASHER 12X6,4X0,5	RONDELLE 12X6,4X0,5	SCHEIBE 12X6,4X0,5	ARANDELA 12X6,4X0,5
	17	Z00044240	2	DADO AUTOBLOCCANTE M6X1 CH10	NUT, SELF LOCKING M6X1 CH10	ECROU AUTOBLOQUANT M6X1 CH10	SELBSTSPERRENDE MUTTER M6X1 CH10	TUERCA AUTOBLOQUEANTE M6X1 CH10
	18	8C00A7729	4	DISTANZIALE	SPACER	ENTRETOISE	ABSTANDHALTER	DISTANCIADOR
	19	800089302	2	SILENTBLOCK	DAMPER	SILENTBLOC	SCHWINGUNGSDAEMPFER	CASQUILLO ELASTICO
	20	800022271	4	RONDELLA 20X6,4X1,5	WASHER 20X6,4X1,5	RONDELLE 20X6,4X1,5	SCHEIBE 20X6,4X1,5	ARANDELA 20X6,4X1,5
	21	ZE0067545	2	VITE TEF M6X1,00X40 CH8	SCREW TEF M6X1,00X40 CH8	VIS TEF M6X1,00X40 CH8	SCHRAUBE TEF M6X1,00X40 CH8	TORNILLO TEF M6X1,00X40 CH8
	22	F000P00073	1	PROTEZIONE SILENZIATORE SINISTRO	COVER, LEFT MUFFLER	PROTECTION SILENCIEUX GAUCHE	AUSPUFFROHRSCHUTZ, LINKS	PROTECCION SILENCIADOR IZQUERDO
	23	F000P00074	1	ISOLANTE TERMICO	HEAT SHIELD	ISOLATEUR THERMIQUE	WAERMSCHUTZ	AISILANTE ATERMICO
	24	F000P00075	1	PROTEZIONE SILENZIATORE DESTRO	COVER, RH MUFFLER	PROTECTION SILENCIEUX DROIT	AUSPUFFROHRSCHUTZ, RECHTS	PROTECCION SILENCIADOR DERECHO
	25	F000P00076	1	ISOLANTE TERMICO	HEAT SHIELD	ISOLATEUR THERMIQUE	WAERMSCHUTZ	AISILANTE ATERMICO
	26	U00046893	7	DADO ELASTICO M6X1	CLIP NUT M6X1	JONC M6X1	KLEMME M6X1	PREASIENTO M6X1
	27	800055703	4	VITE TCEI M6X1,00X14	SCREW TCEI M6X1,00X14	VIS TCEI M6X1,00X14	SCHRAUBE TCEI M6X1,00X14	TORNILLO TCEI M6X1,00X14
	28	62N115778	4	RONDELLA 12X6,4X0,5	WASHER 12X6,4X0,5	RONDELLE 12X6,4X0,5	SCHEIBE 12X6,4X0,5	ARANDELA 12X6,4X0,5
	29	800035112	4	RONDELLA ISOLANTE 14X5,5X2 MM	INSULATING WASHER 14X5,5X2 MM	RONDELLE ISOLANTE 14X5,5X2 MM	ISOLIERSCHEIBE 14X5,5X2 MM	ARANDELA AISLANTE 14X5,5X2 MM
	30	8000H1864	2	GUARNIZIONE SCARICO	GASKET, EXHAUST PIPE	JOINT TUYAU ECHAPPEMENT	DICHTUNG, AUSPUFFROHR	JUNTA TUBERIA ESCAPE
	31	F000A00771	1	PROTEZIONE SILENZIATORE SX COMPL.	COVER, LH MUFFLER ASSY	PROTECTION SILENCIEUX G. COMPL.	AUSPUFFROHRSCHUTZ, LINKS KOMPL.	PROTECCION SILENCIADOR IZQ. COMPL.
	32	F000A00772	1	PROTEZIONE SILENZIATORE DX COMPL.	COVER, RH MUFFLER ASSY	PROTECTION SILENCIEUX D. COMPL.	AUSPUFFROHRSCHUTZ, RECHTS KOMPL.	PROTECCION SILENCIADOR DER. COMPL.

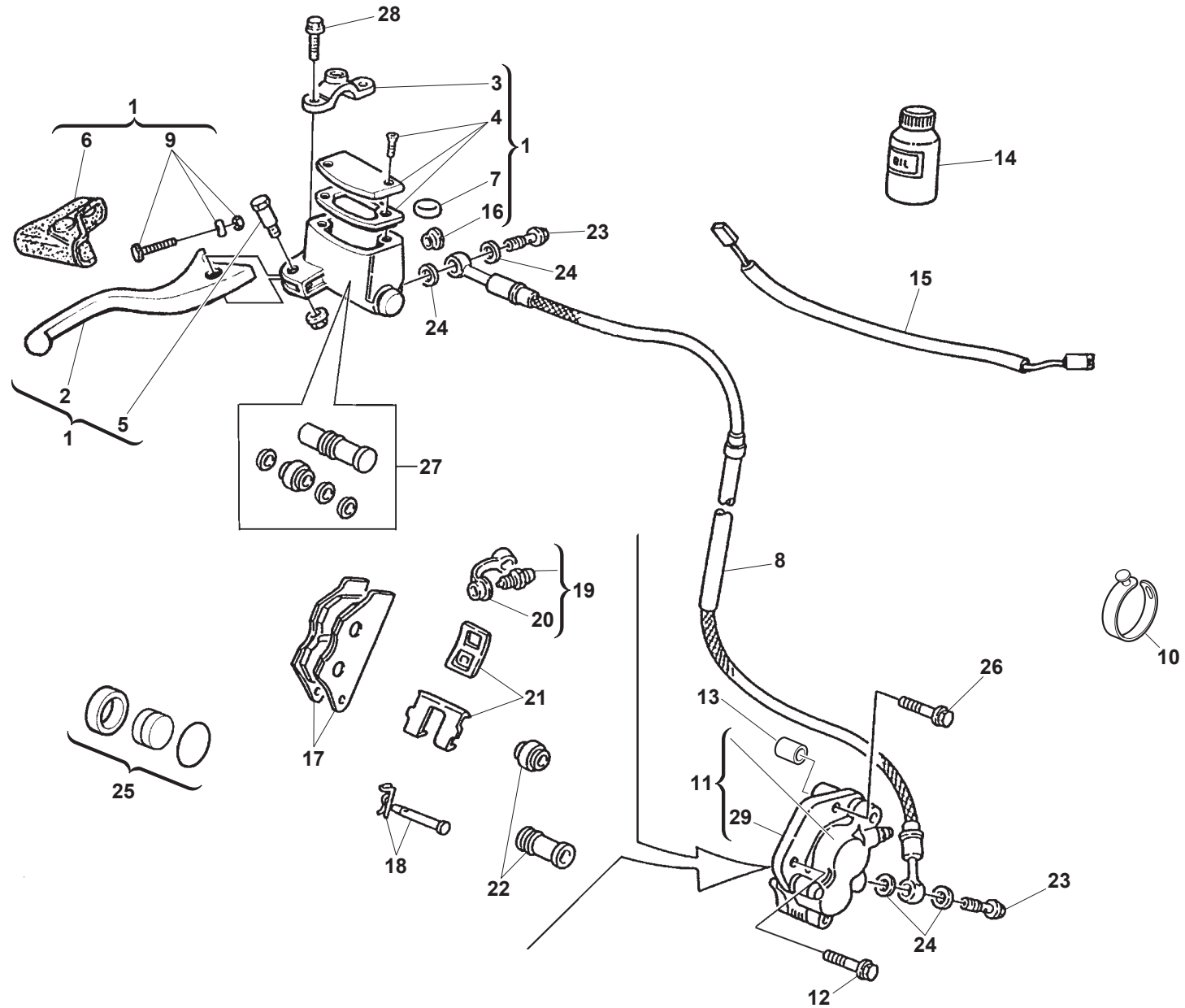

**RS 650R/2016**

FRENO IDRAULICO ANTERIORE - FRONT HYDRAULIC BRAKE
FREIN HYDRAULIQUE AVANT - VORDERBREMSE
FRENO HIDRAULICO DELANTERO

TAVOLA
DRAWING
TABLE
BILD
TABLA

25

Note Notes Notas	Pos. No. Index Pos.	N. Cod. Code No. Nr. Code Code Nr N. Cod.	Q.tà Q.ty Q.te M.ge C.ad	DENOMINAZIONE	NAME	DESIGNATION	BESHREIBUNG	DENOMINACION
	1	8000A9348	1	POMPA FRENO ANTERIORE	CYLINDER, FRONT MASTER	MAITRE CYLINDRE FREIN AVANT	HAUPTZYLINDER, VORNE	BOMBA FRENO DELANTERO
	2	8000A4564	1	LEVA FRENO ANTERIORE	LEVER, FRONT BRAKE	LEVIER FREIN AVANT	BREMSHEBEL VORNE	PALANCA FRENO DELANTERO
	3	8000A4568	1	CAVALLOTTO POMPA FRENO	BRACKET, MASTER CYLINDER	BRIDE MAITRE CYLINDRE	KONSOLE, HAUPTBREMSZYLINDER	BRIDA BOMBA FRENO
	4	800094126	1	COPERCHIO VASCHETTA LIQUIDO FRENI	COVER MASTER CYLINDER	COUVERCLE RESERVOIR LIQUIDE FREIN	VERSCHLUSS BREMSFLUESSIGKEITANK	TAPON DEPOSITO LIQUIDO FRENOS
	5	800094127	1	PERNO LEVA FRENO	BOLT, HANDLE LEVER PIVOT	PIVOT LEVIER FREIN	HEBELSCHRAUBE KPL.	PERNO PALANCA FRENO
	6	800094128	1	SOFFIETTO POMPA FRENO	DUST COVER	SOUFFLET EN CAOUTCHOUC	GUMMIBALG	FUELLE GOMA
	7	800079099	1	ANTIEMULSIONANTE	ANTIEMULSION	ANTIEMULSION	EMULSIONWIDRIGER	ANTIEMULSION
	8	F000P00570	1	TUBO FRENO ANTERIORE	HOSE, FRONT BRAKE	TUYAU FREIN AVANT	BREMSSCHLAUCH VORNE	MANGUERA FRENO DELANTERO
	9	8000A9349	1	VITE REGISTRO LEVA	ADJUSTING SCREW	VIS REGLAGE	EINSTELLSCHRAUBE	TORNILLO REGULACION
	10	800092247	4	FASCETTA IN GOMMA 62MM	CLAMP, RUBBER 62MM	COLLIER CAOUTCHOUC 62MM	GUMMIBAND 62MM	BANDA DE GOMA 62MM
	11	800099674	1	PINZA FRENO ANTERIORE	CALIPER, FRONT BRAKE	ETRIER FREIN AVANT	BREMSSATTEL, VORNE	PINZA FRENO DELANTERO
	12	ZA0062733	1	VITE TE M8X1,25X40	SCREW TE M8X1,25X40	VIS TE M8X1,25X40	SCHRAUBE TE M8X1,25X40	TORNILLO TE M8X1,25X40
	13	8000A5987	2	BOCCOLA	BUSH	DOUILLE	BUCHSE	BUJE
	14	A000P00720	1	LIQUIDO FRENI	BRAKE FLUID	LIQUIDE FREIN	BREMSFLUESSIGKEIT	LIQUIDO FRENO
	15	8000A0929	1	INTERRUTTORE STOP	SWITCH, STOP	INTERRUPTEUR STOP	STOPSCHALTER	INTERRUPTOR STOP
	16	800049654	1	VETRINO SPIA LIVELLO OLIO	WINDOW, OIL LEVEL CHECK	HUBLOT NIVEAU HUILE	SCHAUGLAS, OELKONTROLL	MIRILLA NIVEL ACEITE
	17	800096934	1	COPPIA PASTIGLIE FRENO ANTERIORE	PADS SET, FRONT BRAKE	JEU PLAQUETTES FREIN AVANT	VORNEBREMSBELAEGESATZ	JUEGO PASTILLAS FRENO DELANTERO
	18	8000A0932	1	GRUPPO REVISIONE PERNI PASTIGLIE FRENO	PAD PINS OVERHAUL SET	GROUPE REVISION PIVOTS PLAQUETTE	BREMSBELAEGEN EBERHOLUNGSGRUPPE	GRUPO REVISION PERNO PASTILLAS FRENO
	19	8000A0931	1	VITE SPURGO PINZA FRENO	BLEED SCREW KIT	VIS VIDANGE ETRIER FREIN	SCHRAUBE, BREMSSATTEL ABLASS	TORNILLO PURGA PINZA FRENO
	20	800053259	1	CAPPUCCIO VITE SPURGO	CAP, BLEEDER SCREW	CAPUCHON VIS RENIFLARD	ENTLUEFTUNGSKAPPE	CAPUCHON TORNILLO PURGA PINZA
	21	800079065	1	MOLLETTE PASTIGLIE FRENO	SUPPORT, PAD	RESSORT PLAQUETTE FREIN	FEDER, BREMSSESHEIBE	MUELLE PASTILLAS
	22	800079066	1	SERIE SILENTBLOCK PINZA FRENO	CAPS OVERHAUL SET	GROUPE REVISION CAPOUCHONS	GUMMIUBERARBAITUNGSZAZ	GRUPO REVISION GORRO
	23	U00057155	2	VITE RACCORDO TUBO M10X1,00X19	BOLT, BRAKE HOSE M10X1,00X19	VIS FIXATION TUYAU M10X1,00X19	FIXIERSCHRAUBE M10X1,00X19	TORNILLO FIJACION MANGUERA M10X1,00X19
	24	800021480	4	RONDELLA 14X10,2X1 MM	WASHER 14X10,2X1 MM	RONDELLE 14X10,2X1 MM	SCHEIBE 14X10,2X1 MM	ARANDELA 14X10,2X1 MM
	25	8000A0930	1	PISTONCINO PINZA FRENO	PISTON, CALIPER	PISTON ETRIER FREIN	KOLBEN BREMSSATTEL	PISTON PINZA FRENO
	26	ZB0062733	1	VITE	SCREW	VIS	SCHRAUBE	TORNILLO
	27	8000A9350	1	PISTONCINO POMPA FRENO	CYLINDER KIT, MASTER	PISTON MAITRE CYLINDRE	KOLBEN, BREMSEPUMPE	PISTON BOMBA FRENO
	28	Z00062729	2	VITE TEF M6X1X25 CH8	SCREW TEF M6X1X25 CH8	VIS TEF M6X1X25 CH8	SCHRAUBE TEF M6X1X25 CH8	TORNILLO TEF M6X1X25 CH8
	29	800099859	1	SUPPORTO PINZA FRENO ANTERIORE	CARRIER SET, FR BRAKE	SUPPORT ETRIER FREIN AVANT	HALTERUNG, VORNEBREMSSESATTEL	SOPORTE PINZA FRENO DELANTERO

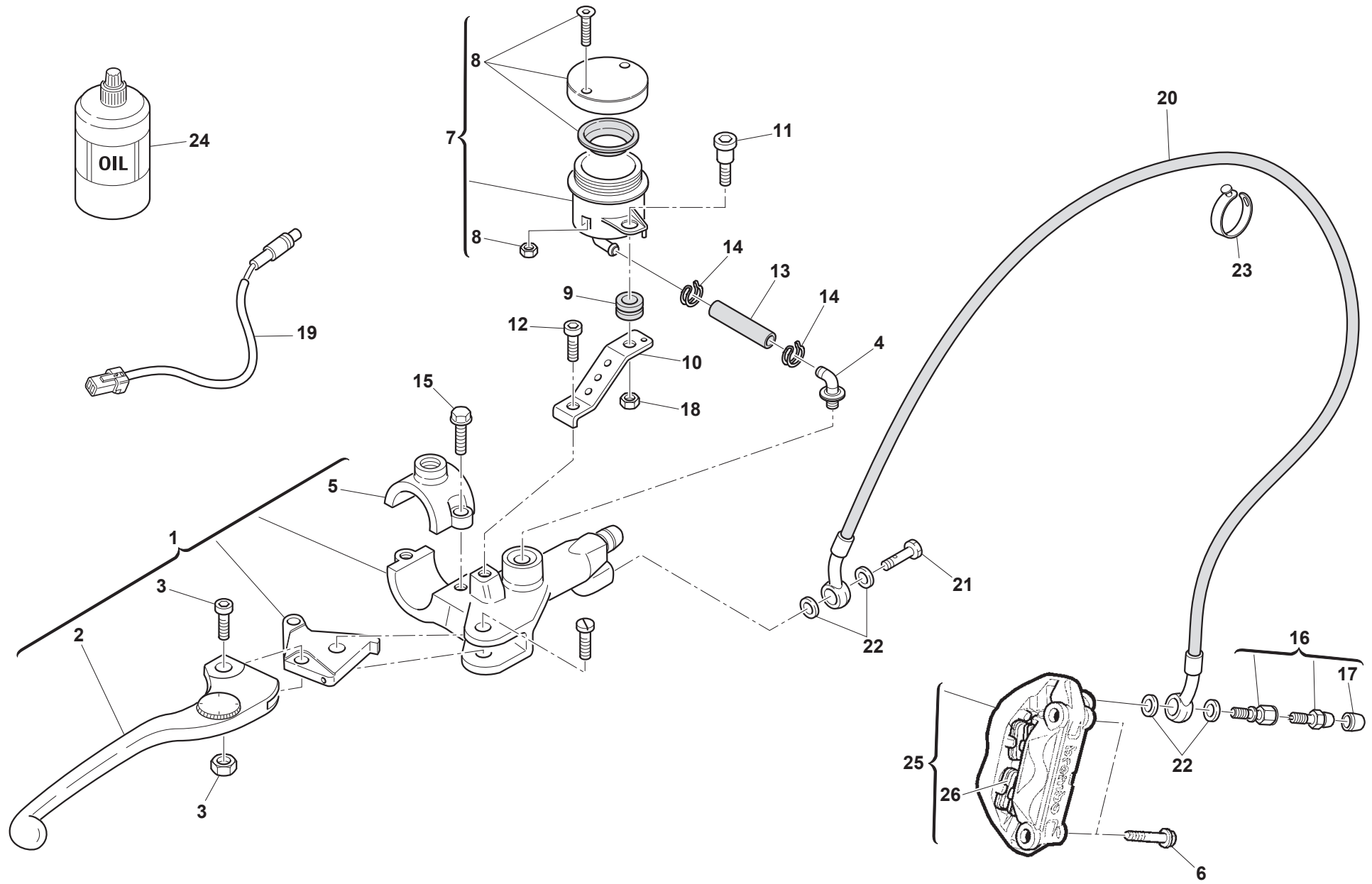



SM 650R/2015

FRENO IDRAULICO ANTERIORE - FRONT HYDRAULIC BRAKE
FREIN HYDRAULIQUE AVANT - VORDERBREMSE
FRENO HIDRAULICO DELANTERO

TAVOLA
DRAWING
TABLE
BILD
TABLA

25A

Note Notes Notes Marke Notas	Pos. No. N. Index Pos.	N. Cod. Code No. Nr. Code Code Nr N. Cod.	Q.tà Q.ty Q.te M.ge C.ad	DENOMINAZIONE	NAME	DESIGNATION	BESHREIBUNG	DENOMINACION
	1	8000A6076	1	POMPA FRENO ANTERIORE	CYLINDER, FRONT MASTER	MAITRE CYLINDRE FREIN AVANT	HAUPTZYLINDER, VORNE	BOMBA FRENO DELANTERO
	2	8000A7146	1	LEVA FRENO ANTERIORE	LEVER, FRONT BRAKE	LEVIER FREIN AVANT	BREMSHEBEL VORNE	PALANCA FRENO DELANTERO
	3	8000A7148	1	GRUPPO REVISIONE PERNO LEVA	LEVER PIN SET	GROUPE REVISION PIVOT LEVIER	HEBELBOLZENGRUPPE	GRUPO REVIS. PERNO PALANCA
	4	800042345	1	RACCORDO TUBO	UNION, HOSE	JOINT TUYAU	VERBINDUNG, SCHLAUCH	RACOR MANGUITO
	5	8000A7147	1	CAVALLOTTO POMPA FRENO	BRACKET, MASTER CYLINDER	BRIDE MAITRE CYLINDRE	KONSOLE, HAUPTBREMSZYLINDER	BRIDA BOMBA FRENO
	6	YS0082751	2	VITE TCEIF M10X1,25X55	SCREW TCEIF M10X1.25X55	VIS TCEIF M10X1,25X55	SCHRAUBE TCEIF M10X1,25X55	TORNILLO TCEIF M10X1,25X55
	7	800066181	1	VASCHETTA LIQUIDO FRENI	RESERVOIR, BRAKE FLUID	RESERVOIR LIQUIDE FREINS	BREMSFLUESSIGKEITTANK	DEPOSITO LIQUIDO FRENO
	8	800068490	1	TAPPO VASCHETTA LIQUIDO FRENI	CAP BRAKE FLUID TANK	BOUCHON RESERVOIR LIQUIDE FREIN	VERSCHLUSS BREMSFLUESSIGKEITTANK	TAPON DEPOSITO LIQUIDO FRENO
	9	800033288	1	SILENTBLOCK 20X10X13	DAMPER 20X10X13	SILENTBLOC 20X10X13	SCHWINGSDAEMPFER 20X10X13	CASQUILLO ELASTICO 20X10X13
	10	8000A6229	1	PIASTRINA	PLATE	PLAQUETTE	PLAETTCHEN	PLETINA
	11	8000A1189	1	VITE TTEI M5X16	SCREW TTEI M5X16	VIS TTEI M5X16	SCHRAUBE TTEI M5X16	TORNILLO TTEI M5X16
	12	Z00062725	1	VITE TEF M6X1,00X10 CH8	SCREW TEF M6X1.00X10 CH8	VIS TEF M6X1,00X10 CH8	SCHRAUBE TEF M6X1,00X10 CH8	TORNILLO TEF M6X1,00X10 CH8
	13	8G0066179	1	TUBO OLIO	HOSE, OIL	TUYAU HUILE	OELSCHLAUCH	MANGUERA ACEITE
	14	800018921	2	ANELLO ELASTICO 10 MM	CIRCLIP 10 MM	BAGUE ELASTIQUE 10 MM	SPRENGRING 10 MM	ANILLO ELASTICO 10 MM
	15	Z00062729	2	VITE TEF M6X1X25 CH8	SCREW TEF M6X1X25 CH8	VIS TEF M6X1X25 CH8	SCHRAUBE TEF M6X1X25 CH8	TORNILLO TEF M6X1X25 CH8
	16	8000A3975	1	VITE RACCORDO TUBO OLIO	BOLT, OIL PIPE	VIS FIXATION TUYAU HUILE	FIXIERSCHRAUBE OELSCHLAUCH	TORNILLO FIJACION TUBO ACEITE
	17	800053259	1	CAPPUCCIO VITE SPURGO	CAP, BLEEDER SCREW	CAPUCHON VIS RENIFLARD	ENTLUEFTUNGSKAPPE	CAPUCHON TORNILLO PURGA PINZA
	18	Z00056443	1	DADO AUTOBLOCCANTE M5X0,8 CH8	NUT, SELF LOCKING M5X0.8 CH8	ECROU AUTOBLOQUANT M5X0,8 CH8	SELBSTSPERRENDE MUTTER M5X0,8 CH8	TUERCA AUTOBLOQUEANTE M5X0,8 CH8
	19	8000A0929	1	INTERRUPTORE STOP	SWITCH, STOP	INTERRUPTEUR STOP	STOPSCHALTER	INTERRUPTOR STOP
	20	8A00A1706	1	TUBO FRENO ANTERIORE	HOSE, FRONT BRAKE	TUYAU FREIN AVANT	VORDERBREMSSCHLAUCH	MANGUERA FRENO DELANTERO
	21	U00057155	1	VITE RACCORDO TUBO M10X1,00X19	BOLT, BRAKE HOSE M10X1.00X19	VIS FIXATION TUYAU M10X1,00X19	FIXIERSCHRAUBE M10X1,00X19	TORNILLO FIJACION MANGUERA M10X1,00X19
	22	800021480	4	RONDELLA 14X10,2X1 MM	WASHER 14X10.2X1 MM	RONDELLE 14X10,2X1 MM	SCHEIBE 14X10,2X1 MM	ARANDELA 14X10,2X1 MM
	23	800092247	4	FASCETTA	CLAMP	COLLIER	KLAMMER	ABRAZADERA
	24	A000P00720	1	LIQUIDO FRENI	BRAKE FLUID	LIQUIDE FREIN	BREMSFLUESSIGKEIT	LIQUIDO FRENO
	25	8000A6078	1	PINZA FRENO ANTERIORE	CALIPER, FRONT BRAKE	ETRIER FREIN AVANT	BREMSSATTEL, VORNE	PINZA FRENO DELANTERO
	26	8A00A2040	1	COPIA PASTIGLIE FRENO ANTERIORE	PADS SET, FRONT BRAKE	JEU PLAQUETTES FREIN AVANT	VORNEBREMSBELAEGESATZ	JUEGO PASTILLAS FRENO DELANTERO

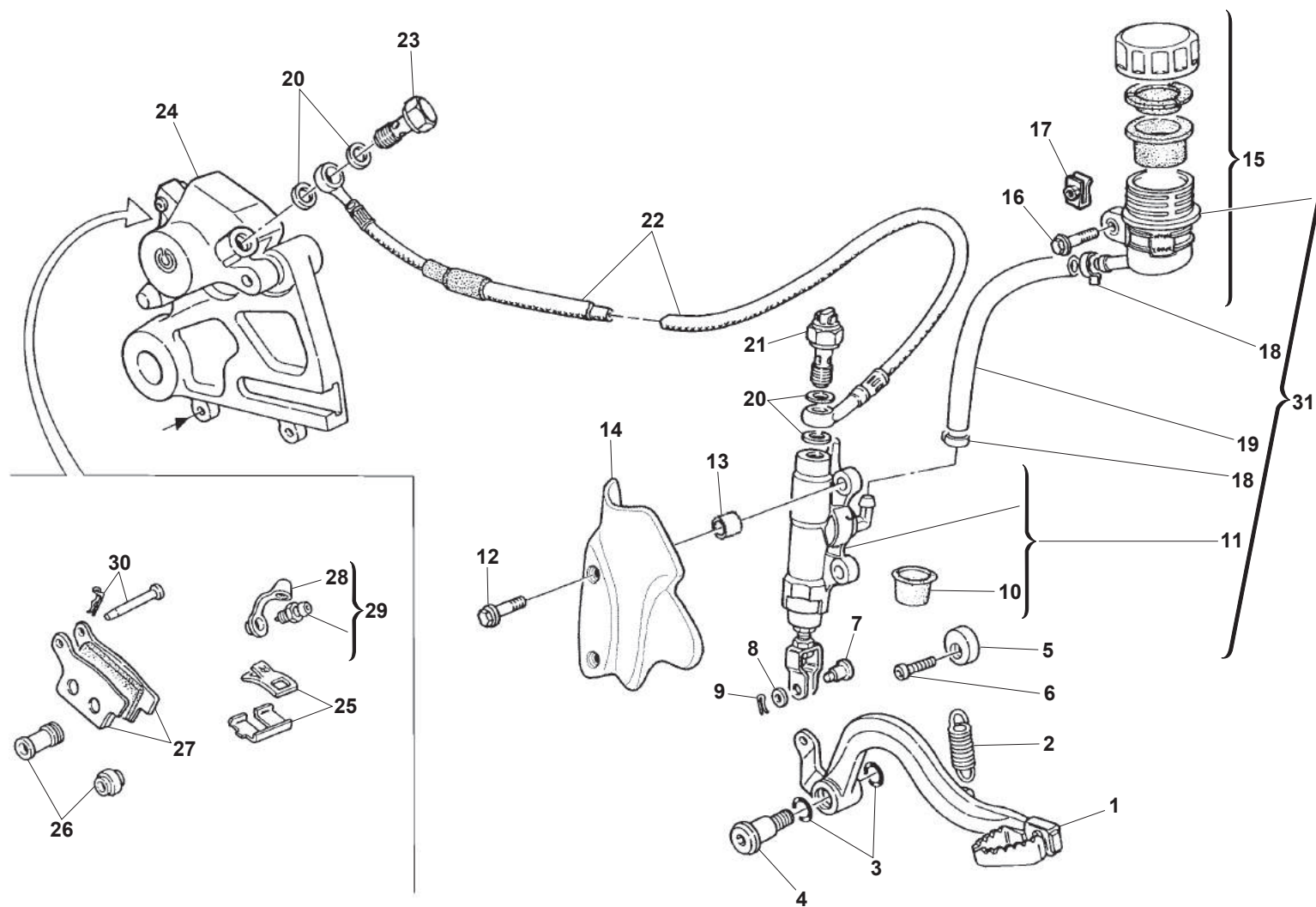



RS-SM 650R/2016

FRENO IDRAULICO POSTERIORE - REAR HYDRAULIC BRAKE
FREIN HYDRAULIQUE ARRIERE - HINTERBREMSE
FRENO HIDRAULICO TRASERO

TAVOLA
DRAWING
TABLE
BILD
TABLA

26

Note Notes Notes Marke Notas	Pos. No. N. Index Pos.	N. Cod. Code No. Nr. Code Code Nr N. Cod.	Q.tà Q.ty Q.te M.ge C.ad	DENOMINAZIONE	NAME	DESIGNATION	BESHREIBUNG	DENOMINACION
	1	800085958	1	PEDALE FRENO	PEDAL, BRAKE	PEDALE FREIN	FUSSBREMSPEDAL	PEDAL FRENO
	2	800055903	1	MOLLA PEDALE FRENO	SPRING, BRAKE PEDAL	RESSORT PEDALE FREIN	FEDER, BREMSPEDAL	MUELLE PEDAL FRENO
	3	800022551	2	ANELLO O-RING 2056 14X1,78	O-RING 2056 14X1.78	JOINT TORIQUE 2056 14X1,78	O-RING 2056 14X1,78	JUNTA TORICA 2056 14X1,78
	4	Y00055902	1	VITE TPEI M10X1,25X16	SCREW TPEI M10X1.25X16	VIS TPEI M10X1,25X16	SCHRAUBE TPEI M10X1,25X16	TORNILLO TPEI M10X1,25X16
	5	8A0069125	1	ECCENTRICO PEDALE FRENO	ECCENTRIC, ADJUSTMENT BRAKE PEDAL	EXCENTRIQUE REGLAGE PEDAL FREIN	REGULIEREXZENTIKER BREMSE PEDAL	EXCENTRICO REGULACION PEDAL FRENO
	6	Y00055241	1	VITE TSEI M6X1X14 CH5	SCREW TSEI M6X1X14 CH5	VIS TSEI M6X1X14 CH5	SCHRAUBE TSEI M6X1X14 CH5	TORNILLO TSEI M6X1X14 CH5
	7	800070696	1	PERNO FORCELLINA POMPA 8X20	PIN 8X20	PIVOT 8X20	BOLZEN 8X20	PERNO 8X20
	8	Z00056377	1	RONDELLA 16X8,3X1	WASHER 16X8.3X1	RONDELLE 16X8,3X1	SCHEIBE 16X8,3X1	ARANDELA 16X8,3X1
	9	64ND20068	1	COPIGLIA 18X1,8	SPLIT PIN 18X1.8	GOUPILLE 18X1,8	SPLINT 18X1,8	CLAVIJA 18X1,8
	10	800079075	1	CUFFIA	BOOT	COIFFE	HAUBE	GORRO
	11	800076338	1	POMPA FRENO POSTERIORE	CYLINDER, REAR MASTER	MAITRE CYLINDRE FREIN ARRIERE	HAUPTZYLINDER, HINTEN	BOMBA FRENO TRASERO
	12	Z00062728	2	VITE TEF M6X1X20 CH8	SCREW TEF M6X1X20 CH8	VIS TEF M6X1X20 CH8	SCHRAUBE TEF M6X1X20 CH8	TORNILLO TEF M6X1X20 CH8
	13	Z00069429	2	BOCCOLA 9X7X4,8	BUSH 9X7X4.8	DOUILLE 9X7X4,8	BUCHSE 9X7X4,8	BUJE 9X7X4,8
	14	8000A5583	1	PROTEZIONE POMPA FRENO	GUARD, MASTER CYLINDER	PROTECTION POMPE ARRIERE	HINTERPUMPESCHUTZ	PROTECCION BOMBA FRENO
	15	800061078	1	VASCHETTA LIQUIDO FRENI POSTERIORE	RESERVOIR, BRAKE FLUID REAR	RESERVOIR LIQUIDE FREINS ARRIERE	BREMSFLUESSIGKEITTANK, HINTEN	DEPOSITO LIQUIDO FRENO TRASERO
	16	Z00062727	1	VITE TE M6X1X16 CH8	SCREW TE M6X1X16 CH8	VIS TE M6X1X16 CH8	SCHRAUBE TE M6X1X16 CH8	TORNILLO TE M6X1X16 CH8
	17	U00046893	1	DADO ELASTICO M6X1	CLIP NUT M6X1	JONC M6X1	KLEMME M6X1	PREASIENTO M6X1
	18	800042349	2	FASCETTA	CLAMP	COLLIER	KLAMMER	ABRAZADERA
	19	8L0066179	1	TUBO IN GOMMA 6,5X10,5X300	HOSE, RUBBER 6.5X10.5X300	TUYAU EN CAOUTCHOUC 6,5X10,5X300	GUMMISCHLAUCH 6,5X10,5X300	TUBO DE GOMA 6,5X10,5X300
	20	800021480	4	RONDELLA 14X10,2X1 MM	WASHER 14X10.2X1 MM	RONDELLE 14X10,2X1 MM	SCHEIBE 14X10,2X1 MM	ARANDELA 14X10,2X1 MM
	21	800094849	1	INTERRUTTORE STOP POSTERIORE	SWITCH, REAR BRAKE	INTERRUPTEUR STOP ARRIERE	HINTEN STOPSCHALTER	INTERRUPTOR STOP TRASERO
	22	8000A0665	1	TUBO FRENO POSTERIORE	HOSE, REAR BRAKE	TUYAU FREIN ARRIERE	BREMSSCHLAUCH HINTEN	MANGUERA FRENO TRASERO
	23	U00057155	1	VITE RACCORDO TUBO M10X1,00X19	BOLT, BRAKE HOSE M10X1.00X19	VIS FIXATION TUYAU M10X1,00X19	FIXIERSCHRAUBE M10X1,00X19	TORNILLO FIJACION MANGUERA M10X1,00X19
	24	F000A00315	1	PINZA FRENO POSTERIORE	CALIPER, REAR BRAKE	ETRIER FREIN ARRIERE	HINTEN BREMSSELTEL	PINZA FRENO TRASERA
	25	800085932	1	MOLLETTE PASTIGLIE FRENO	SUPPORT, PAD	RESSORT PLAQUETTE FREIN	FEDER, BREMSSESHEIBE	MUELLE PASTILLAS
	26	800079066	1	SERIE SILENTBLOCK PINZA FRENO	CAPS OVERHAUL SET	GROUPE REVISION CAPOUCHONS	GUMMIUBERARBAITUNGSZAZ	GRUPO REVISION GORRO
	27	8000A9231	1	COPPIA PASTIGLIE FRENO POSTERIORE	PADS SET, REAR BRAKE	JEU PLAQUETTES FREIN ARRIERE	HINTERBREMSBELAEGESATZ	JUEGO PASTILLAS FRENO TRASERO
	28	800053259	1	CAPPUCCIO VITE SPURGO	CAP, BLEEDER SCREW	CAPUCHON VIS RENIFLARD	ENTLUEFTUNGSKAPPE	CAPUCHON TORNILLO PURGA PINZA
	29	8000A0931	1	VITE SPURGO PINZA FRENO	BLEED SCREW KIT	VIS VIDANGE ETRIER FREIN	SCHRAUBE, BREMSSELTEL ABLASS	TORNILLO PURGA PINZA FRENO
	30	8000A0933	1	GRUPPO REVISIONE PERNI PASTIGLIE	PAD PINS OVERHAUL SET	GROUPE REVISION PIVOTS PLAQUETTE	BREMSBELAEGEN EBERHOLUNGSGRUPPE	GRUPO REVISION PERNO PASTILLAS FRENO
	31	8A0076026	1	POMPA FRENO POSTERIORE	CYLINDER, REAR MASTER	MAITRE CYLINDRE FREIN ARRIERE	HAUPTZYLINDER, HINTEN	BOMBA FRENO TRASERO

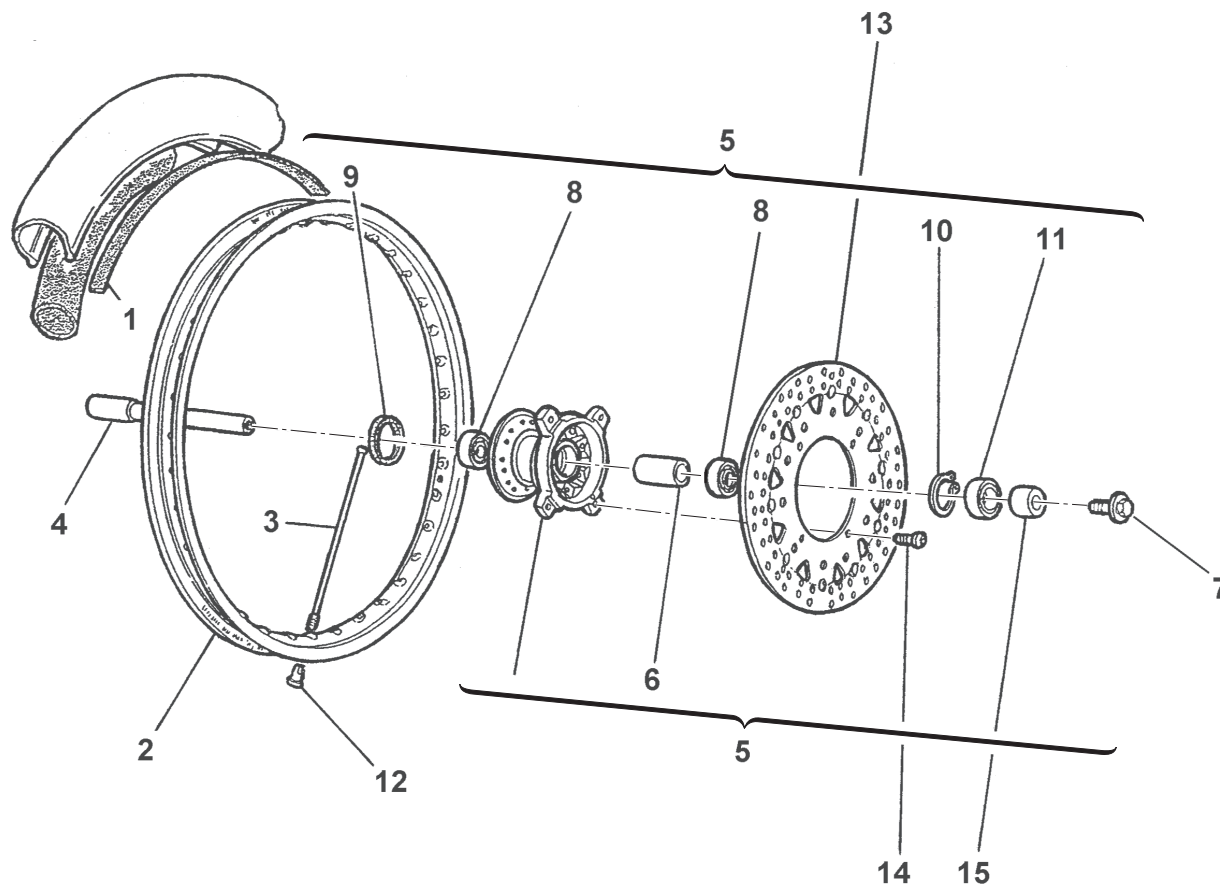



SM 650R/2015

RUOTA ANTERIORE - FRONT WHEEL ROUE AV. - VORTERRAD RUEDA DELANTERA

TAVOLA
DRAWING
TABLE
BILD
TABLA

Note Notes Notas	Pos. No. Index Pos.	N. Cod. Code No. Nr. Code Code Nr N. Cod.	Q.tà Q.ty Q.te M.ge C.ad	DENOMINAZIONE	NAME	DESIGNATION	BESHREIBUNG	DENOMINACION
	1	8B0082879	1	FASCIA SALVACAMERA	PROTECTOR, INNER TUBE	FOND JANTE	FELGENBAND	PROTECTOR CAMARA
	2	F000P00261	1	CERCHIO RUOTA ANTERIORE 3,5X17	RIM, FRONT WHEEL 3,5X17	JANTE ROUE AVANT 3,5X17	FELGE, VORDERRAD 3,5X17	LLANTA RUEDA DELANTERA 3,5X17
	3	8000H1724	36	RAGGIO RUOTA ANTERIORE	SPOKE	RAYON	SPEICHE	RADIO
	4	FB00P00058	1	PERNO RUOTA ANTERIORE	AXE, FRONT WHEEL	AXE ROUE AVANT	VORDERRADACHSE	EJE RUEDA DELANTERA
	5	FA00A00091	1	MOZZO RUOTA ANTERIORE	HUB, FRONT WHEEL	MOYEU ROUE AVANT	RADNABE, VORNE	CUBO RUEDA DELANTERA
	6	F000P00120	1	DISTANZIALE INTERNO CUSCINETTI	SPACER, HUB BEARING	ENTRETOISE INTERNE ROULEMENT	KUGELLAGER INNEREABSTANDHALTER	DISTANCIADOR INTERIOR COJINETE
	7	800096933	1	VITE M20	SCREW M20	VIS M20	SCHRAUBE M20	TORNILLO M20
	8	800084938	2	CUSCINETTO A SFERE 25X42X9	BEARING, BALL 25X42X9	ROULEMENT A BILLES 25X42X9	KUGELLAGER 25X42X9	COJINETE DE BOLAS 25X42X9
	9	8000H6187	1	PARAOLIO 28X50X5	OIL SEAL 28X50X5	BAGUE D'ETANCHEITE 28X50X5	WELLENDICHTRING 28X50X5	RETEN DE ACEITE 28X50X5
	10	66N021270	1	ANELLO SEEGER INTERNO 42MM DIN472	CIRCLIP 42MM DIN472	CIRCLIP 42MM DIN472	SEEGERRING 42MM DIN472	ANILLO SEEGER 42MM DIN472
	11	800022966	1	PARAPOLVERE 32X42X7	SEAL, DUST 32X42X7	PARE POUSSIERE 32X42X7	STAUBDECKEL 32X42X7	GUARDAPOLVO 32X42X7
	12	69N429004	36	NIPPLO RAGGIO	NIPPLE, SPOKE	ECROU RAYON	NIPPEL, SPEICHE	TUERCA RADIO
	13	8000H1391	1	DISCO FRENO ANTERIORE	DISC, FRONT BRAKE	DISQUE FREIN AVANT	BREMSSCHEIBE, VORNE	DISCO FRENO DELANTERO
	14	YA0092876	4	VITE TTEI M8X1,25X16	SCREW TTEI M8X1,25X16	VIS TTEI M8X1,25X16	SCHRAUBE TTEI M8X1,25X16	TORNILLO TTEI M8X1,25X16
	15	8A0096930	1	DISTANZIALE	SPACER	ENTRETOISE	ABSTANDHALTER	DISTANCIADOR

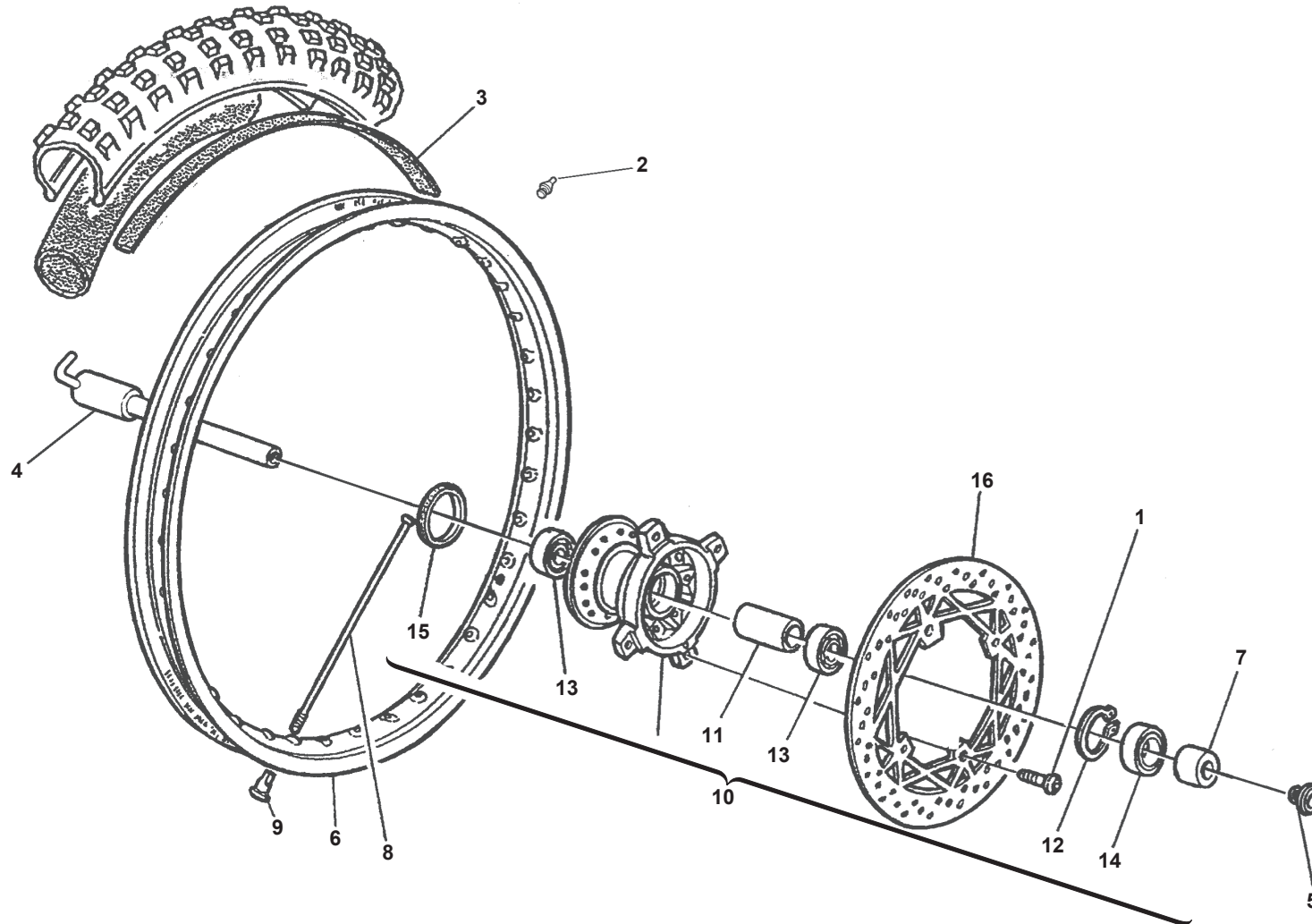



RS 650R/2016

RUOTA ANTERIORE - FRONT WHEEL
ROUE AV. - VORTERRAD
RUEDA DELANTERA

TAVOLA
 DRAWING
 TABLE
 BILD
 TABLA

27A

Note Notes Marke Notas	Pos. No. Index Pos.	N. Cod. Code No. Nr. Code Code Nr N. Cod.	Q.tà Q.ty Q.te M.ge C.ad	DENOMINAZIONE	NAME	DESIGNATION	BESHREIBUNG	DENOMINACION
	1	YA0055241	4	VITE TCEI M6X1X14 CH5	SCREW TCEI M6X1X14 CH5	VIS TCEI M6X1X14 CH5	SCHRAUBE TCEI M6X1X14 CH5	TORNILLO TCEI M6X1X14 CH5
	2	80009570	1	TAMPONE IN GOMMA 9,2X8,5X6X15	RUBBER PAD 9.2X8.5X6X15	TAMPON EN CAOUTCHOUC 9,2X8,5X6X15	GUMMISTOPFEN 9,2X8,5X6X15	PUNZON GOMA 9,2X8,5X6X15
	3	800013346	1	FASCIA SALVACAMERA	PROTECTOR, INNER TUBE	FOND JANTE	FELGENBAND	PROTECTOR CAMARA
	4	F000P00058	1	PERNO RUOTA ANTERIORE	AXE, FRONT WHEEL	AXE ROUE AVANT	VORDERRADACHSE	EJE RUEDA DELANTERA
	5	800096933	1	VITE M20	SCREW M20	VIS M20	SCHRAUBE M20	TORNILLO M20
	6	F000P00259	1	CERCHIO RUOTA ANTERIORE 1,6X21	RIM, FRONT WEHEL 1.6X21	JANTE ROUE AVANT 1,6X21	FELGE, VORDERRAD 1,6X21	LLANTA RUEDA DELANTERA 1,6X21
	7	8A0096930	1	DISTANZIALE	SPACER	ENTRETOISE	ABSTANDHALTER	DISTANCIADOR
	8	8000H1362	36	RAGGIO RUOTA ANTERIORE	SPOKE, FRONT WHEEL	RAYON ROUE AVANT	SPEICHE, VORDERRAD	RADIO RUEDA DELANTERA
	9	8000A6208	36	NIPPLO RAGGIO	NIPPLE, SPOKE	ECROU RAYON	NIPPEL, SPEICHE	TUERCA RADIO
	10	F000A00091	1	MOZZO RUOTA ANTERIORE	HUB, FRONT WHEEL	MOYEU ROUE AVANT	RADNABE, VORNE	CUBO RUEDA DELANTERA
	11	F000P00120	1	DISTANZIALE INTERNO CUSCINETTI	SPACER, HUB BEARING	ENTRETOISE INTERNE ROULEMENT	KUGELLAGER INNEREABSTANDHALTER	DISTANCIADOR INTERIOR COJINETE
	12	66N021270	1	ANELLO SEEGER INTERNO 42MM DIN472	CIRCLIP 42MM DIN472	CIRCLIP 42MM DIN472	SEEGERRING 42MM DIN472	ANILLO SEEGER 42MM DIN472
	13	800084938	2	CUSCINETTO A SFERE 25X42X9	BEARING, BALL 25X42X9	ROULEMENT A BILLES 25X42X9	KUGELLAGER 25X42X9	COJINETE DE BOLAS 25X42X9
	14	800022966	1	PARAPOLVERE 32X42X7	SEAL, DUST 32X42X7	PARE POUSSIÈRE 32X42X7	STAUBDECKEL 32X42X7	GUARDAPOLVO 32X42X7
	15	8000H6187	1	PARAOLIO 28X50X5	OIL SEAL 28X50X5	BAGUE D'ETANCHEITE 28X50X5	WELLENDICHRING 28X50X5	RETEN DE ACEITE 28X50X5
	16	800099632	1	DISCO FRENO ANTERIORE	DISC, FRONT BRAKE	DISQUE FREIN AVANT	BREMSSCHEIBE, VORNE	DISCO FRENO DELANTERO

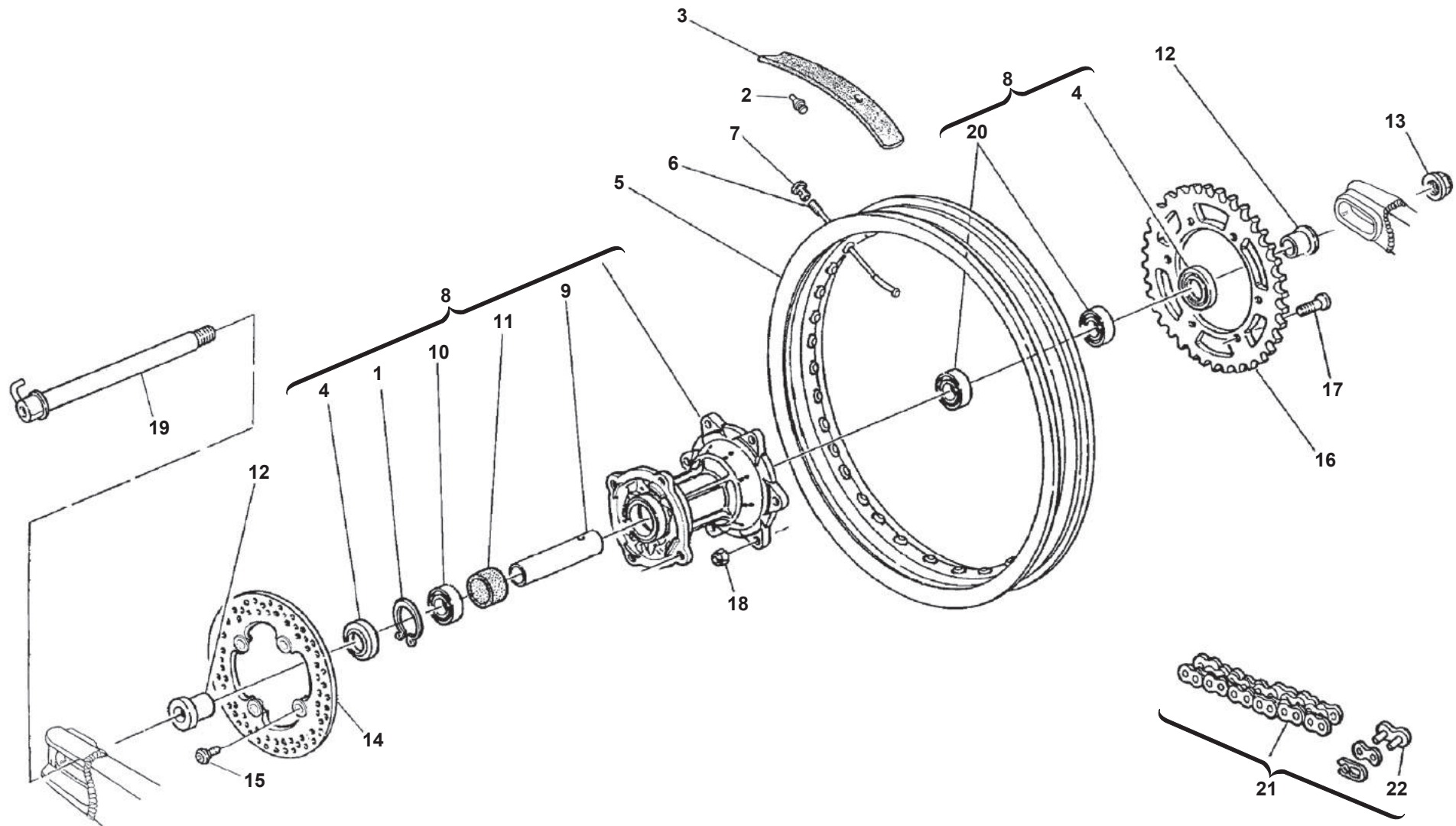



RS-SM 650R/2016

RUOTA POSTERIORE - REAR WHEEL ROUE ARRIERE - HINTERRAD RUEDA TRASERA

TAVOLA
DRAWING
TABLE
BILD
TABLA

28

Note Notes Notas	Pos. No. N. Index Pos.	N. Cod. Code No. Nr. Code Code Nr N. Cod.	Q.tà Q.ty Q.te M.ge C.ad	DENOMINAZIONE	NAME	DESIGNATION	BESHREIBUNG	DENOMINACION
	1	66N021272	1	ANELLO ELASTICO 50,5 MM	CIRCLIP 50.5 MM	CIRCLIP 50,5 MM	SPRENGRING 50,5 MM	ANILLO ELASTICO 50,5 MM
RS 650R	2	800009570	1	TAMPONE IN GOMMA 9,2X8,5X6X15	RUBBER PAD 9.2X8.5X6X15	TAMPON EN CAOUTCHOUC 9,2X8,5X6X15	GUMMISTOPFEN 9,2X8,5X6X15	PUNZON GOMA 9,2X8,5X6X15
SM 650R	3	8B0082879	1	FASCIA SALVACAMERA	PROTECTOR, INNER TUBE	FOND JANTE	FELGENBAND	PROTECTOR CAMARA
RS 650R	3	800001688	1	FASCIA SALVACAMERA	PROTECTOR, INNER TUBE	FOND JANTE	FELGENBAND	PROTECTOR CAMARA
	4	800089572	2	PARAOLIO 32X47X7	OIL SEAL 32X47X7	BAGUE D'ETANCHEITE 32X47X7	WELLENDICHRING 32X47X7	RETEN DE ACEITE 32X47X7
SM 650R	5	F000P00262	1	CERCHIO RUOTA POSTERIORE 4,25X17	RIM, REAR WHEEL 4,25X17	JANTE ROUE ARRIERE 4,25X17"	FELGE, HINTENRAD 4,25X17"	LLANTA RUEDA TRASERA 4,25X17"
RS 650R	5	F000P00260	1	CERCHIO RUOTA POSTERIORE 2,15X18	RIM, REAR WHEEL 2,15X18	JANTE ROUE ARRIERE 2,15X18	FELGE, HINTENRAD 2,15X18	LLANTA RUEDA TRASERA 2,15X18
SM 650R	6	8000H1725	18	RAGGIO RUOTA POSTERIORE LATO DISCO	REAR WHEEL SPOKE, DISC SIDE	RAYON ROUE ARRIERE COTE DISQUE	HINTERRADSPICHE SCHEIBE SEITE	RADIO RUEDA TRASERA LATO DISCO
SM 650R	6	8000H1726	18	RAGGIO RUOTA POSTERIORE LATO CORONA	REAR WHEEL SPOKE, SPROCKET SIDE	RAYON ROUE ARRIERE COTE COURONNE	HINTERRADSPICHE ZAHNKETTENRAD SEITE	RADIO RUEDA TRASERA LATO CORONA
RS 650R	6	8000H1533	18	RAGGIO RUOTA POSTERIORE 194,5 MM	SPOKE, REAR WHEEL 194,5 MM	RAYON ROUE ARRIERE 194,5 MM	SPEICHE, HINTERRAD 194,5 MM	RADIO RUEDA TRASERA 194,5 MM
RS 650R	6	8000H1534	18	RAGGIO RUOTA POSTERIORE LATO CORONA	REAR WHEEL SPOKE, SPROCKET SIDE	RAYON ROUE ARRIERE COTE COURONNE	HINTERRADSPICHE ZAHNKETTENRAD SEITE	RADIO RUEDA TRASERA LATO CORONA
SM 650R	7	69N429005	36	NIPPLO RAGGIO	NIPPLE, SPOKE	ECROU RAYON	NIPPEL, SPEICHE	TUERCA RADIO
RS 650R	7	8000A6209	36	NIPPLO RAGGIO ALPINA	NIPPLE, SPOKE ALPINA	ECROU RAYON ALPINA	NIPPEL, SPEICHE ALPINA	TUERCA RADIO ALPINA
	8	F000A00093	1	MOZZO RUOTA POSTERIORE	HUB, REAR WHEEL	MOYEU ROUE ARRIERE	RADNABE, HINTEN	CUBO RUEDA TRASERA
RS 650R	9	800092414	1	DISTANZIALE INTERNO CUSCINETTI	SPACER, HUB BEARING	ENTRETOISE INTERNE ROULEMENT	KUGELLAGER INNEREABSTANDHALTER	DISTANCIADOR INTERIOR COJINETE
	10	8B0026846	1	CUSCINETTO A SFERE 25X47X16	BEARING, BALL 25X47X16	ROULEMENT A BILLES 25X47X16	KUGELLAGER 25X47X16	COJINETE DE BOLAS 25X47X16
	11	F000P00121	1	DISTANZIALE	SPACER	ENTRETOISE	ABSTANDHALTER	DISTANCIADOR
	12	800096938	2	DISTANZIALE ESTERNO	SPACER, OUTER	ENTRETOISE EXTERIEUR	ABSTANDHALTER, AUSSER	DISTANCIADOR EXTERIOR
	13	Y00093072	1	DADO M20X1,5 CH27	NUT M20X1.5 CH27	ECROU M20X1,5 CH27	MUTTER M20X1,5 CH27	TUERCA M20X1,5 CH27
	14	800088887	1	DISCO FRENO POSTERIORE	DISC REAR BRAKE	DISQUE FREIN ARRIERE	BREMSSCHEIBE, HINTEN	DISCO FRENO TRASERO
	15	800055878	4	VITE TPEI M6X1X11	SCREW TPEI M6X1.00X11	VIS TPEI M6X1,00X11	SCHRAUBE TPEI M6X1,00X11	TORNILLO TPEI M6X1,00X11
SM 650R	16	8H00A4859	1	CORONA Z38	REAR SPROCKET T38	COURONNE D38	ZAHNKETTENRAD Z38	CORONA D38
RS 650R	16	8000A4859	1	CORONA Z42	REAR SPROCKET T42	COURRONE D42	ZAHNKETTENRAD Z42	CORONA D42
	17	8000H0158	6	VITE SPECIALE TSEI M8X1,25X28 CH6	SCREW, SPECIAL TSEI M8X1.25X28 CH6	VIS SPECIAL TSEI M8X1,25X28 CH6	SPEZIALSCHRAUBE TSEI M8X1,25X28 CH6	TORNILLO ESPECIAL TSEI M8X1,25X28 CH6
	18	Y00043928	6	DADO	NUT	ECROU	MUTTER	TUERCA
	19	F000P00066	1	PERNO RUOTA POSTERIORE	AXLE, REAR WHEEL	AXE ROUE ARRIERE	HINTERRADACHSE	EJE RUEDA TRASERA
	20	8A0026846	2	CUSCINETTO A SFERE 6005	BEARING, BALL 6005	ROULEMENT A BILLES 6005	KUGELLAGER 6005	COJINETE DE BOLAS 6005
SM 650R	21	8D00A6261	1	CATENA DID 5/8X6,5-110	CHAIN DID 5/8X6.5-110	CHAINE DID 5/8X6,5-110	KETTE DID 5/8X6,5-110	CADENA DID 5/8X6,5-110
RS 650R	21	8000A6261	1	CATENA DID 5/8X6,5-112	CHAIN DID 5/8X6.5-112	CHAINE DID 5/8X6,5-112	KETTE DID 5/8X6,5-112	CADENA DID 5/8X6,5-112
	22	800079789	1	GIUNTO CATENA DID 520V6	CHAIN LINK DID 520V6	JOINT CHAINE DID 520V6	VERBINDUNG KETTE DID 520V6	RACORD CADENA DID 520V6

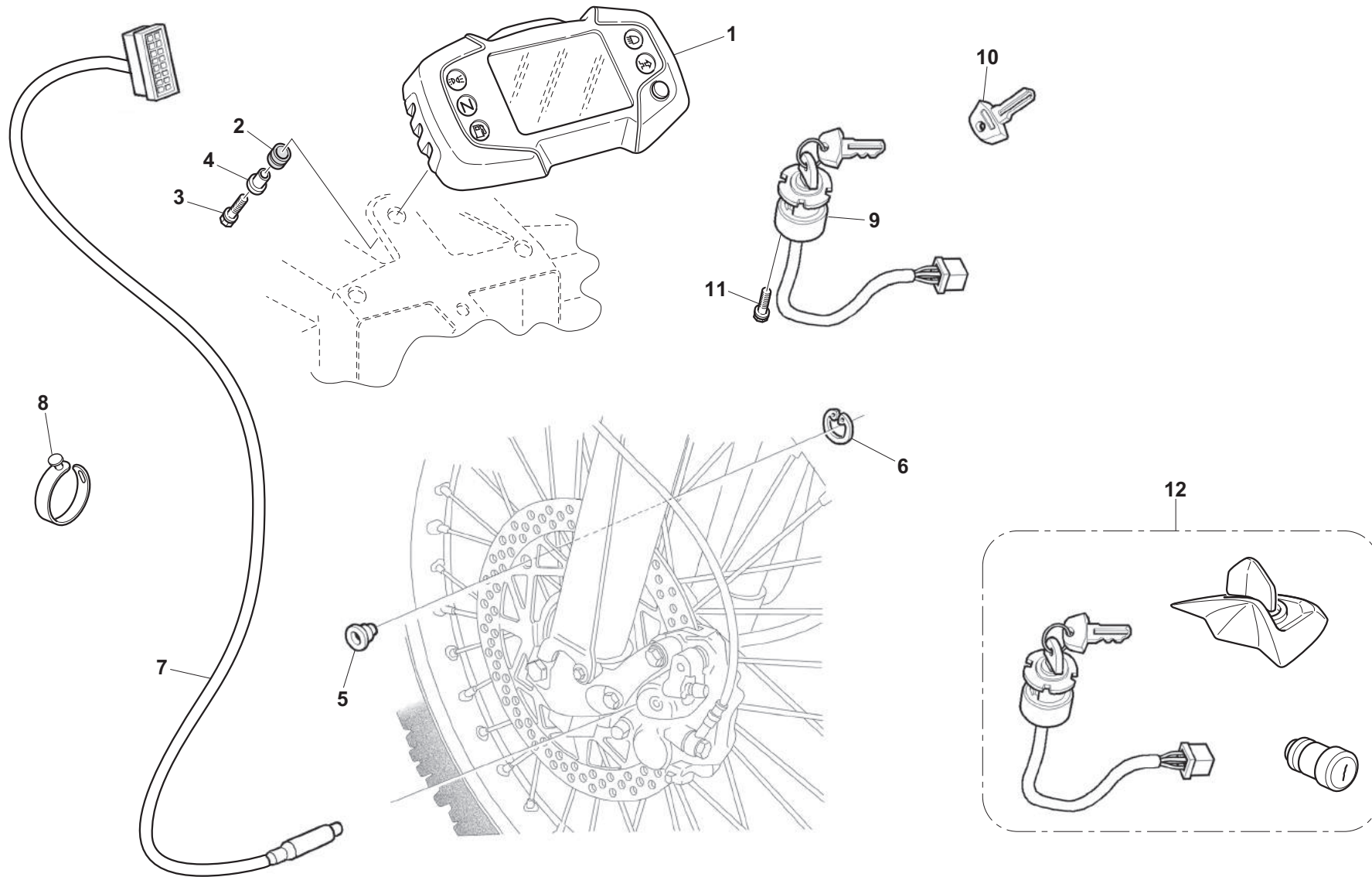

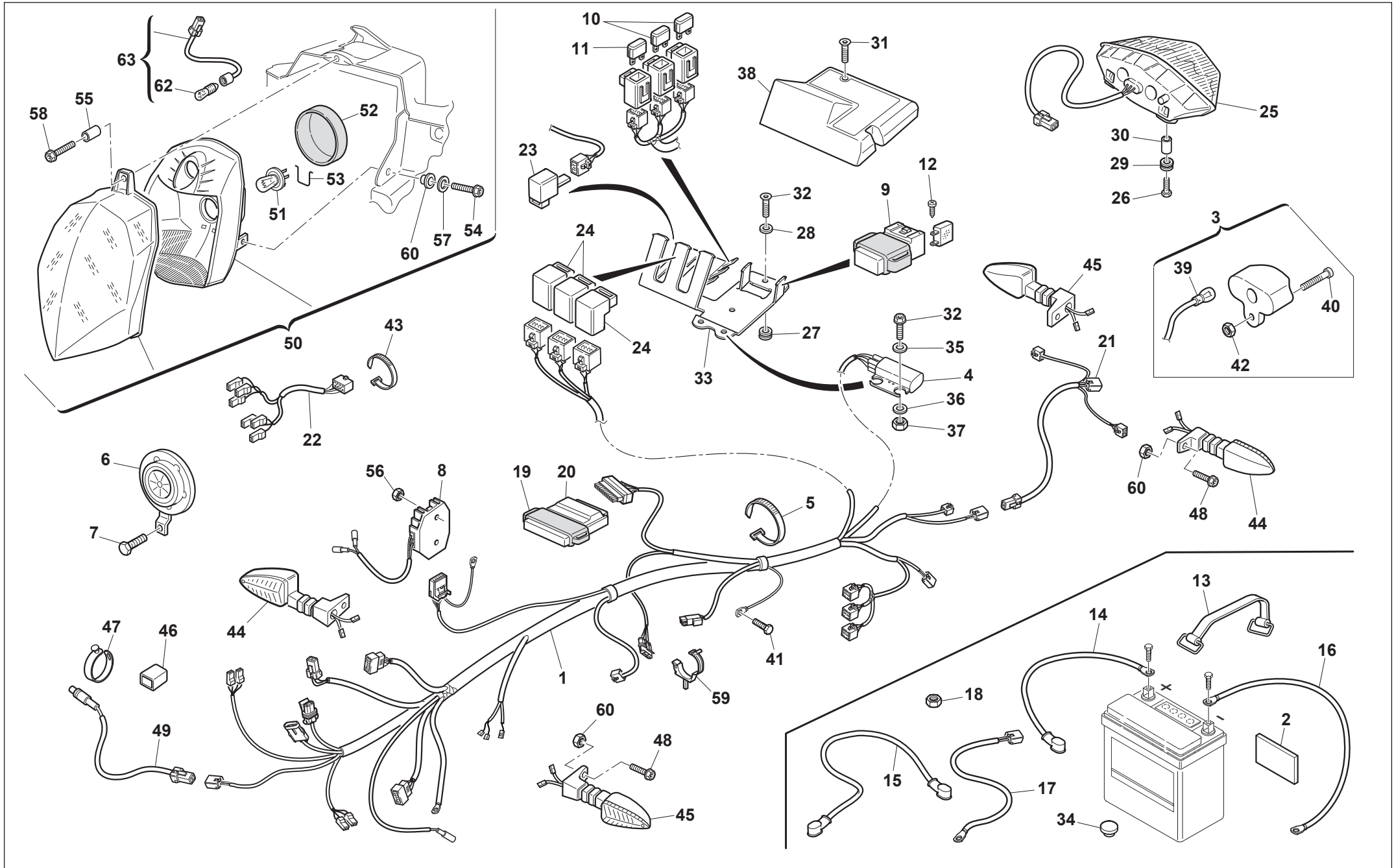

**RS-SM 650R/2016**

**GRUPPO CAVI, PARTI ELETTRICHE - MAIN WIRING HARNESS, ELECTRICAL PARTS -
CABLES PRINCIPAL, PARTIES ELECTRIQUES - KABEL, ELEKTRISCHE KOMPONENTE -
GRUPO PRINCIPAL CABLES, PARTES ELECTRICAS**

TAVOLA
DRAWING
TABLE
BILD
TABLA

30

Note Notes Notes Marke Notas	Pos. No. N. Index Pos.	N. Cod. Code No. Nr. Code Code Nr N. Cod.	Q.tà Q.ty Q.te M.ge C.ad	DENOMINAZIONE	NAME	DESIGNATION	BESHREIBUNG	DENOMINACION
	1	E000P0049	1	IMPIANTO ELETTRICO	WIRING HARNESS	FAISCEAU CABLES PRINCIPAL	HAUPTVERKABELUNG	GRUPO CABLES PRINCIPAL
	2	800057673	1	SPESSORE ELASTICO	CUSHION	SILENTBLOC	PUFFER	CASQUILLO ELASTICO
	3	8000A0212	1	FANALE ILLUMINAZIONE TARGA	LAMP, LICENSE PLATE	FEU ECLARAGE PLAQUE IMMATRICULATION	KENNZEICHENLEUCHE	FARO LUZ MATRICULA
	4	8000A6756	1	SENSORE DI CADUTA	SENSOR, LEAN ANGLE	CAPTEUR SECURITE CHUTE	NEIGUNG ABTASTER	SENSOR INCLINACION
	5	800056444	15	FASCETTA 188 MM	CLAMP 188 MM	COLLIER 188 MM	SHELLE 188 MM	ABRAZADERA 188 MM
	6	E000A00026	1	AVVISATORE ACUSTICO	HORN	AVERTISSEUR SONORE	HUPE	BOCINA
	7	Z00062725	1	VITE TEF M6X1,00X10 CH8	SCREW TEF M6X1.00X10 CH8	VIS TEF M6X1,00X10 CH8	SCHRAUBE TEF M6X1,00X10 CH8	TORNILLO TEF M6X1,00X10 CH8
	8	8000A6768	1	REGOLATORE DI TENSIONE	REGULATOR & RECTIFIER	REGULATEUR TENSION	SPANNUNGSREGLER	REGULADOR TENSION
	9	8000H0809	1	TELERUTTORE AVVIAMENTO	RELAY, STARTING MOTOR	RELAIS DEMARRAGE	STARTRELAIS	RELE ARRANQUE
	10	8F0095647	2	FUSIBILE 15A	FUSE 15A	FUSIBLE 15A	SICHERUNG 15A	FUSIBLE 15A
	11	8G0095647	1	FUSIBILE 20A	FUSE 20A	FUSIBLE 20A	SICHERUNG 20A	FUSIBLE 20A
	12	ZS0067545	3	VITE TEF M6X1 CH8	SCREW TEF M6X1 CH8	VIS TEF M6X1 CH8	SCHRAUBE TEF M6X1 CH8	TORNILLO TEF M6X1 CH8
	13	800077612	1	CINGHIA BATTERIA	BAND, BATTERY	SANGLE BATTERIE	GURTEL, BATTERIE	CORREA BATERIA
	14	8000H1868	1	CAVO POLO POSITIVO	WIRE, BATTERY PLUS LEAD	CABLE POSITIF	PLUSPOLKABEL	CABLE POSITIVO
	15	8000H1869	1	CAVO MOTORINO AVVIAMENTO	WIRE STARTER MOTOR	CORDON MOTEUR DEMARRAGE	VERKABELUNG STARTERMOTOR	CABLEADO MOTOR ARRANQUE
	16	8000H1871	1	CAVETTO DI MASSA	GROUND CABLE	CABLE MASSE	MASSE KABEL	CABLE MASA
	17	8000H1870	1	CAVO MASSA BATTERIA	BATTERY GROUNDING CABLE	CABLE MASSE BATTERIE	BATTERIEMASSEKABEL	CABLE TIERRA BATERIA
	18	Z00061313	1	DADO M6X1 H6 CH10	NUT M6X1 H6 CH10	ECROU M6X1 H6 CH10	MUTTER M6X1 H6 CH10	TUERCA M6X1 H6 CH10
	19	F000P00132	1	SUPPORTO CENTRALINA INIEZIONE	BRACKET ENGINE CONTROL UNIT	SUPPORT UNITE' CONTROLE INJECTION	HALTER, EINSPRITZUNG ZENTRALANLAGE	SOPORTE CENTRAL INYECCION
	20	E000P00738	1	CENTRALINA INIEZIONE	ENGINE CONTROL UNIT	CENTRALE INJECTION	EINSPRITZUNG ZENTRALANLAGE	CENTRAL INYECCION
	21	8000H1176	1	CAVO FANALE POSTERIORE	CABLE, TAILLIGHT	CABLE FEU ARRIERE	KABELBAUM SCHLUSSLICHT	CABLE FARO PILOTO
	22	8000A6094	1	CAVO FANALE ANTERIORE	CORD, HEADLIGHT	CABLE FEU AVANT	VERKABELUNG SCHEINWERFER	CABLE FARO DELANTERO
	23	8000H1082	1	INTERMITTENZA LAMPEGGIATORI	FLASHER RELAY	RELAIS CLIGNOTANTS	BLINKERRELAIS	RELE INTERMITENTES
	24	8000A6749	3	RELE'	RELAY	RELAIS	RELAIS	RELE
	25	8000H1418	1	FANALE POSTERIORE	TAIL LIGHT	FEU ARRIERE	SCHLUSSLICHT	LUZ COLA
	26	Z00062727	2	VITE TE M6X1X16 CH8	SCREW TE M6X1X16 CH8	VIS TE M6X1X16 CH8	SCHRAUBE TE M6X1X16 CH8	TORNILLO TE M6X1X16 CH8
	27	8000H2374	3	SILENTBLOCK	DAMPER	SILENTBLOC	SCHWINGUNGSDAEMPFER	CASQUILLO ELASTICO
	28	800067245	3	DISTANZIALE	SPACER	ENTRETOISE	ABSTANDHALTER	DISTANCIADOR
	29	800095128	2	GOMMINO	GROMMET	CAOUTCHOUC	GUMMITEILE	GOMA
	30	8000H1735	2	BOCCOLA FLANGIATA	BUSH WITH COLLAR	DOUILLE BRIDEE	GEFLANSCHBUCHSE	CASQUILLO REBORDEADO
	31	Z00065535	3	VITE TCEI M5X0,8X14	SCREW	VIS	SCHRAUBE	TORNILLO
	32	60ND01030	2	VITE TE M4X0,7X25	SCREW TE M4X0.7X25	VIS TE M4X0,7X25	SCHRAUBE TE M4X0,7X25	TORNILLO TE M4X0,7X25
	33	8000H1813	1	SUPPORTO CONNETTORI	BRACKET, CONNECTOR	SUPPORT CONNECTEUR	KONSOLE VERBINDER	SOPORTE CONECTOR

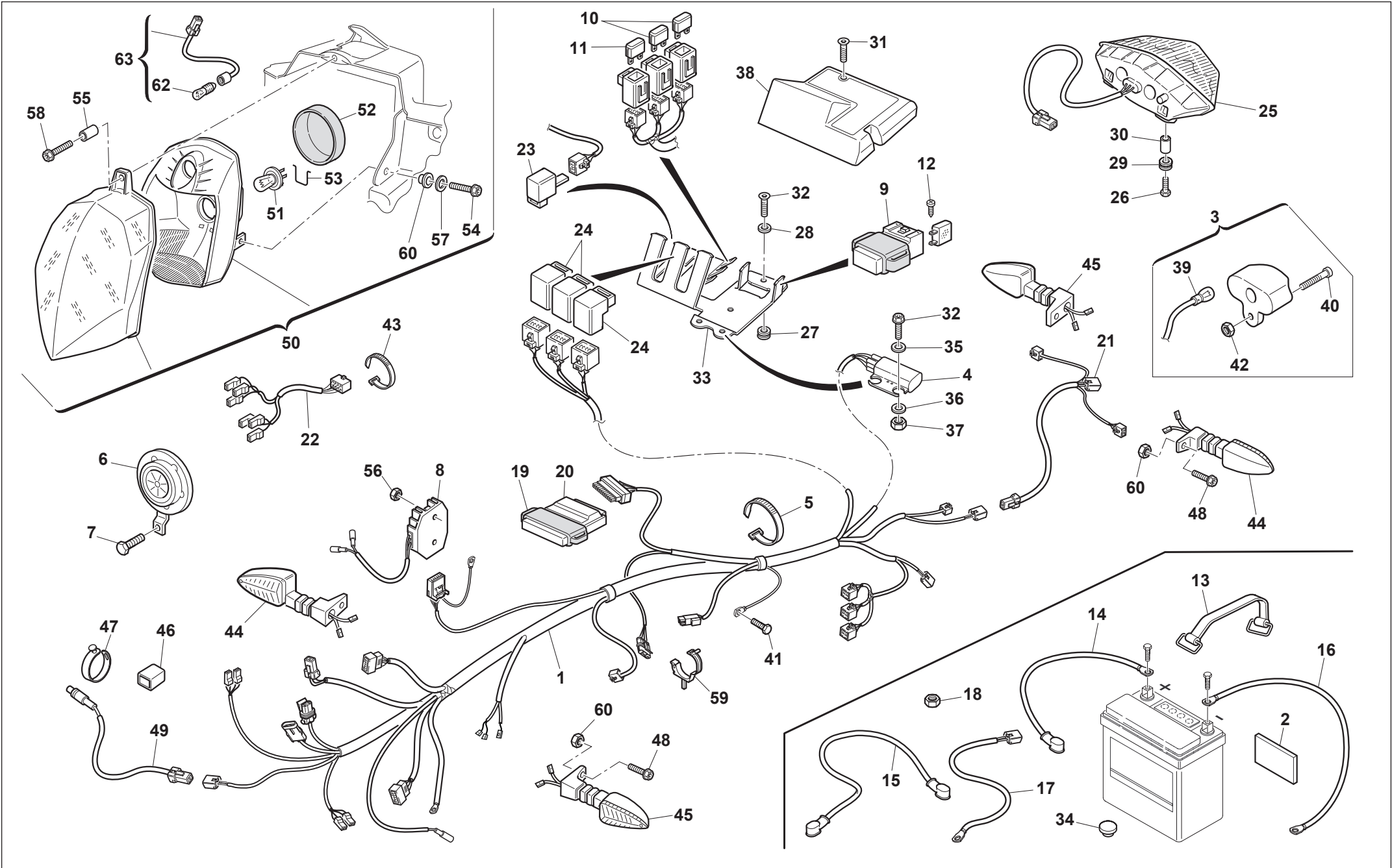



RS-SM 650R/2016

GRUPPO CAVI, PARTI ELETTRICHE - MAIN WIRING HARNESS, ELECTRICAL PARTS - CABLES PRINCIPAL, PARTIES ELECTRIQUES - KABEL, ELEKTRISCHE KOMPONENTE - GRUPO PRINCIPAL CABLES, PARTES ELECTRICAS

TAVOLA
DRAWING
TABLE
BILD
TABLA

30

Note Notes Marke Notas	Pos. No. N. Index Pos.	N. Cod. Code No. Nr. Code Code Nr N. Cod.	Q.tà Q.ty Q.te M.ge C.ad	DENOMINAZIONE	NAME	DESIGNATION	BESHREIBUNG	DENOMINACION
	34	800045490	3	GOMMINO	GROMMET	CAOUTCHOUC	GUMMITEILE	GOMA
	35	Z00038291	2	RONDELLA 4,2X10,8X1,2	WASHER 4.2X10.8X1.2	RONDELLE 4,2X10,8X1,2	SCHEIBE 4,2X10,8X1,2	ARANDELA 4,2X10,8X1,2
	36	62ND15547	2	RONDELLA	WASHER 12X4.3X0.8	RONDELLE 12X4,3X0,8	SCHEIBE 12X4,3X0,8	ARANDELA 12X4,3X0,8
	37	Z00091033	2	DADO AUTOBLOCCANTE M4	NUT, SELF-LOCKING M4	ECROU AUTOBLOQUANT M4	SELBSTSPERRENDE MUTTER M4	TUERCA AUTOBLOQUEANTE M4
	38	8000H2106	1	COPERCHIO	COVER	COUVERCLE	DECKEL	CUBIERTA
	39	800036230	1	LAMPADINA 12V 5W T10	WEDGE BASE BULB 12V5W T10	AMPOULE 12V 5W T10	GLUEHLAMPE 12V 5W T10	LAMPARA 12V 5W T10
	40	60ND07330	1	VITE TCEI M5X0,8X16	SCREW TCEI M5X0.8X16	VIS TCEI M5X0,8X16	SCHRAUBE TCEI M5X0,8X16	TORNILLO TCEI M5X0,8X16
	41	Z00067997	1	VITE TEF M5X0,8X12	SCREW TEF M5X0.8X12	VIS TEF M5X0,8X12	SCHRAUBE TEF M5X0,8X12	TORNILLO TEF M5X0,8X12
	42	61ND15192	1	DADO	NUT	ECROU	MUTTER	TUERCA
	43	80A050005	1	FASCETTA	CLAMP	COLLIER	KLAMMER	ABRAZADERA
	44	E000P00263	2	LAMPEGGIATORE ANT.DX/POST.SX	FLASHER LIGHT FRONT RH - REAR LH	CLIGNOTANT AVANT DROIT-ARRIERE GAUCHE	BLINKER, VORDER RECHTS RUECK LINKS	INTERMITENTE DEL.DERECHO-TRASERO IZQ.
	45	EA00P00263	2	LAMPEGGIATORE ANT.SX/POST.DX	FLASHER LIGHT FRONT LH - REAR RH	CLIGNOTANT AVANT GAUCHE-ARRIERE DROIT	BLINKER, VORDER LINKS RUECK RECHTS	INTERMITENTE DEL.IZQUER-TRASERO DERECHO
	46	8000A6790	1	TAPPO CONNETTORE DIAGNOSI	PLUG CONNECTOR DIAGNOSTIC	BOUCHON CONNECTEUR DIAGNOSTIC	VERSCHLUSS DIAGNOSE STECKER	TAPON CONECTOR DIAGNOSIS
	47	800071578	4	FASCETTA 78 MM	CLAMP 78 MM	COLLIER 78 MM	SHELLE 78 MM	ABRAZADERA 78 MM
	48	Z00062727	4	VITE TE M6X1X16 CH8	SCREW TE M6X1X16 CH8	VIS TE M6X1X16 CH8	SCHRAUBE TE M6X1X16 CH8	TORNILLO TE M6X1X16 CH8
	49	800075477	1	CAVO INTERRUOTORE STOP	CABLE, STOP SWITCH	CABLAGE INTERRUPTEUR STOP	VERKABELUNG BREMSCHALTER	CABLEADO INTERRUPTOR LUZ FRENO
	50	8000H1177	1	FANALE ANTERIORE	HEAD LIGHT	FEU AVANT	SCHEINWERFER	FARO DELANTERO
	51	800042946	1	LAMPADINA 12V 55/60W ALOGENA H4	BULB 12V 55/60W HALOGEN H4	AMPOULE 12V 55/60W HALOGENE H4	GLUEHLAMPE 12V 55/60W HALOGEN H4	LAMPARA 12V 55/60W HALOGENA H4
	52	8000H1874	1	CAPPUCCIO PORTALAMPADA	COVER, SOCKET	CAPUCHON, PORTE AMPOULE	KAPPE, LAMPENFASSUNG	CAPUCHON PORTA-LAMPARA
	53	8000H1873	1	MOLLA	SPRING	RESSORT	FEDER	MUELLE
	54	Z00062727	2	VITE TE M6X1X16 CH8	SCREW TE M6X1X16 CH8	VIS TE M6X1X16 CH8	SCHRAUBE TE M6X1X16 CH8	TORNILLO TE M6X1X16 CH8
	55	8A00A1051	1	DISTANZIALE	SPACER	ENTRETOISE	ABSTANDHALTER	DISTANCIADOR
	56	Z00044240	2	DADO AUTOBLOCCANTE M6X1 CH10	NUT, SELF LOCKING M6X1 CH10	ECROU AUTOBLOQUANT M6X1 CH10	SELBSTSPERRENDE MUTTER M6X1 CH10	TUERCA AUTOBLOQUEANTE M6X1 CH10
	57	62ND15645	2	RONDELLA	WASHER	RONDELLE	SCHEIBE	ARANDELA
	58	ZB0067997	1	VITE TEF M5X0,8X30 CH8	SCREW TEF M5X0.8X30 CH8	VIS TEF M5X0,8X30 CH8	SCHRAUBE TEF M5X0,8X30 CH8	TORNILLO TEF M5X0,8X30 CH8
	59	8A0060283	1	PASSACAVO	GUIDE, CABLE	PASSE-CABLE	KABELDURCHGANG	PASACABLES
	60	Z00044240	2	DADO AUTOBLOCCANTE M6X1 CH10	NUT, SELF LOCKING M6X1 CH10	ECROU AUTOBLOQUANT M6X1 CH10	SELBSTSPERRENDE MUTTER M6X1 CH10	TUERCA AUTOBLOQUEANTE M6X1 CH10
	61	8000H3681	2	BUSSOLA	BUSH	DOUILLE	BUCHSE	BUJE
	62	800036230	1	LAMPADINA 12V 5W T10	WEDGE BASE BULB 12V5W T10	AMPOULE 12V 5W T10	GLUEHLAMPE 12V 5W T10	LAMPARA 12V 5W T10
	63	800095886	1	PORTALAMPADA POSIZIONE	SOCKET, PILOT LIGHT	PORTE AMPOULE, LAMPE-TEMOIN	FASSUNG, KONTROLLAMPE	PORTA-LAMPARA

INFORMAZIONI IMPORTANTI

Pressione pneumatici a freddo

Solo guidatore	ANT.	Kg./cm ²	psi
	POST.	Kg./cm ²	psi
Guidat. e passegg.	ANT.	Kg./cm ²	psi
	POST.	Kg./cm ²	psi

REGOLAZIONE CATENA

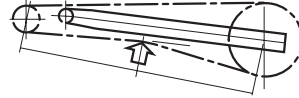

4

3

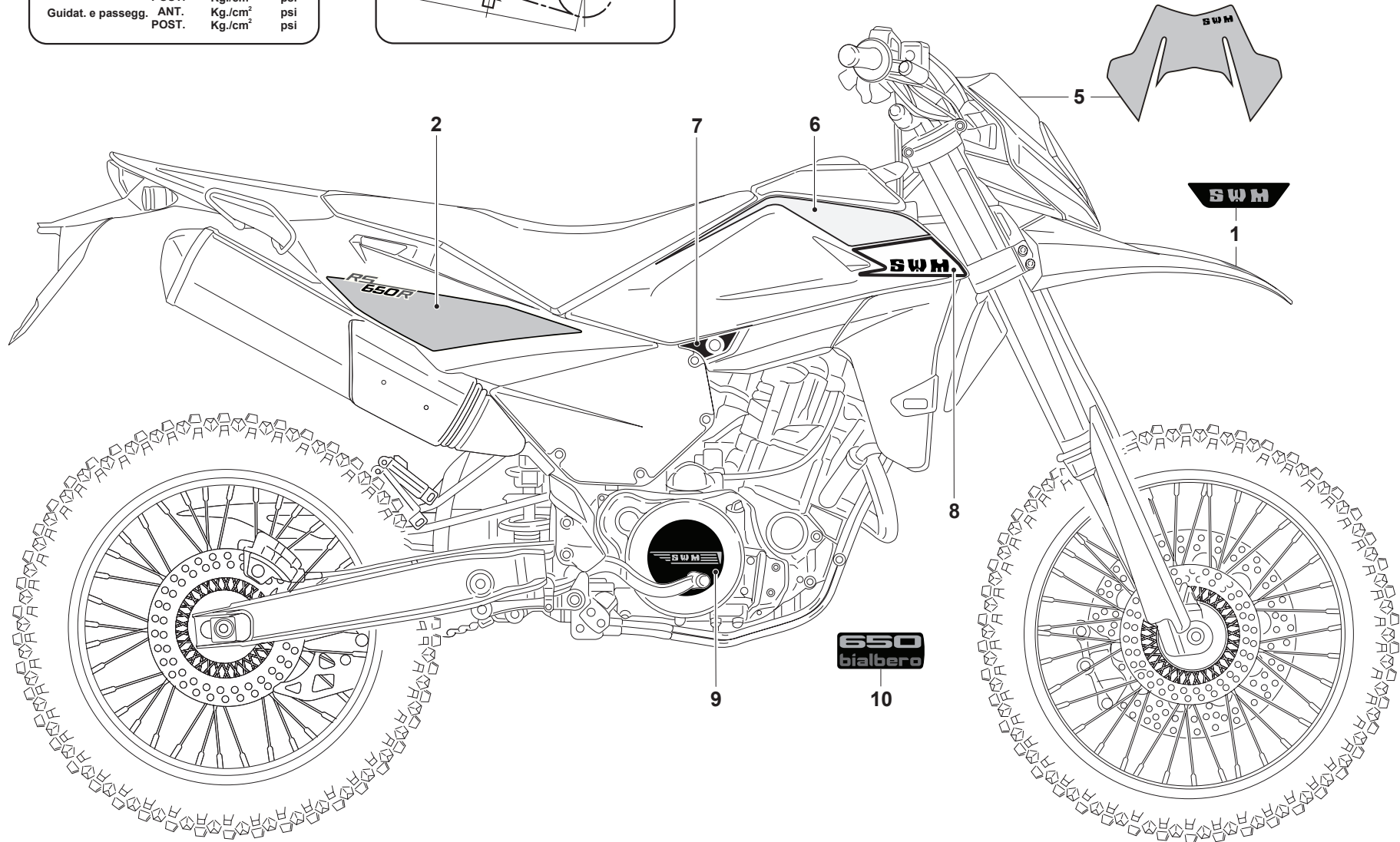

4

INFORMAZIONI IMPORTANTI
Pressione pneumatici a freddo

Solo guidatore	ANT.	Kg./cm ²	psi
	POST.	Kg./cm ²	psi
Guidat. e passegg.	ANT.	Kg./cm ²	psi
	POST.	Kg./cm ²	psi

